

SELECTION OF THE THERMAL ELECTRICAL GENERATOR

Product Family: **EM8900**

Part Number: EM8900

Keywords: Harvesting, Thermal Electrical Generator, TEG, Transformer

ABSTRACT

The EM8900 is an inductive ultra-low voltage DCDC converter optimized for Thermal Electrical Generator (TEG). This document describes how to properly select a TEG, an inductive element and capacitors.

ABBREVIATIONS

HRV	Harvester, main source of energy (solar or TEG)
TEG	Thermal Electrical Generator
ZT	Figure of merit of the TEG
R_{TH}	Thermal resistivity of the TEG [KW]
R_{COOLER}	Thermal resistivity of the cooler [KW]
R_{TEG}	Electrical resistivity of the TEG [Ω]
α	Seebeck coefficient [V/K]
V_{OV}	TEG open voltage [V]
R_{IN}	Input impedance of the DCDC converter [Ω]
P_{IN}	Input power of the DCDC converter [W]
P_{OUT}	Output power of the DCDC converter [W]
η	DCDC converter efficiency [-]
ΔT_{TEG}	Delta of temperature over the TEG [K]
ΔT_{GLOBAL}	Delta of temperature from the hot source to the cold source [K]
C_{FB}	Feed-back capacitor between the secondary side of transformer to the EM8900
C_{AC}	AC energy coupling capacitor between the secondary side of transformer to the EM8900
C_{DCDC}	Decoupling capacitor on the output VSUP of the EM8900
C_{HRV}	Decoupling capacitor connected in parallel to the TEG

1. SCOPE

The EM8900 is an ultra-low voltage DCDC converter optimized for TEG harvester. This document describes how to select the TEG and all external components, namely the transformer and all capacitors.

2. BLOCK DIAGRAM

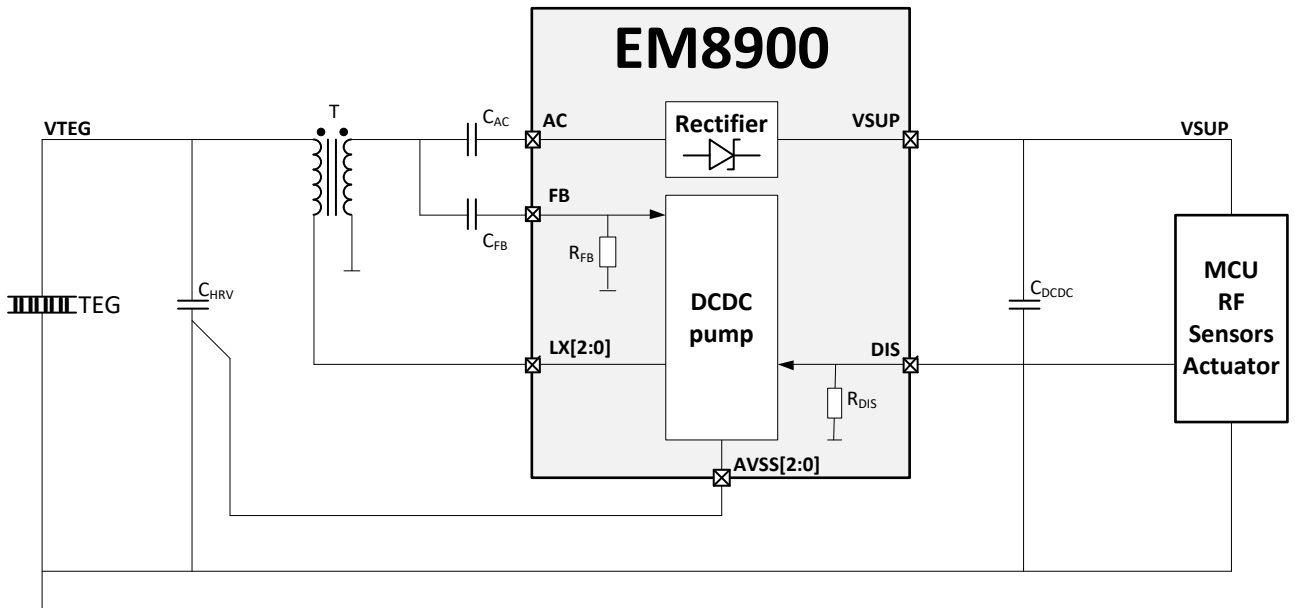

Figure 2-1: Block Diagram

3. TEG AND EXTERNAL COMPONENTS SELECTION

The following sequence is used to select TEG and the transformer elements:

1. Select the transformer turn ratio and its part number
2. Select the TEG thermal resistivity R_{TH} [K/W]
3. Select the feed-back capacitor C_{FB}
4. Select the TEG electrical resistivity R_{TEG} [Ω]
5. Select the TEG Seebeck coefficient α [V/K] and its part number
6. Select the AC coupling capacitor C_{AC}
7. Select the TEG decoupling capacitor C_{HRV}

3.1 TRANSFORMER TURN RATIO

The following reference transformers are proposed:

Manufacturer	Turn ratio	Size			RDC		Isat primary	Part number	Comments
		Length	Width	Thickness	primary	secondary			
Coilcraft	1:20	6mm	6mm	3.5mm	200m Ω	72 Ω	0.7 A	LPR6235-253PMR	High efficiency at mid-high power level
Coilcraft	1:50	6mm	6mm	3.5mm	85m Ω	200 Ω	0.9 A	LPR6235-123QMR	Compromise between low input voltage and high efficiency at mid power level
Coilcraft	1:100	6mm	6mm	3.5mm	85m Ω	340 Ω	1.6 A	LPR6235-752SMR	Ultra-low input voltage and high efficiency at low power level
Würth Elektronik	1:20	6mm	6mm	4mm	200m Ω	42 Ω	0.7 A	74488540250	High efficiency at mid-high power level
Würth Elektronik	1:50	6mm	6mm	4mm	90m Ω	135 Ω	1.0 A	74488540120	Compromise between low input voltage and high efficiency at mid power level
Würth Elektronik	1:100	6mm	6mm	4mm	85m Ω	205 Ω	1.3 A	74488540070	Ultra-low input voltage and high efficiency at low power level

Table 1 List of Reference Transformers

The turn ratio influences the minimum operating input voltage of the DCDC converter; the higher the turn ratio, the lower the minimum input voltage. But the lower the turn ratio, the higher the efficiency.

3.1.1 Wearable applications

The skin is the hot source of thermal energy. The TEG voltage is very low. Under such conditions the TEG is very small to get a high thermal resistivity (see paragraph 0). The Seebeck coefficient and therefore the DCDC converter input voltage are low.

A turn ratio of 1:100 is preferred for such an application.

3.1.2 Industrial applications

The hot source is strongly connected to the TEG and a cooling element is used to hold the cold side of the TEG at near ambient temperature. Under such conditions the TEG delivers a voltage of few 10mV and a high power level.

A turn ratio of 1:20 is preferred for such application.

If it is necessary to operate at very low delta temperature, a turn ratio of 1:50 can be used, but with an impact on the efficiency.

3.2 THERMAL RESISTIVITY R_{TH}

This is the first parameter to be calculated. It depends on the mechanical aspects of the application; R_{TH} should be equal to the sum of the thermal connections to the hot and cold junctions.

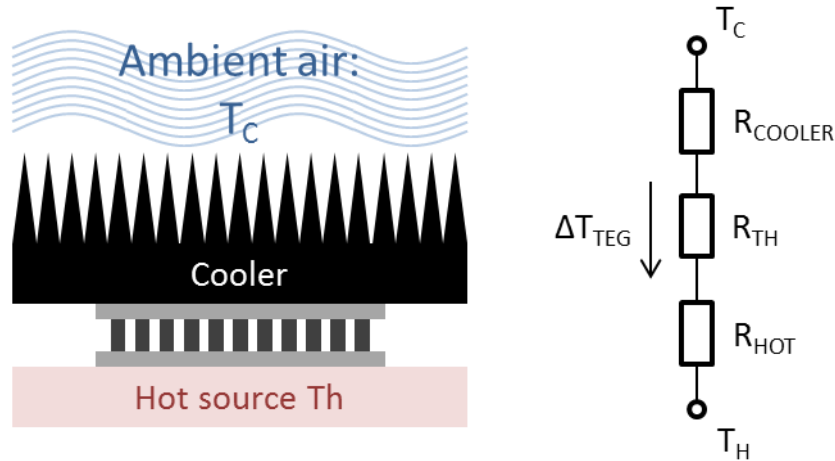

Figure 3-1: Thermal Structure

The maximum thermal power is dissipated when $R_{TH} = R_{COOLER} + R_{HOT}$

If the thermal connection of the TEG to the hot source is strong ($R_{HOT} \ll R_{COOLER}$), $R_{TH} = R_{COOLER}$.

R_{COOLER} depends on the mechanical size of the cooling element, then the TEG resistivity is high for small applications. It could be even larger than 100 [KW] for wearable applications (wristbands or watches).

3.3 FEED-BACK CAPACITOR C_{FB}

The capacitor C_{FB} depends on the DCDC converter output voltage and the transformer turn-ratio as follows:

Maximum output voltage VOUT	Recommended C_{FB} value		
	Transformer turn ratio 1:20	Transformer turn ratio 1:50	Transformer turn ratio 1:100
1.5 V	C_{FB} not required	C_{FB} not required	C_{FB} not required
1.8 V	270 pF	C_{FB} not required	C_{FB} not required
2.4 V	47 pF	100 pF	270 pF
3.0 V	33 pF	47 pF	100 pF
3.6 V	22 pF	33 pF	47 pF
4.2 V	18 pF	22 pF	33 pF

Table 2: C_{FB} Capacitor Selection

3.4 ELECTRICAL RESISTIVITY R_{TEG}

The electrical resistivity has to be matched with the DCDC converter input impedance. This impedance depends on three criteria:

1. The DCDC converter operating power
2. The transformer turn ratio
3. The value of C_{FB}

The following charts is used to determine the best TEG resistivity:

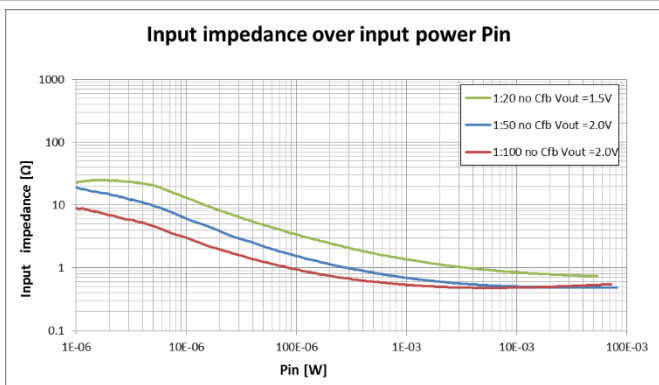

Figure 3-2 Input Impedance vs Power No C_{FB}

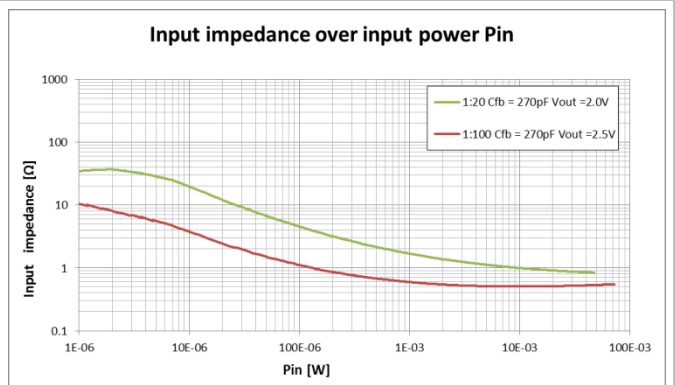

Figure 3-3 Input Impedance vs Power C_{FB} 270 pF

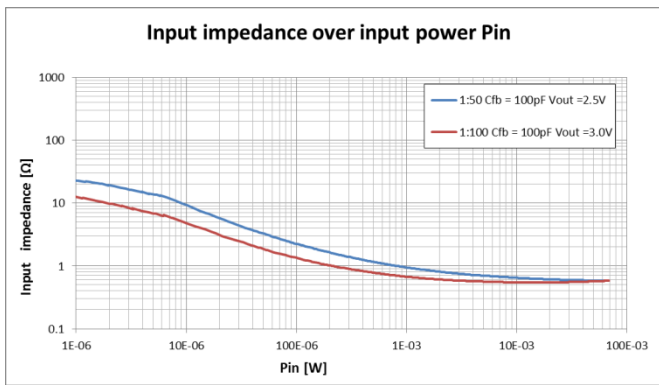

Figure 3-4 Input Impedance vs Power C_{FB} 100 pF

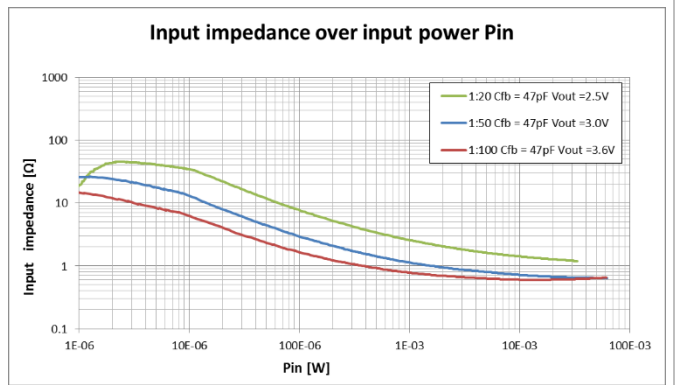

Figure 3-5 Input Impedance vs Power C_{FB} 47 pF

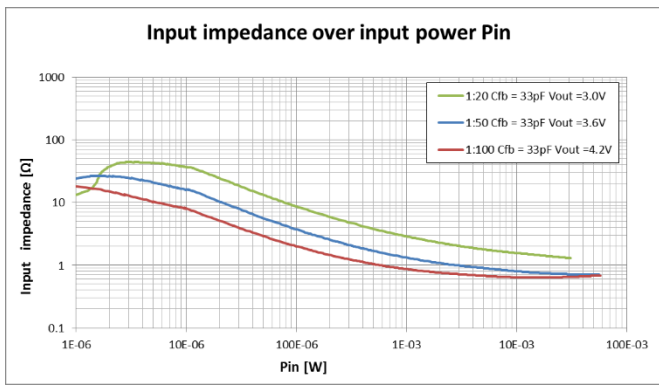

Figure 3-6 Input Impedance vs Power C_{FB} 33 pF

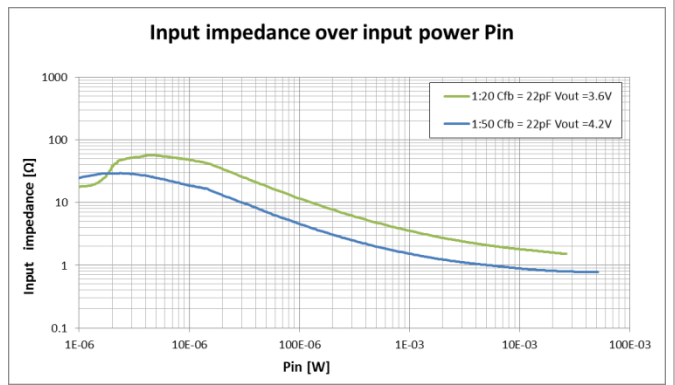

Figure 3-7 Input Impedance vs Power C_{FB} 22 pF

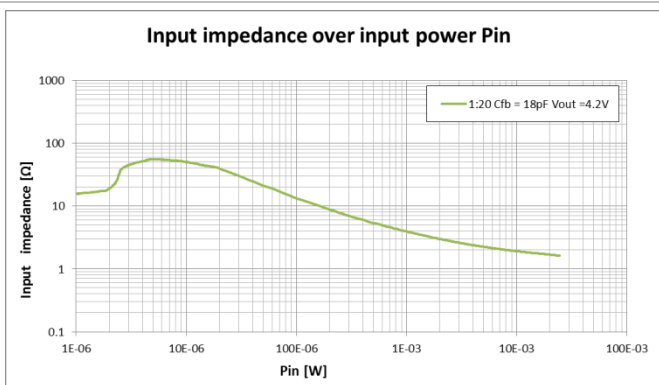

Figure 3-8 Input Impedance vs Power C_{FB} 18 pF

3.5 SEEBECK COEFFICIENT

When the thermal resistivity R_{TH} and the electrical resistivity R_{TEG} are known, the Seebeck coefficient α is computed using Equation 1.

3.5.1 Figure of merit

The figure of merit ZT of a TEG defines its capability to generate an electrical power based on three parameters:

- The thermal resistivity R_{TH} [K/W]
- The electrical resistivity R_{TEG} [Ω]
- The Seebeck coefficient α [V/K]

$$ZT = \frac{\alpha^2 \cdot T \cdot R_{TH}}{R_{TEG}}$$

Equation 1 : Figure of merit of a TEG

T is the average temperature between the hot and the cold junction of the TEG in [K]

ZT depends on the material used. A TEG is selected based on thermal resistivity and the electrical resistivity for a particular application. The Seebeck coefficient depends only on the quality of the material used for the TEG.

Manufacturer	Part number	R_{TH} [K/W]	R_{TEG} [Ω]	α [mV/K]	P_{MAX} [μ W] @ $\Delta T_{TEG} = 5^\circ\text{C}$	ZT [-] @ 25°C
RMT	1MD02-004-04	746	0.76	1.68	23	0.821
RMT	1MD02-004-03	599	0.64	1.68	28	0.783
RMT	1MD02-024-05	155	5.71	10.06	111	0.821
RMT	1MD02-024-04	122	4.59	10.06	138	0.802
RMT	1MC04-017-10	113	2	7	153	0.831
RMT	1MD02-024-03	98	3.86	10.06	164	0.766
RMT	1MD02-040-04/1	73	7.65	16.77	230	0.802
RMT	1MD02-040-03/1	60	6.4	16.77	275	0.784
RMT	1MD02-035-03	49	5.34	15	263	0.616
RMT	1MD03-035-04	30	3.2	15	439	0.620
Marlow	NL1010T-01AC	191	0.64	2.67	70	0.636
Marlow	NL1011T-01AC	77	1.59	6.66	174	0.636
Marlow	NL1021T-01AC	48	0.83	6.33	302	0.684
Marlow	NL1012T-01AC	41	2.95	12.33	322	0.636
Marlow	NL1015T-01AC	33	3.67	15.33	400	0.636
Marlow	NL1022T-01AC	26	1.53	11.66	555	0.684
Marlow	CM35-1.9-01AC	23	1.69	13.99	724	0.806
Marlow	NL1023T-01AC	11.3	3.5	26.65	1268	0.684
Marlow	PL020-4-30-01LS	5.19	1.65	27.32	2827	0.701
Marlow	PL036-4-30-01LS	3.11	3.1	48.98	4837	0.718
Ferrotec	9501/017/030B	27	0.58	7.71	641	0.839
Ferrotec	9501/023/030B	20	0.81	10.73	888	0.839
Ferrotec	9501/031/030B	14.7	1.09	14.42	1192	0.839
Ferrotec	9501/031/040B	11	0.82	14.42	1585	0.839
Ferrotec	9500/031/060B	7.36	0.54	14.42	2407	0.839
Ferrotec	9501/063/040B	5.46	1.65	29.18	3225	0.839

Table 3: List of TEG

3.6 AC COUPLING CAPACITOR C_{AC}

The capacitor C_{AC} couples the AC part of the signal on the secondary side of the DCDC to the rectifier. A bigger value capacitor is best, especially in high power range. 2.2 μF covers the complete power range, 1 μF is sufficient for a maximum power of 100 μW .

3.7 INPUT CAPACITOR C_{HRV}

The capacitor C_{HRV} acts as a charge bank and reduces the input voltage ripple and therefore ohmic loss in the TEG. The size of that capacitor depends on the current amplitude on the transformer primary side, the input voltage average and the internal resistivity of the TEG (R_{TEG}). The higher the current, the higher the C_{HRV} needs to be for a given V_{TEG} and R_{TEG} . C_{HRV} values should be selected as follows:

Input Power range	Recommended C_{HRV} value
Up to 100 μW	47 μF
100 μW to 1 mW	100 μF
Above 1 mW	470 μF

Table 4 C_{HRV} Capacitor Selection

4. PERFORMACNE CALCULATIONS

4.1 INPUT POWER CALCULATION

The DCDC converter efficiency η varies over the output power it has to deliver. The following figures show efficiency of the DCDC over output power and thus allow TEG power calculations for the particular application.

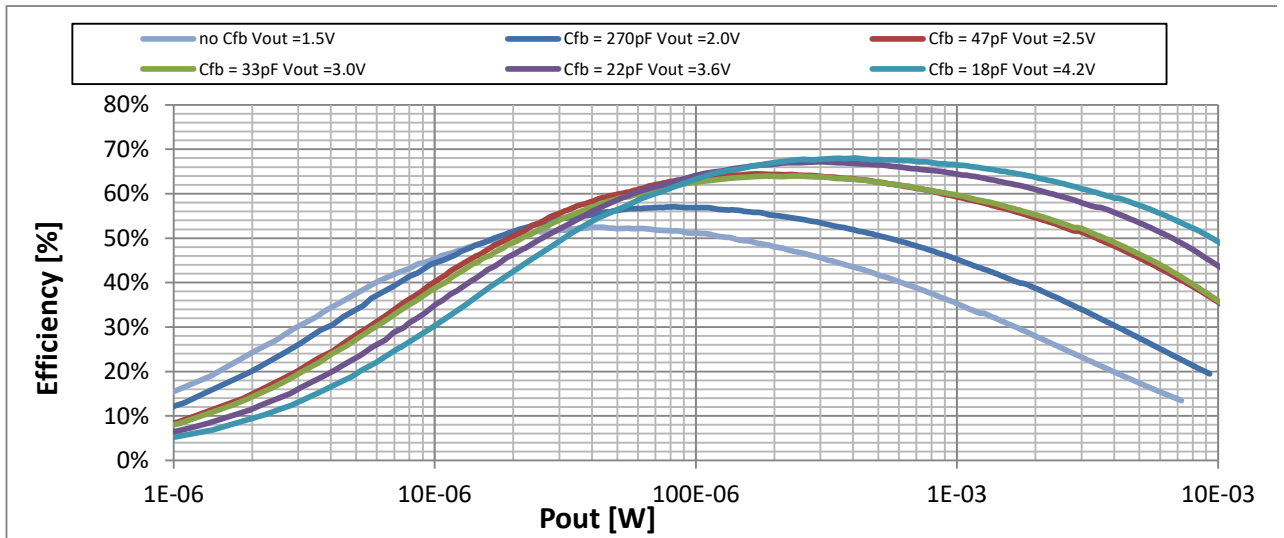

Figure 4-1: Efficiency over output power ; turn ratio 1:20

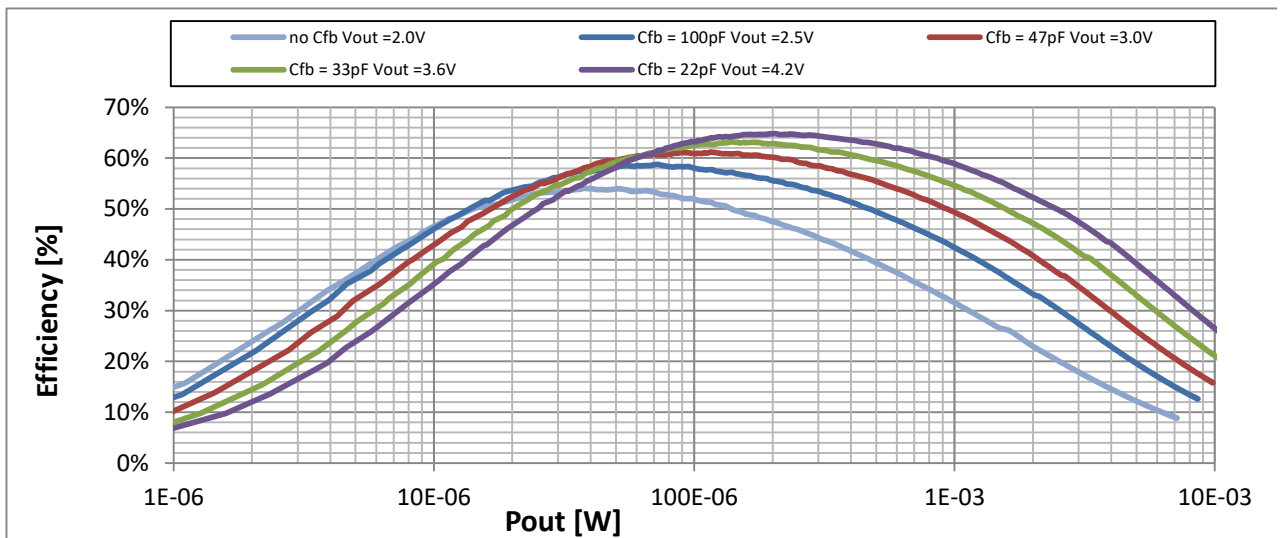

Figure 4-2: Efficiency over output power ; turn ratio 1:50

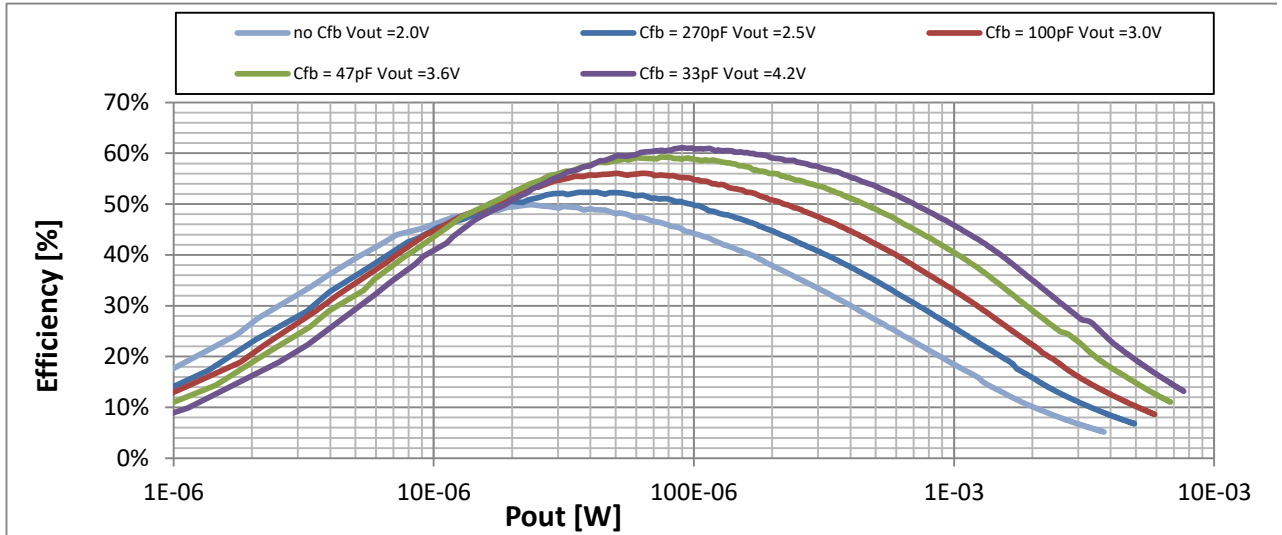

Figure 4-3: Efficiency over output power ; turn ratio 1:100

The input power P_{IN} is extracted from the charts as follows (η is the efficiency of the DCDC):

$$P_{IN} = \frac{P_{OUT}}{\eta}$$

Equation 2: Input Power Calculation

4.2 TEG OPEN VOLTAGE CALCULATION

The open voltage depends on the DCDC converter input power P_{IN} , the TEG electrical resistivity R_{TEG} and the DCDC converter input impedance R_{IN} .

The Figure 3-2 to Figure 3-8 allow extracting the DCDC input impedance R_{IN} as a function of P_{IN} , C_{FB} and the transformer turn ratio.

The TEG open voltage is calculated as follows:

$$V_{OV} = \sqrt{\frac{P_{IN} \cdot (R_{IN} + R_{TEG})^2}{R_{IN}}}$$

Equation 3: TEG Open Voltage Calculation

4.3 MINIMUM TEMPERATURE CALCULATION

The open voltage V_{OV} allows calculating the required temperature delta over the TEG as follows:

$$\Delta T_{GLOBAL} = \Delta T_{TEG} \cdot \frac{R_{TH} + R_{COOLER}}{R_{TH}} = \frac{V_{OV}}{\alpha} \cdot \frac{R_{TH} + R_{COOLER}}{R_{TH}}$$

Equation 4: Delta of Temperature Calculation

5. APPLICATION EXAMPLES

5.1 INDUSTRIAL APPLICATION

5.1.1 Definition of the application

This example assumes an industrial application operated with a TEG element attached to a hot water pipe on the hot side and connected to a cooling element $R_{COOLER} = 10$ [K/W] in ambient air on the cold side.

The electronic system requires an average power of 1 mW and must operate fully autonomously. The maximum output voltage is 4.2V.

5.1.2 Components selection

We arrive at the following selection of parameter values:

- The best transformer turn ratio is 1:20
- The ideal TEG thermal resistivity is 10 [K/W] to match with the cooler
- According to the Table 2, C_{FB} is 18 pF (VSUP = 4.2V ; Turn ratio = 1:20)
- According to the Figure 3-8, the ideal TEG electrical resistivity is about 4 Ω at 1 mW.

The following TEG by Marlow offers characteristics close to these values:

Part number:	NL1023T-01AC
Thermal resistivity R_{TH} :	11.30 [K/W]
Electrical resistivity R_{TEG} :	3.50 [Ω]
Seebeck coefficient α :	27 [mV/K]

5.1.3 Minimum delta temperature calculation

$$P_{OUT} = 1 \text{ mW}$$

$$\text{Turn ratio} = 1:20$$

According to the Figure 4-1 the efficiency at $P_{OUT} = 1$ mW is 62%

Thus the DCDC converter input power is $P_{IN} = 1.61$ mW

According to Figure 3-8 the input impedance of the DCDC converter is: $R_{IN} = 3.5 \Omega$ at 1.61mW

The electrical resistivity of the TEG is: $R_{TEG} = 3.5 \Omega$

According to the Equation 3, $V_{OV} = 150$ mV

$$R_{TH} = 11.3 \text{ K/W}$$

$$R_{COOLER} = 10 \text{ K/W}$$

$$\alpha = 27 \text{ mV/K}$$

According to the Equation 4 the delta temperature between the hot source and the ambient temperature must be at least:

$\Delta T_{GLOBAL} = 10.5 \text{ }^\circ\text{C}$ to get an output power $P_{OUT} = 1$ mW at VSUP = 4.2V.

5.1 WEARABLE APPLICATION

5.1.1 Definition of the application

This application example assumes a wearable device in contact with the skin on the hot side and TEG with a cooling element $R_{COOLER} = 100$ [K/W] in ambient air. The electronic system requires an average power of $20\mu\text{W}$ and operates fully autonomously. The maximum output voltage is 1.8V.

5.1.2 Components selection

We arrive at the following selection of parameter values:

- The best transformer turn ratio is 1:100 for wearable applications
- The ideal TEG thermal resistivity is 100 [K/W] to match with the cooler
- According to the Table 2, no C_{FB} is required (secondary side of transformer is directly connected to FB)
- According to the Figure 3-2, the ideal TEG electrical resistivity is about $2\ \Omega$ at $20\ \mu\text{W}$.

The following TEG by Marlow offers characteristics close to these values when 2 elements are electrically connected in series and thermally connected in parallel:

Part number:	1x NL1010T-01AC	2x NL1010T-01AC
Thermal resistivity R_{TH} :	191.40 [K/W]	95.7 [K/W]
Electrical resistivity R_{TEG} :	0.64 [Ω]	1.28 [Ω]
Seebeck coefficient α :	2.665 [mV/K]	5.33 [mV/K]

5.1.3 Minimum delta of temperature calculation

$$P_{OUT} = 20\ \mu\text{W}$$

$$\text{Turn ratio} = 1:100$$

According to the Figure 4-3 the efficiency at $P_{OUT} = 20\ \mu\text{W}$ is 50%. Thus the DCDC converter input power is $P_{IN} = 40\ \mu\text{W}$

According to Figure 3-2 the input impedance of the DCDC converter is: $R_{IN} = 1.3\ \Omega$ at $40\ \mu\text{W}$.

The electrical resistivity of the TEG is: $R_{TEG} = 1.28\ \Omega$

According to the Equation 3, $V_{OV} = 14\ \text{mV}$

$$R_{TH} = 97.5\ \text{K/W}$$

$$R_{COOLER} = 100\ \text{K/W}$$

$$\alpha = 5.33\ \text{mV/K}$$

According to the Equation 4 the delta temperature between the hot source and the ambient temperature must be at least:

$$\Delta T_{GLOBAL} = 5.4\ ^\circ\text{C} \text{ to get an output power } P_{OUT} = 20\ \mu\text{W} \text{ at } V_{SUP} = 1.8\text{V}.$$

DOCUMENT HISTORY

Release	Author	Date	Description
1.0	EM	October 19, 2016	Initial release
2.0	EM	December 12, 2016	Update charts and examples of calculation
3.0	EM	December 22, 2016	Small typo correction VSUP = 1.8V in second example

TABLE OF CONTENTS

1. SCOPE	2
2. BLOCK DIAGRAM	2
3. TEG AND EXTERNAL COMPONENTS SELECTION	3
3.1 Transformer turn ratio.....	3
3.1.1 <i>Wearable applications</i>	3
3.1.2 <i>Industrial applications</i>	3
3.2 Thermal resistivity R_{TH}	4
3.3 Feed-back capacitor C_{FB}	4
3.4 Electrical resistivity R_{TEG}	4
3.5 Seebeck coefficient	6
3.5.1 <i>Figure of merit</i>	6
3.6 AC coupling capacitor C_{AC}	7
3.7 Input capacitor C_{HRV}	7
4. PERFORMACNE CALCULATIONS	7
4.1 Input power calculation.....	7
4.2 TEG open voltage calculation.....	9
4.3 Minimum temperature calculation	9
5. APPLICATION EXAMPLES	10
5.1 Industrial application	10
5.1.1 <i>Definition of the application</i>	10
5.1.2 <i>Components selection</i>	10
5.1.3 <i>Minimum delta temperature calculation</i>	10
5.1 Wearable application.....	11
5.1.1 <i>Definition of the application</i>	11
5.1.2 <i>Components selection</i>	11
5.1.3 <i>Minimum delta of temperature calculation</i>	11

LIST OF TABLES

Table 1 List of Reference Transformers	3
Table 2: C_{FB} Capacitor Selection.....	4
Table 3: List of TEG	6
Table 4 C_{HRV} Capacitor Selection.....	7

LIST OF FIGURES

Figure 2-1: Block Diagram	2
Figure 3-1: Thermal Structure	4
Figure 3-2 Input Impedance vs Power No C_{FB}	5
Figure 3-3 Input Impedance vs Power C_{FB} 270 pF.....	5
Figure 3-4 Input Impedance vs Power C_{FB} 100 pF.....	5
Figure 3-5 Input Impedance vs Power C_{FB} 47 pF.....	5
Figure 3-6 Input Impedance vs Power C_{FB} 33 pF.....	5
Figure 3-7 Input Impedance vs Power C_{FB} 22 pF.....	5
Figure 3-8 Input Impedance vs Power C_{FB} 18 pF.....	5
Figure 4-1: Efficiency over output power ; turn ratio 1:20	8
Figure 4-2: Efficiency over output power ; turn ratio 1:50	8
Figure 4-3: Efficiency over output power ; turn ratio 1:100	9

LIST OF EQUATIONS

Equation 1 : Figure of merit of a TEG	6
Equation 2: Input Power Calculation.....	9
Equation 3: TEG Open Voltage Calculation.....	9
Equation 4: Delta of Temperature Calculation	9

EM Microelectronic-Marin SA ("EM") makes no warranties for the use of EM products, other than those expressly contained in EM's applicable General Terms of Sale, located at <http://www.emmicroelectronic.com>. EM assumes no responsibility for any errors which may have crept into this document, reserves the right to change devices or specifications detailed herein at any time without notice, and does not make any commitment to update the information contained herein.

No licenses to patents or other intellectual property rights of EM are granted in connection with the sale of EM products, neither expressly nor implicitly.

In respect of the intended use of EM products by customer, customer is solely responsible for observing existing patents and other intellectual property rights of third parties and for obtaining, as the case may be, the necessary licenses.

Important note: The use of EM products as components in medical devices and/or medical applications, including but not limited to, safety and life supporting systems, where malfunction of such EM products might result in damage to and/or injury or death of persons is expressly prohibited, as EM products are neither destined nor qualified for use as components in such medical devices and/or medical applications. The prohibited use of EM products in such medical devices and/or medical applications is exclusively at the risk of the customer