

## CURRENT CAPABILITY OF VSUP AND VAUX[2:0]

Product Family:	<b>EM85xx</b>
Part Number:	EM8500, EM8502, EM8504
Keywords:	Power management, Energy harvesting, Solar, TEG, MPPT, Configuration, Setup, Super capacitors, Secondary Battery, Primary Battery

### NOTIFICATION

The EM85xx naming shall be used in this document as a generic part number name for EM85xx devices.

### ABSTRACT

The EM85xx offers a NVM containing all the configuration parameters. This document describes how to setup the registers linked to output drive capability of the supplies VSUP and VAUX[2:0] used without LDO in the NVM

### ABBREVIATIONS

NVM	Non-Volatile-Memory
MCU	Microcontroller Unit
STS	Short term storage element (capacitor connected to VDD_STS)
LTS	Long term storage element (rechargeable battery connected to VDD_LTS)
HRV	Harvester, main source of energy (solar or TEG)
TEG	Thermoelectric Generator
VLD	Voltage Level Detector
Vref	Voltage level detector reference level
Vlvl	Voltage level detector LSB (71.88mV)
Vbat	Battery voltage connected to VDD_LTS
VSUP	Main output supply for application
VAUX[i]	2 independent auxiliary supplies for application
R <sub>BAT</sub>	Battery internal resistivity
R <sub>SW_LTS_STS</sub>	STS to LTS switch resistivity
R <sub>SW_VSUP</sub>	STS to VSUP switch resistivity
R <sub>SW_VAUXi</sub>	STS to VAUXi switch resistivity
I <sub>TOT</sub>	Total current flowing from LTS to VSUP and/or VAUXi
I <sub>STD</sub>	Total current flowing from LTS to VSUP and/or VAUXi in normal mode (low power)
I <sub>PEAK</sub>	Total current flowing from LTS to VSUP and/or VAUXi in high mode

## 1 SCOPE

The EM85xx delivers 4 output supplies:

1. VSUP: main supply output usually used for MCU
2. VAUX[2:0]: 3 supply outputs used for peripherals such as RF, sensors, actuator etc...  
Each supply output can be directly connected to STS or regulated. When the LDO is used, the maximum current the EM85xx can deliver is limited by the LDO drive capability. This document describes the way to configure the device when VSUP and/or VAUX[2:0] are directly connected to STS.

The following registers are involved for that action:

Register name	Address	Description
reg_v_bat_min_hi_con	0x0A	Minimum battery and application voltage when STS and LTS are connected, form an hysteresis with <b>v_bat_min_lo</b>
reg_v_bat_min_lo	0x0B	Absolute minimum value of the battery and the application
reg_v_apl_max_hi	0x0C	Absolute maximum application voltage (ignored if set to 0xFF)
reg_v_apl_max_lo	0x0D	Maximum application voltage low level of hysteresis (ignored if set to 0xFE)
reg_ldo_cfg	0x0E	Configuration of the LDO
reg_vaux_cfg	0x10	Configuration of VAUX[2:0]

**Table 1: List of Registers Related to Maximum Current Driven on VSUP and VAUX**

The default value after reset or start-up of the registers listed in [Table 1](#) is contained in a NVM memory at the following related addresses:

Register name	Register Address	Related address in NVM	
<i>reg_v_bat_min_hi_con</i>	0x0A	eprom10	0x4A
<i>reg_v_bat_min_lo</i>	0x0B	eprom11	0x4B
<i>reg_v_apl_max_hi</i>	0x0C	eprom12	0x4C
<i>reg_v_apl_max_lo</i>	0x0D	eprom13	0x4D
<i>reg_ldo_cfg</i>	0x0E	eprom14	0x4E
<i>reg_vaux_cfg</i>	0x10	eprom16	0x50

**Table 2: Mapping of Registers in EEPROM**

Note: the offset between the register addresses and related address in NVM is 0x40

## 2 DISABLE THE LDO

### 2.1 VSUP LDO

This part describes the way to configure the EM85xx devices, when no LDO is used. There are two conditions to keep the LDO on VSUP always disabled:

1. Set the register `reg_ldo_cfg.frc_ulp_ldo = '0'`
2. The voltage on STS shall be always lower than `v_apl_max_lo`

The easiest way to ensure that STS is always lower than `v_apl_max_lo` is to configure the device as follows:

`reg_v_apl_max_hi = 0xFF`  
`reg_v_apl_max_lo = 0xFE`

### 2.2 VAUX LDO

To ensure the VAUX LDO is always disabled, the device shall be configured as follows:

`reg_vaux_cfg = 0x00`

### 3 CURRENT FLOW

The storage elements STS and LTS are considered as connected in that description. It is not recommended to drive high current on VSUP and VAUX when STS and LTS are disconnected.

The current flows from the battery to VSUP and VAUX as follows:

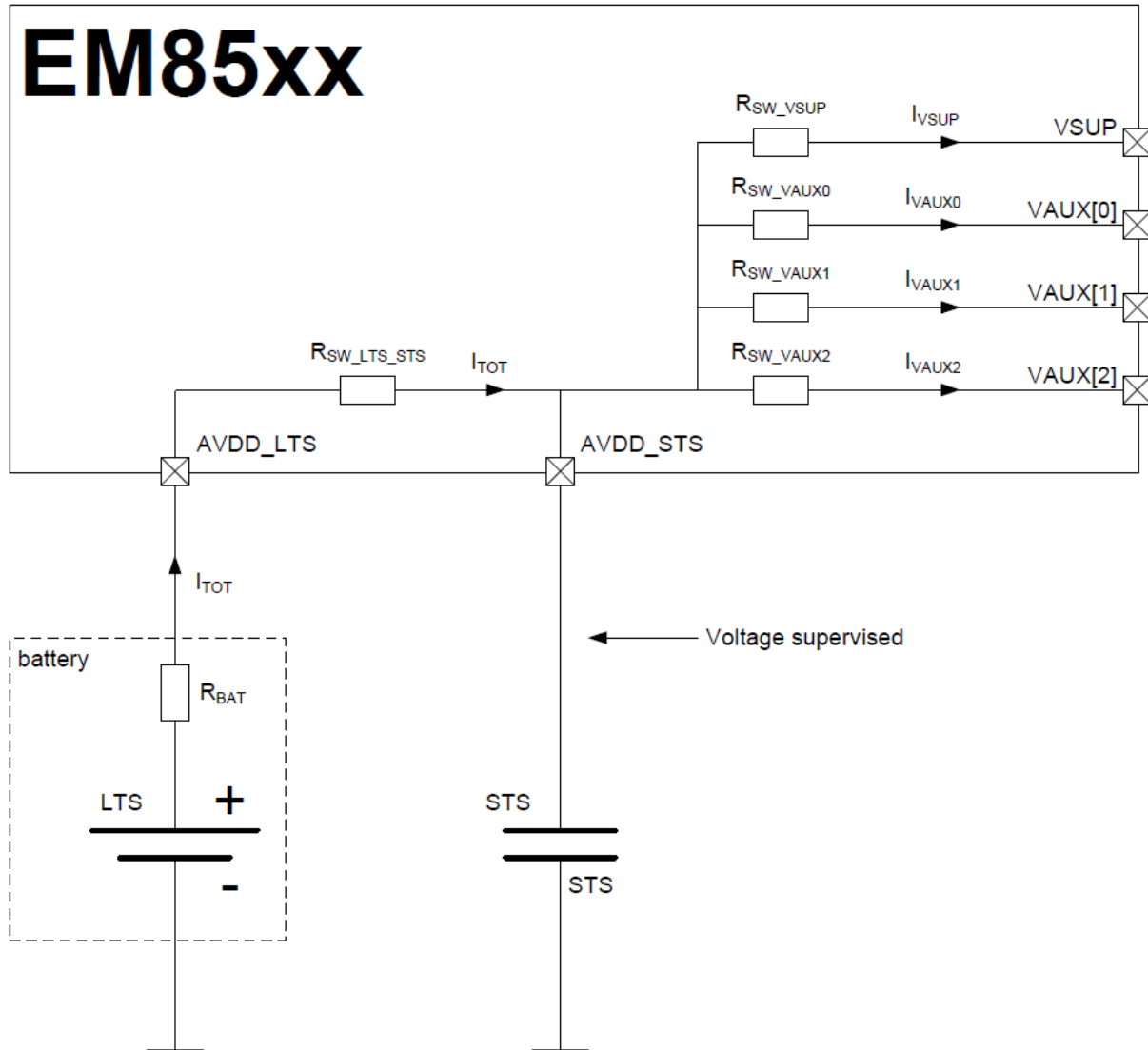

**Figure 1: Current Flow Diagram**

The current driven on VSUP and/or VAUX will generate a voltage drop on LTS and STS due to the different switches resistivity.

When STS and LTS are connected the EM85xx supervises STS.

When STS is detected lower than  $v\_bat\_min\_lo$ , it disables VSUP and VAUX[2:0] to protect the system against overload.

#### 4 REGISTER V\_BAT\_MIN\_HI\_CON CALCULATION

We consider 2 current levels:

1. Standard current  $I_{std}$ : total current load on VSUP and VAUX[2:0] in normal mode
2. Peak current  $I_{peak}$ : total peak current load on VSUP and VAUX[2:0] in high consumption mode

We consider the following worst case scenario:

The total charge current  $I_{TOT}$  is the sum of currents loaded on VSUP and VAUX[2:0].

The EM85xx is in normal mode and therefore  $I_{TOT} = I_{std}$ . The worst case is considered here – STS =  $v\_bat\_min\_hi\_con$  at the moment the current peak  $I_{peak}$  is driven on VSUP and/or VAUX[2:0]. The voltage on LTS and STS drops but shall remain above  $v\_bat\_min\_lo$  to keep the system working.

The following timing diagram illustrates this scenario:

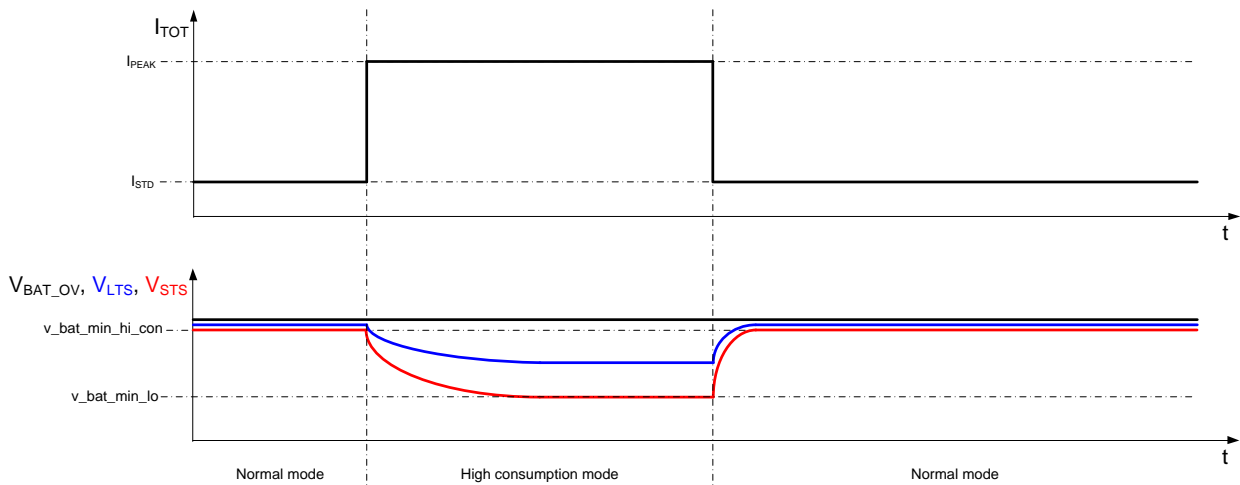

**Figure 2: Worst Case Scenario Timing Diagram**

The minimum delta between  $v\_bat\_min\_hi\_con$  and  $v\_bat\_min\_lo$  shall follow the following rules:

$$reg\_v\_bat\_min\_hi\_con \geq \text{trunc} \left( \frac{(I_{PEAK} - I_{STD}) \cdot (R_{BAT} + R_{SW\_LTS\_STS})}{\min(V_{lv})} \right) + reg\_v\_bat\_min\_lo + 1$$

**Equation 1: reg\_v\_bat\_min\_hi\_con Calculation**

Note: the values of  $RSW\_LTS\_STS$  and  $V_{lv}$  are in the datasheet in table 4-3.

If the result of that equation is higher than the one calculated by the wizard document, it shall replace it.

---

## TABLE OF CONTENTS

1	Scope.....	2
2	Disable the LDO.....	3
2.1	VSUP LDO.....	3
2.2	VAUX LDO.....	3
3	Current Flow.....	4
4	Register V_BAT_MIN_HI_CON CALCULATION .....	5

**LIST OF TABLES**

Table 1: List of Registers Related to Maximum Current Driven on VSUP and VAUX..... 2  
 Table 2: Mapping of Registers in EEPROM..... 2

**LIST OF FIGURES**

Figure 1: Current Flow Diagram ..... 4  
 Figure 2: Worst Case Scenario Timing Diagram ..... 5

**LIST OF EQUATIONS**

Equation 1: reg\_v\_bat\_min\_hi\_con Calculation ..... 5

EM Microelectronic-Marin SA (“EM”) makes no warranties for the use of EM products, other than those expressly contained in EM's applicable General Terms of Sale, located at <http://www.emmicroelectronic.com>. EM assumes no responsibility for any errors which may have crept into this document, reserves the right to change devices or specifications detailed herein at any time without notice, and does not make any commitment to update the information contained herein.

No licenses to patents or other intellectual property rights of EM are granted in connection with the sale of EM products, neither expressly nor implicitly.

In respect of the intended use of EM products by customer, customer is solely responsible for observing existing patents and other intellectual property rights of third parties and for obtaining, as the case may be, the necessary licenses.

**Important note: The use of EM products as components in medical devices and/or medical applications, including but not limited to, safety and life supporting systems, where malfunction of such EM products might result in damage to and/or injury or death of persons is expressly prohibited, as EM products are neither destined nor qualified for use as components in such medical devices and/or medical applications. The prohibited use of EM products in such medical devices and/or medical applications is exclusively at the risk of the customer**