

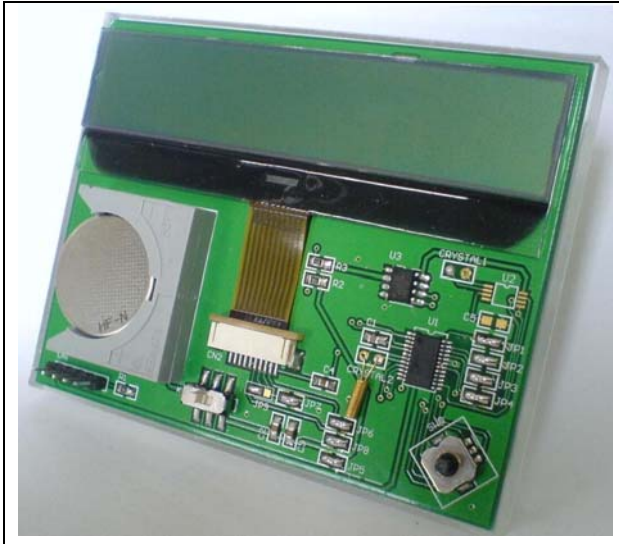

EM6121/EM6126 DemoKit User's Manual

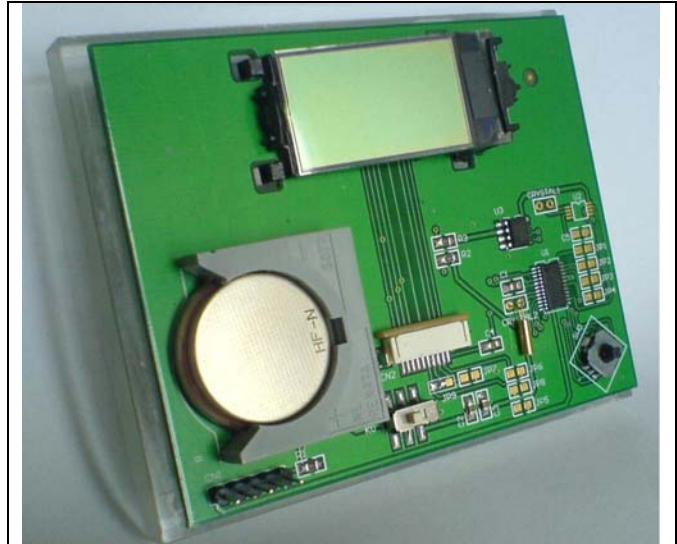

EMDB6121 : EM6121 Demo board



EMDB6126 : EM6126 Demo board

Description

The EMDB6121/26 is a standalone demo kit based on Character LCD drivers/controller EM6121 and Graphic LCD drivers/controller EM6126. This allows an easy evaluation of the EM6121/26.

A microcontroller EM6812 is used to send, receive commands and data through I2C or Serial bus.

This demo kit is delivered with pre-programmed firmware on EM6812. The firmware runs several demos to show EM6121/26 performance.

Different configurations can be set by jumpers (I2C address, Serial mode, power supply ...)

A joystick allows starting and setting up of the demo show.

The EM6121/26 demo kit contains LCD glass, PCB with EM6121/26 and EM6812.

All the latest documentation versions are published on the EM Microelectronic website www.emmicroelectronic.com

Features

- Character / Graphic LCD glass (STN Grey Reflective Positive Mode)
- 4 axis joystick with push button
- 3V Lithium battery
- RTC EM3027 TSSOP8
- 32 kHz oscillator
- 5 pin connector for microcontroller programming
- PCB equipped with EM6812 TSSOP24
- All Commons and segments are outputted on connector
- ROHS compliant

Ordering Information

Description	Part Number
EM6121 Demo kit	EMDB6121+
EM6126 Demo kit	EMDB6126+



EMDB6121

EMDB6126

EM6121 Quick Start

Joystick : Down ▼ Up ▲ Left ◀ Right ▶

Display	Actions	
* EM6121 Demo *		
▼ ▲ VLCD	◀ ▶	Adjust VLCD ▼ ▲
▼ ▲ FONT	◀ ▶	Display ROM font content (16 characters displayed) ▼ ▲ Display ROM Font
▼ ▲ ICONS	◀ ▶	Display Icons ▲ Icons Off ▼ Icons On
▼ ▲ INV VIDEO	◀ ▶	Inverse video ▲ Inversed ▼ Normal
▼ ▲ CHECKER	◀ ▶	Checker ▲ Checker ▼ Normal
▼ ▲ Double Line	◀ ▶	Double Line ▲ Double line ▼ Normal line
▼ ▲ Version 100		

EM6126 Quick Start

Display	Actions	
1	Enter	Checker / Normal
◀ ▶ 2	Enter	Adjust VLCD ▼ ▲
◀ ▶ 3	Enter	Inverse/normal video
◀ ▶ 4	Enter	Display Small Picture



EMDB6121 EMDB6126

Settings

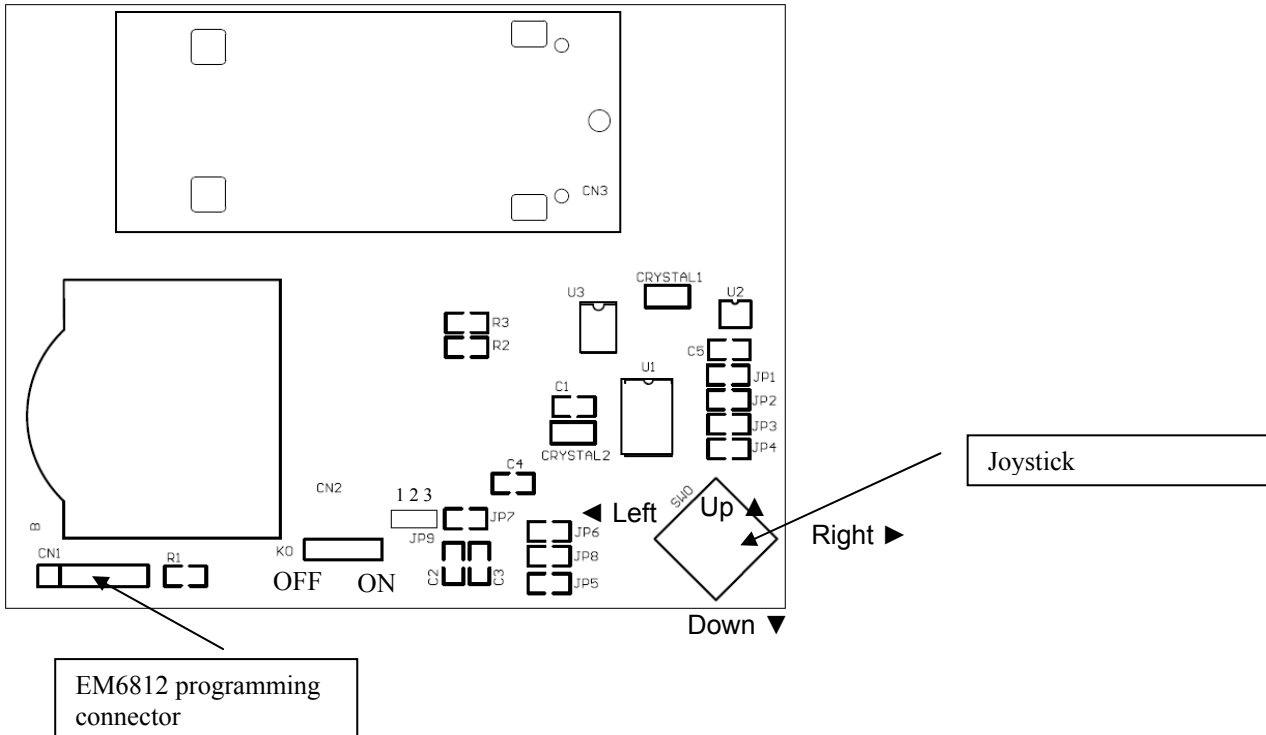

Jumper		Description		Default
		Open	Close	
JP1	CS	External host	Chip Select (CS) connected to EM6812 (PB3)	Close
JP2	RES	External host	RES connected to EM6812 (PB2)	Close
JP3	SCL	External host	SCL is generated by EM6812 (PB1)	Close
JP4	SDA	External host	SDA is generated by EM6812 (PB0)	Close
JP5	VDDMICRO	External power supply	Battery power supply selected	Close
JP6	VHV	External power supply	Battery power supply selected	Close
JP7	GNDLCD	External power supply	GNDLCD is connected to battery ground	Close
JP8	VDD	External power supply	Battery power supply selected	Close

Only for EM6121

Jumper		Description / Jumper position		Default
		1-2	2-3	
JP9	I	I2C protocol	3 wires interface	2-3



EMDB6121 EMDB6126

EM6121 LCD Mapping

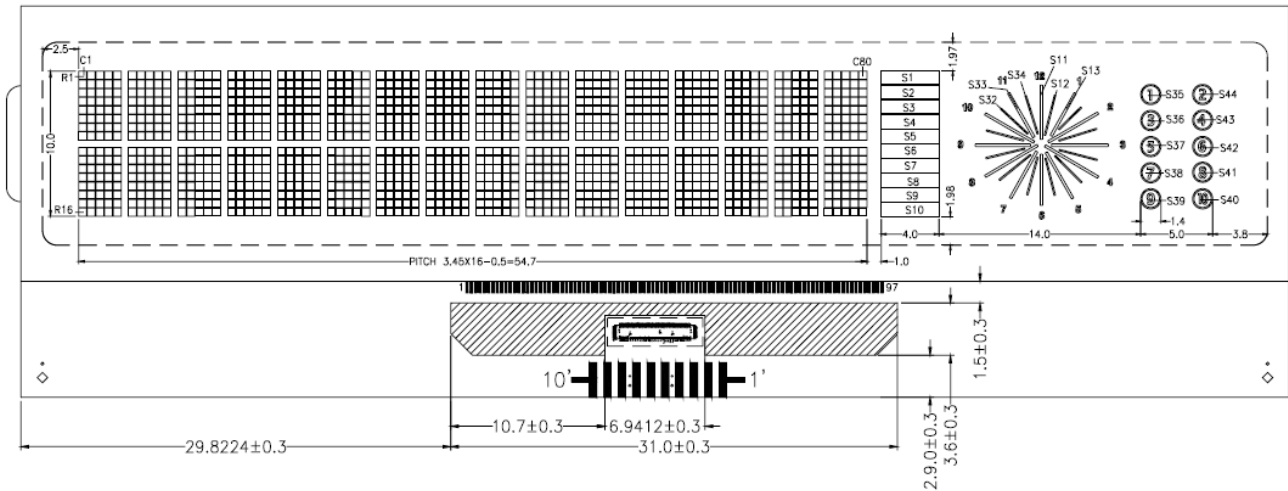

Pad #	PAD NAME	LCD	GLASS	COMS
1	R0	97	COMS	
2	R1	96	COM1	
3	R2	95	COM2	
4	R3	94	COM3	
5	R4	93	COM4	
6	R5	92	COM5	
7	R6	91	COM6	
8	R7	90	COM7	
9	R8	89	COM8	
10	R9	Not connected		
11	R10	Not connected		
12	R11	Not connected		
13	R12	Not connected		
14	C0	88	SEG80	S1
15	C1	87	SEG79	S2
16	C2	86	SEG78	S3
17	C3	85	SEG77	S4
18	C4	84	SEG76	S5
19	C5	83	SEG75	S6
20	C6	82	SEG74	S7
21	C7	81	SEG73	S8
22	C8	80	SEG72	S9
23	C9	79	SEG71	S10
24	C10	78	SEG70	10
25	C11	77	SEG69	9
26	C12	76	SEG68	8
27	C13	75	SEG67	S23
28	C14	74	SEG66	6
29	C15	73	SEG65	S24
30	C16	72	SEG64	S25
31	C17	71	SEG63	7
32	C18	70	SEG62	S26
33	C19	69	SEG61	S27
34	C20	68	SEG60	S28
35	C21	67	SEG59	S29
36	C22	66	SEG58	S30
37	C23	65	SEG57	S31
38	C24	64	SEG56	S32
39	C25	63	SEG55	11

Pad #	PAD NAME	LCD	GLASS	COMS
40	C26	62	SEG54	S33
41	C27	61	SEG53	S34
42	C28	60	SEG52	12
43	C29	59	SEG51	S11
44	C30	58	SEG50	S12
45	C31	57	SEG49	S13
46	C32	56	SEG48	1
47	C33	55	SEG47	S14
48	C34	54	SEG46	S15
49	C35	53	SEG45	2
50	C36	52	SEG44	S16
51	C37	51	SEG43	S17
52	C38	50	SEG42	3
53	C39	49	SEG41	S18
54	C40	48	SEG40	S19
55	C41	47	SEG39	4
56	C42	46	SEG38	S20
57	C43	45	SEG37	S21
58	C44	44	SEG36	5
59	C45	43	SEG35	S22
60	C46	42	SEG34	S35
61	C47	41	SEG33	S36
62	C48	40	SEG32	S37
63	C49	39	SEG31	S38
64	C50	38	SEG30	S39
65	C51	37	SEG29	S40
66	C52	36	SEG28	S41
67	C53	35	SEG27	S44
68	C54	34	SEG26	S43
69	C55	33	SEG25	S42
70	C56	32	SEG24	
71	C57	31	SEG23	
72	C58	30	SEG22	
73	C59	29	SEG21	
74	C60	28	SEG20	
75	C61	27	SEG19	
76	C62	26	SEG18	
77	C63	25	SEG17	
78	C64	24	SEG16	



EMDB6121 EMDB6126

Pad #	PAD NAME	LCD	GLASS	COMS
79	C65	23	SEG15	
80	C66	22	SEG14	
81	C67	21	SEG13	
82	C68	20	SEG12	
83	C69	19	SEG11	
84	C70	18	SEG10	
85	C71	17	SEG9	
86	C72	16	SEG8	
87	C73	15	SEG7	
88	C74	14	SEG6	
89	C75	13	SEG5	
90	C76	12	SEG4	
91	C77	11	SEG3	
92	C78	10	SEG2	
93	C79	9	SEG1	
94	R25	Not connected		
95	R24	Not connected		
96	R23	Not connected		
97	R22	Not connected		
98	R21	Not connected		
99	R20	8	COM16	
100	R19	7	COM15	
101	R18	6	COM14	
102	R17	5	COM13	
103	R16	4	COM12	
104	R15	3	COM11	
105	R14	2	COM10	
106	R13	1	COM9	
107	RES	RES		
108	SCL	SCL		
109	CS	CS		

Pad #	PAD NAME	LCD	GLASS	COMS
110	SDA	SDA		
111	VDD1	VDD1		
112	VDD1	VDD1		
113	VDD2 (alim_ref)	VDD2		
114	VDD2 (alim)	VDD2		
115	I	I		
116	VSS1	VSS		
117	VSS2 (VSS_buffers)	VSS		
118	FR	Not connected		
119	VSS2 (VSS_osc)	VSS		
120	TEST	VSS		
121	VSS2 (VSS_ref)	VSS		
122	VSS3 (masse)	VSS		
123	VSS3 (masse)	VSS		
124	VHV	VHV		
125	VHV	VHV		
126	VPP	VHV		
127	VLCD_SENSE	VLCD		
128	VLCD	VLCD		
129	VLCD	VLCD		
130	VLCD_OUT	VLCD		
131	VLCD_OUT	VLCD		
132	CP2	Not connected		
133	CP1	Not connected		
134	CP4	Not connected		
135	CP3	Not connected		
136	CP6	Not connected		
137	CP5	Not connected		

EM6121 Configuration

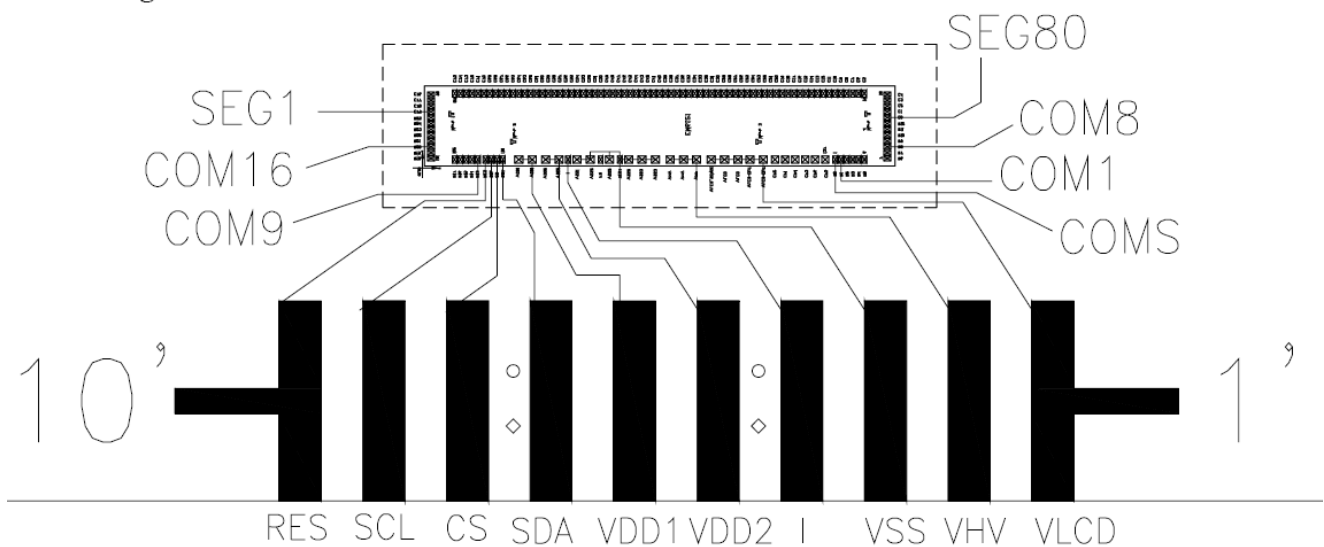

EM6126 Configuration



EMDB6121

EMDB6126

Moulding: no com/seg tracks
out of molding area

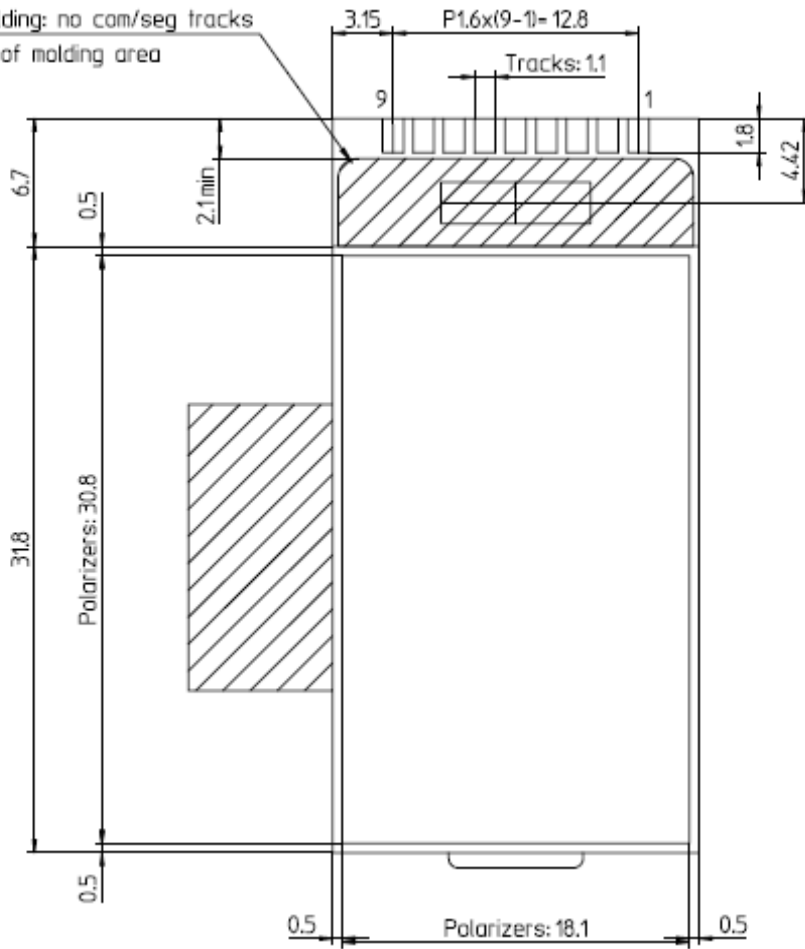

PIN IO	
1	RES
2	CS
3	VHV
4	VDD
5	VSS2
6	VSS1
7	VLCD
8	SCL
9	SDA



EMDB6121

EMDB6126

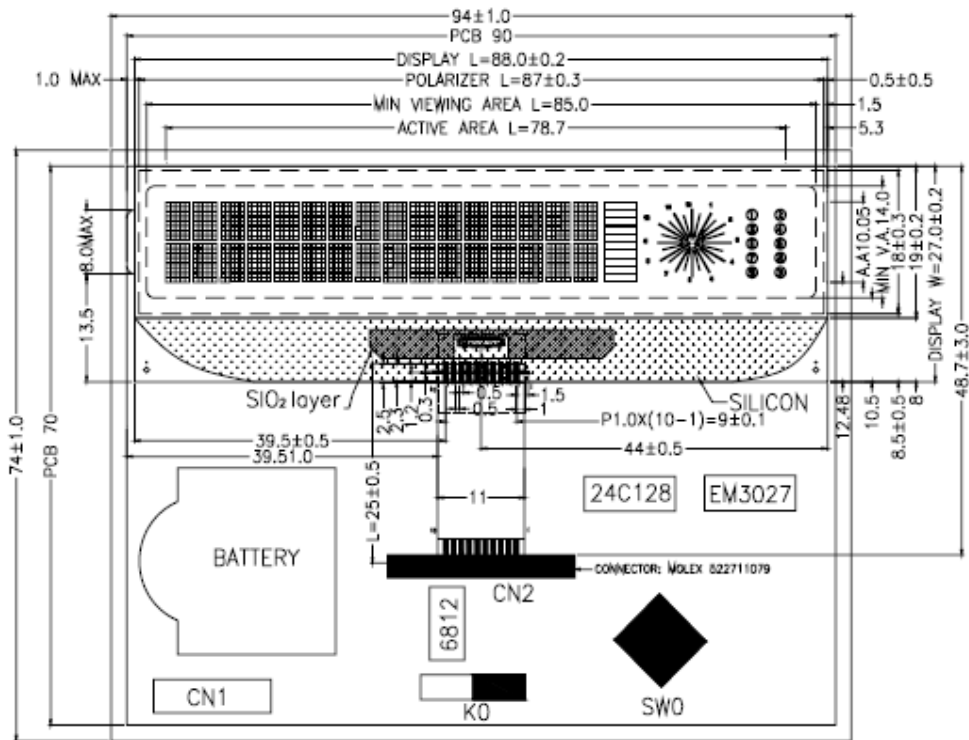

EMDB6126

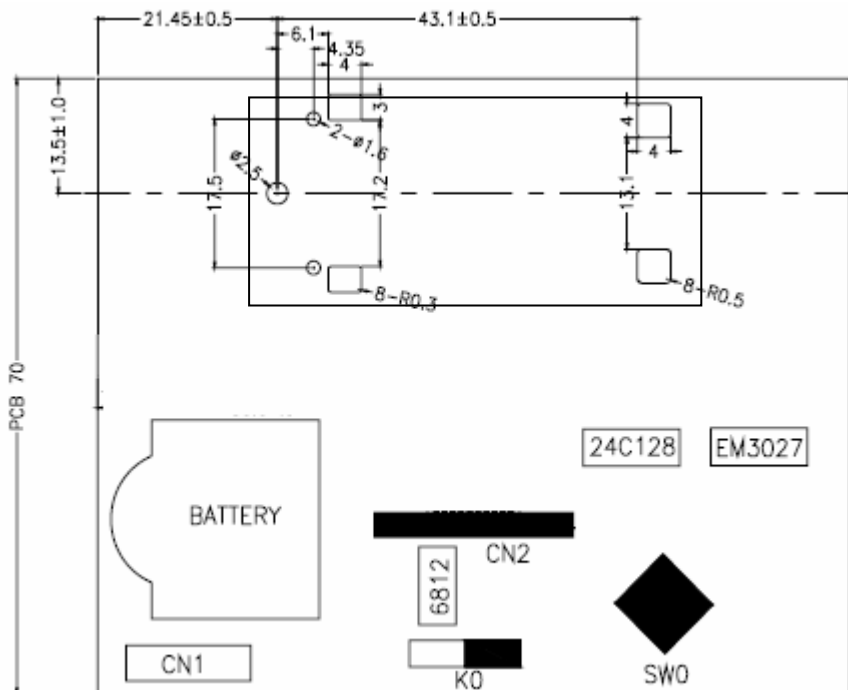



EMDB6121

EMDB6126

Bill of Materials

N°	Description	Reference
U1	8 bit Microcontroller	EM6812 TSSP24
U2	RTC EM3027	EM3027
U3	EEPROM 24C128	AT24C128
B	Renata Lithium Battery	CR2450N
S0	Renata Battery holder	NL5077
SW0	Joystick + Push button	ALPS SKRHABE010
R1	Resistor	1K Ohms
XT1	Crystal 32kHz	Microcrystal
XT2	Crystal 32kHz	Microcrystal
C1	Capacitor	470nF
C2	Capacitor	100nF
C3	Capacitor	1uF
C4	Capacitor	1uF
C5	Capacitor	1uF
K0	ON/OFF Switch	
JP1-JP9	Jumpers	



EMDB6121

EMDB6126

Programming

EMPB2 programmer

EMPB2 Connector	CN1	Description
1	1	VDD
6	2	PB7
8	3	PB5
7	4	VSS
10	5	TEST

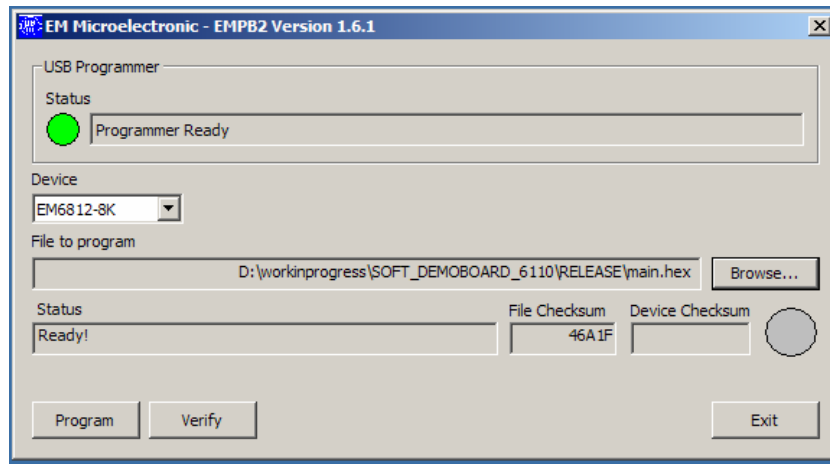

- 1- Connect USB cable on PC
- 2- Connect Programming cable on target (CN1)
- 3- Execute EMPB2
- 4- Choose EM6812-8K microcontroller
- 5- Browse main.hex
- 6- Program Microcontroller
- 7- Remove Programming cable
- 8- Power ON

EM Microelectronic-Marín SA (EM) makes no warranty for the use of its products, other than those expressly contained in the Company's standard warranty which is detailed in EM's General Terms of Sale located on the Company's web site. EM assumes no responsibility for any errors which may appear in this document, reserves the right to change devices or specifications detailed herein at any time without notice, and does not make any commitment to update the information contained herein. No licenses to patents or other intellectual property of EM are granted in connection with the sale of EM products, expressly or by implications. EM's products are not authorized for use as components in life support devices or systems.