



Application Note 603003
Title: **DTCXO Temperature Compensated Real Time Clock / Calendar Module with SPI Interface**
Product Family: **RV-3049**
Part Number: **RV-3049**

TABLE OF CONTENTS

1. OVERVIEW	4
1.1. GENERAL DESCRIPTION	4
1.2. APPLICATIONS	4
2. BLOCK DIAGRAM	5
2.1. PINOUT	6
2.2. PIN DESCRIPTION	7
2.3. FUNCTIONAL DESCRIPTION	7
2.4. DEVICE PROTECTION DIAGRAM	8
3. REGISTER ORGANIZATION	9
3.1. REGISTER OVERVIEW	9
3.2. CONTROL PAGE REGISTER FUNCTION	10
3.2.1. CONTROL_1 (address 00h...bits description)	10
3.2.2. CONTROL_INT (address 01h...bits description)	10
3.2.3. CONTROL_INT FLAG (address 02h...bits description)	11
3.2.4. CONTROL_STATUS (address 03h...bits description)	11
3.2.5. CONTROL_RESET (address 04h...bits description)	12
3.3. WATCH PAGE REGISTER FUNCTION	12
3.3.1. SECONDS, MINUTES, HOURS, DAYS, WEEKDAYS, MONTHS, YEARS REGISTER	12
3.3.2. DATA FLOW OF TIME AND DATE FUNCTION	14
3.4. ALARM PAGE REGISTER FUNCTION	15
3.4.1. SECONDS, MINUTES, HOURS, DAYS, WEEKDAYS, MONTHS, YEARS ALARM REGISTER	15
3.5. TIMER PAGE REGISTER FUNCTION	17
3.6. TEMPERATURE PAGE REGISTER FUNCTION	17
3.7. EEPROM DATA PAGE REGISTER FUNCTION	17
3.8. EEPROM CONTROL PAGE REGISTER FUNCTION	18
3.8.1. EEPROM CONTROL (address 30h...bits description)	18
3.8.2. XTAL OFFSET (address 31h...bits description)	18
3.8.3. XTAL TEMPERATUR COEFFICIENT (address 32h...bits description)	18
3.8.4. XTAL TURNOVER TEMPERATUR COEFFICIENT T0 (address 33h...bits description)	19
3.9. RAM DATA PAGE REGISTER FUNCTION	19
4. DETAILED FUNCTIONAL DESCRIPTION	20
4.1. POWER-UP, POWER MANAGEMENT AND BATTERY SWITCHOVER	20
4.1.1. POWER UP SEQUENCE	21



4.1.2. SUPPLY VOLTAGE OPERATING RANGE AND LOW VOLTAGE DETECTION	22
4.2. RESET	24
4.2.1. POWER-UP RESET, SYSTEM RESET AND SELF-RECOVERY RESET	24
4.2.2. REGISTER RESET VALUES	25
4.3. EEPROM MEMORY ACCESS	27
4.4. TIMER FUNCTION	28
4.4.1. TIMER INTERRUPT	30
4.5. ALARM FUNCTION	31
4.5.1. ALARM INTERRUPT	32
4.6. INTERRUPT OUTPUT INT	33
4.7. WATCH ENABLE FUNCTION	34
4.8. SELF-RECOVERY SYSTEM	34
4.9. CLOCK OUTPUT CLKOUT	35
5. COMPENSATION OF FREQUENCY DEVIATION AND FREQUENCY DRIFT vs TEMPERATURE	36
5.1. TEMPERATURE CHARACTERISTICS TUNING FORK CRYSTAL	36
5.2. COMPENSATION PRINCIPLE	37
5.2.1. THERMOMETER AND TEMPERATURE VALUE	38
5.2.2. SETTING THE FREQUENCY COMPENSATION PARAMETERS	39
5.3. METHOD OF COMPENSATING THE FREQUENCY DEVIATION	40
5.3.1. CORRECT METHOD FOR TESTING THE TIME ACCURACY	41
5.3.2. TESTING THE TIME ACCURACY USING CLKOUT OUTPUT	41
5.3.3. TESTING THE TIME ACCURACY USING INTERRUPT OUTPUT 1 Hz	42
5.4. TIME ACCURACY OPT: A / OPT: B	44
6. SPI INTERFACE	46
6.1. SPI INTERFACE SYSTEM CONFIGURATION	46
6.2. SPI INTERFACE DATA TRANSMISSION	48
6.2.1. COMMAND BYTE DEFINITION	48
6.2.2. SPI INTERFACE READ / WRITE EXAMPLES	49
7. ELECTRICAL CHARACTERISTICS	51
7.1. ABSOLUTE MAXIMUM RATINGS	51
7.2. FREQUENCY AND TIME CHARACTERISTICS	51
7.3. STATIC CHARACTERISTICS	52
7.4. SPI INTERFACE TIMING CHARACTERISTICS	53
7.5. SPI INTERFACE DYNAMIC CHARACTERISTICS	54
8. APPLICATION INFORMATION	55
8.1. RECOMMENDED REFLOW TEMPERATURE (LEADFREE SOLDERING)	56
9. PACKAGE	57
9.1. DIMENSIONS AND SOLDERPADS LAYOUT	57
9.2. MARKING AND PIN #1 INDEX	58
10. PACKING INFORMATION	59



10.1. CARRIER TAPE..... 59
10.2. PARTS PER REEL..... 60
10.3. REEL 13 INCH FOR 12 mm TAPE..... 61
10.4. REEL 7 INCH FOR 12 mm TAPE..... 62
11. HANDLING PRECAUTIONS FOR CRYSTALS OR MODULES WITH EMBEDDED CRYSTALS 63

RV-3049

Highly accurate, DTCXO Temperature Compensated Real Time Clock / Calendar Module with SPI Interface

1. OVERVIEW

- RTC module with built-in “Tuning Fork” crystal oscillating at 32.768 kHz
- Factory calibrated, all built-in Temperature Compensation circuitry

Time accuracy:	Temperature Range	Opt: A	Opt: B
	25°C	+/- 3 ppm	+/- 3 ppm
	0°C to + 50°C	+/- 4 ppm	+/- 5 ppm
	-10°C to + 60°C	+/- 5 ppm	+/- 10 ppm
	-40°C to + 85°C	+/- 6 ppm	+/- 25 ppm
	-40°C to +125°C	+/- 8 ppm	+/- 30 ppm

- Ultra low power consumption: 800nA typ @ $V_{DD} = 3.0V / T_{amb} = 25^{\circ}C$
- Wide clock operating voltage: 1.3 – 5.5V
- Wide interface operating voltage: 1.4 – 5.5V
- Extended operating temperature range: -40°C to +125°C
- SPI serial interface with fast mode SCL clock frequency of 1 MHz
- Provides year, month, day, weekday, hours, minutes and seconds
- Highly versatile alarm and timer functions
- Integrated Low-Voltage Detector, Power-On Reset and Self-Recovery System
- Main Power Supply to Backup Battery switchover circuitry with Trickle Charger
- Programmable CLKOUT pins for peripheral devices (32.768 kHz / 1024 Hz / 32 Hz / 1 Hz)
- Available in a small and compact package sizes, RoHS-compliant and 100% leadfree:
C3: 3.7 x 2.5 x 0.9 mm

1.1. GENERAL DESCRIPTION

The RV-3049 is a CMOS low power, real-time clock/calendar module with built-in Thermometer and Digital Temperature Compensation circuitry (DTCXO). The temperature compensation circuitry is factory-calibrated and greatly improves the time accuracy by compensating the frequency-deviation @ 25°C and the anticipated frequency-drift over the temperature of the embedded 32.768 kHz “Tuning-Fork” crystal, even over the extended Temperature Range -40°C to +125°C. Data is transferred serially via a SPI interface with a maximum SCL clock frequency in fast mode of 1 MHz, the built-in word address register is incremented automatically after each written or read data byte. Beyond standard RTC-functions like year, month, day, weekday, hours, minutes, seconds information, the RV-3049 offers highly versatile Alarm and Timer-Interrupt function, programmable Clock-Output and Low-Voltage Detector.

1.2. APPLICATIONS

The RV-3049 RTC module combines key functions with outstanding performance in a small ceramic package:

- Factory calibrated Temperature Compensation
- Extended temperature range up to +125°C
- Low Power consumption
- Smallest temperature compensated RTC module with embedded Xtal

These unique features make this product perfectly suitable for many applications:

- Automotive: Car Radio / GPS and Tracking Systems / Dashboard / Engine Controller / Car Mobile & Entertainment Systems / Tachometers
- Metering: E-meter / Heating Counter
- Outdoor: ATM & POS systems / Surveillance & Safety systems / Ticketing systems
- All kind of portable and battery operated devices
- Industrial and consumer electronics
- White goods

2. BLOCK DIAGRAM

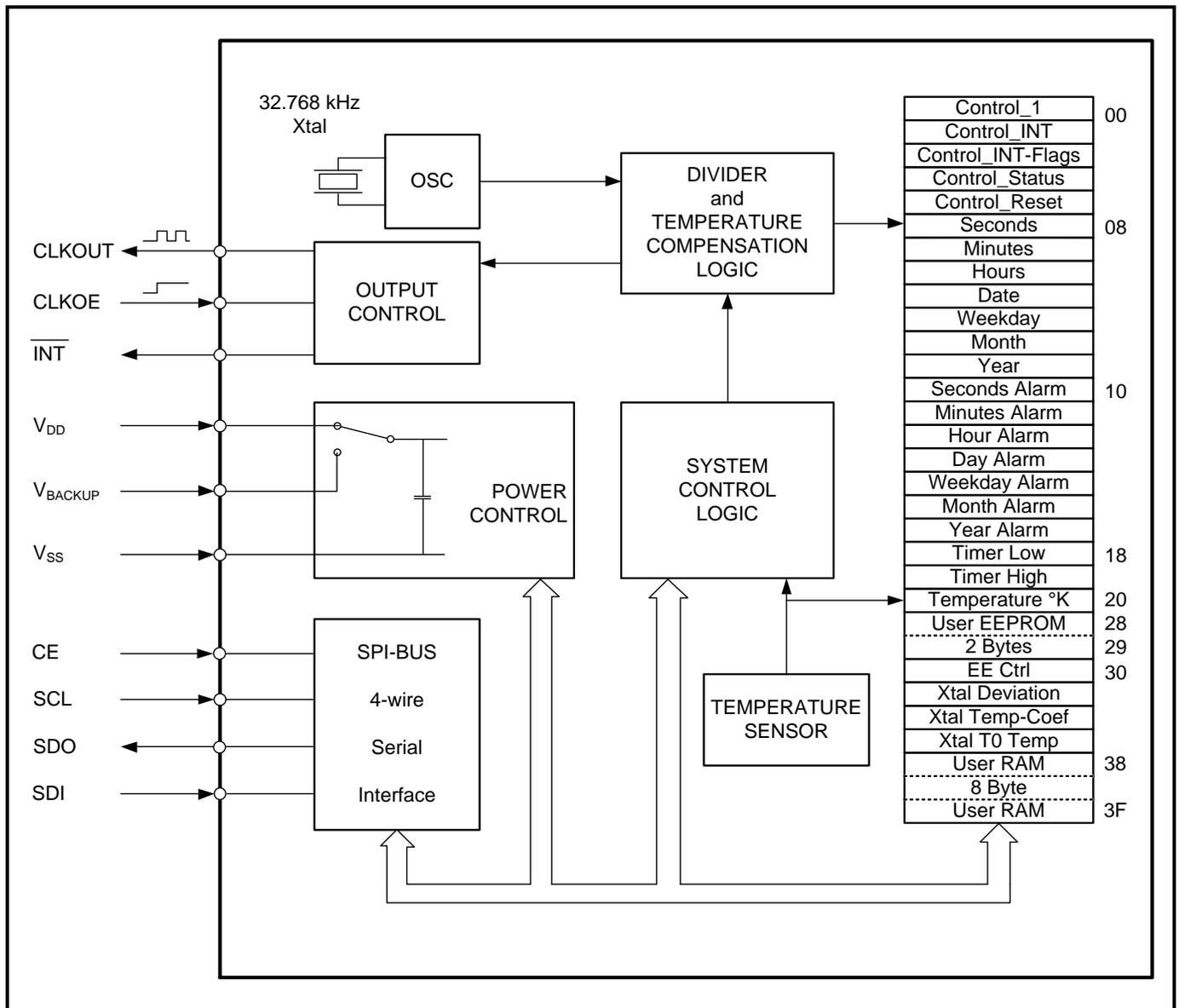

2.1. PINOUT

C3 Package:

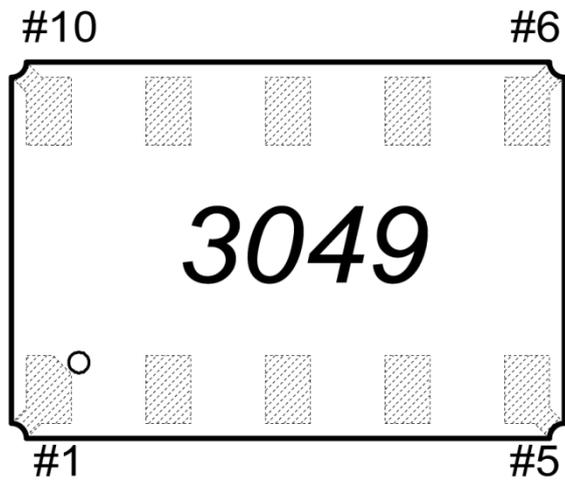

#1	CLKOE	#10	SDI
#2	V _{DD}	#9	V _{BACKUP}
#3	CLKOUT	#8	CE
#4	SCL	#7	$\overline{\text{INT}}$
#5	SDO	#6	V _{SS}



2.2. PIN DESCRIPTION

Symbol	Pin #	Description
	C3	
V _{DD}	2	Positive supply voltage; positive or negative steps in supply voltage may affect oscillator performance, recommend 10 nF decoupling capacitor close to device
CLKOUT	3	Clock Output pin; CLKOUT or $\overline{\text{INT}}$ function can be selected.(Control_1; bit7; Clk/Int) CLKOUT output push-pull / $\overline{\text{INT}}$ function open-drain requiring pull-up resistor
CE	8	Chip Enable Input pin; active HIGH
SCL	4	Serial Clock Input pin; may float when CE inactive
SDO	5	Serial Data Output pin; push-pull; high impedance when not driving; can be connected to SDI for single wire data line
V _{SS}	6	Ground
$\overline{\text{INT}}$	7	Interrupt Output pin; open-drain; active LOW
V _{BACKUP}	9	Backup Supply Voltage; tie to GND when not using backup supply voltage
SDI	10	Serial Data Input pin; may float when CE inactive
CLKOE	1	CLKOUT enable/disable pin; enable is active HIGH; tie to GND when not using CLKOUT

2.3. FUNCTIONAL DESCRIPTION

The RV-3049 is a highly accurate real-time clock/calendar module due to integrated temperature compensation circuitry. The built-in Thermometer and Digital Temperature Compensation circuitry (DTCXO) provides improved time-accuracy; achieved by measuring the temperature and calculating an expected correction value based on precise, factory-calibrated Crystal parameters. The compensation of the frequency deviation @ 25°C and the Crystal's frequency-drift over the temperature range are obtained by adding or subtracting 32.768 kHz oscillator clock-pulses. Beyond standard RTC-functions like year, month, day, weekday, hours, minutes, seconds information, the RV-3049 offers highly versatile Alarm and Timer-Interrupt function, programmable Clock-Output and Voltage-Low-Detector and a Main-Supply to Backup-Battery Switchover Circuitry and a SPI interface.

The CMOS IC contains thirty 8-bit RAM registers organized in 6 memory pages; the address counter is automatically incremented within the same memory page. All sixteen registers are designed as addressable 8-bit parallel registers, although, not all bits are implemented.

- **Memory page #00** contains of five registers (memory address 00h and 04h) used as control registers
- **Memory page #01** addresses 08h through 0Eh are used as counters for the clock function (seconds up to years). The Seconds, Minutes, Hours, Days, Weekdays, Months and Years registers are all coded in Binary-Coded-Decimal (BCD) format. When one of the RTC registers is read, the content of all counters is frozen to prevent faulty reading of the clock/calendar registers during a carry condition
- **Memory page #02** addresses 10h through 16h define the alarm condition
- **Memory page #03** addresses 18h and 19h are used for Timer function
- **Memory page #04** address 20h provides the thermometer reading value
- **Memory page #07** addresses 38h through 3Fh are available for user data

Additionally, the CMOS-IC contains six non-volatile 8-bit EEPROM registers organized in 2 memory pages; the address counter is automatically incremented within the same memory page.

- **EEPROM page #05** addresses 28h and 29h are available for EEPROM user data
- **EEPROM page #06** contains of four registers (memory address 30h through 33h) used as non-volatile control registers. These registers contain the factory programmed parameters of the Crystal's thermal characteristics, the frequency-deviation @ ambient temperature and the Thermometer's calibration values. In favour for the best time-accuracy, the factory programmed registers (memory address 31h through 33h) shall not be changed by the user without carefully studying its function

2.4. DEVICE PROTECTION DIAGRAM

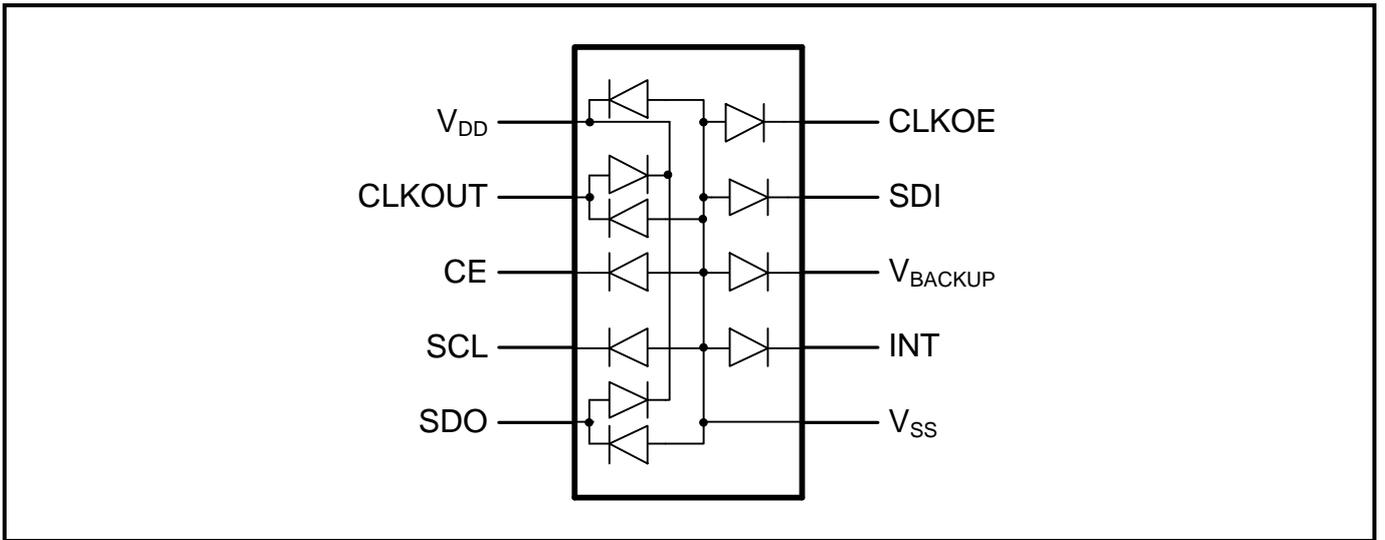

3. REGISTER ORGANIZATION

The registers are grouped into memory pages. The pages are addressed by the 5 most-significant-bits (MSB's bits 7 – 3), the 3 least-significant-bites (LSB's 2 – 0) select the registers within the addressed page.

30 RAM registers organized in 6 memory pages and 6 EEPROM registers organized in 2 memory pages are available. During interface access, the page address (MSB's 7 - 3) is fixed while the register address (LSB's 2 - 0) are automatically incremented. The content of all counters and registers are frozen to prevent faulty reading of the clock/calendar registers during carry condition.

The time registers in the Clock and Alarm pages are encoded in the Binary Coded Decimal format (BCD) to simplify application use. Other registers are either bit-wise or standard binary format.

3.1. REGISTER OVERVIEW

Address			Function	Bit 7	Bit 6	Bit 5	Bit 4	Bit 3	Bit 2	Bit 1	Bit 0
Page Bit 7 - 3	Address Bit 2 - 0	Hex									
Control page 00000	000	00h	Control_1								
	001	01h	Control_INT	X	X	X					
	010	02h	Control_INT Flag	X	X	X					
	011	03h	Control_Status	EEbusy	X	PON					
	100	04h	Control_Reset	X	X	X	SysR	X	X	X	X
Clock page 00001	000	08h	Seconds	X	40	20	10	8	4	2	1
	001	09h	Minutes	X	40	20	10	8	4	2	1
	010	0Ah	Hours	X	12-24	20-PM	10	8	4	2	1
	011	0Bh	Days	X	X	20	10	8	4	2	1
	100	0Ch	Weekdays	X	X	X	X	X	4	2	1
	101	0Dh	Months	X	X	X	10	8	4	2	1
	110	0Eh	Years	X	40	20	10	8	4	2	1
Alarm page 00010	000	10h	Second Alarm	AE_S	40	20	10	8	4	2	1
	001	11h	Minute Alarm	AE_M	40	20	10	8	4	2	1
	010	12h	Hour Alarm	AE_H	X	20-PM	10	8	4	2	1
	011	13h	Days Alarm	AE_D	X	20	10	8	4	2	1
	100	14h	Weekday Alarm	AE_W	X	X	X	X	4	2	1
	101	15h	Months Alarm	AE_M	X	X	10	8	4	2	1
	110	16h	Year Alarm	AE_Y	40	20	10	8	4	2	1
Timer page 00011	000	18h	Timer Low	128	64	32	16	8	4	2	1
	001	19h	Timer High	128	64	32	16	8	4	2	1
Temperature page 00100	000	20h	Temperature	128	64	32	16	8	4	2	1
EEPROM User 00101	000	28h	EEPROM User	2 bytes of EEPROM for user data							
	001	29h	EEPROM User								
EEPROM Control page 00110	000	30h	EEPROM Contr.	R80k	R20k	R5k	R1k	FD1	FD0	ThE	ThP
	001	31h	Xtal Offset	sign	64	32	16	8	4	2	1
	010	32h	Xtal Coef	128	64	32	16	8	4	2	1
	011	33h	Xtal T0	X	X	32	16	8	4	2	1
RAM page 00111	000	38h	User RAM	8 bytes of RAM for user data							
	:	:									
	111	3Fh									

Bit positions labelled as "X" are not implemented and will return a "0" when read.

3.2. CONTROL PAGE REGISTER FUNCTION

3.2.1. CONTROL_1 (address 00h...bits description)

Address	Function	Bit 7	Bit 6	Bit 5	Bit 4	Bit 3	Bit 2	Bit 1	Bit 0
00h	Control_1	Clk/Int	TD1	TD0	SROn	EERE	TAR	TE	WE
Bit	Symbol	Value	Description		Reference				
7	Clk/Int	0	Applies $\overline{\text{INT}}$ function on CLKOUT pin		See section 4.9.				
		1	Applies CLKOUT function on CLKOUT pin						
6	TD1	00	Select Source Clock for internal Countdown Timer		See section 4.4.				
		01							
5	TD0	10							
		11							
4	SROn	0	Disables Self Recovery function		See section 4.8.				
		1	Enables Self Recovery function						
3	EERE	0	Disables automatic EEPROM refresh every hour		See section 4.3.				
		1	Enables automatic EEPROM refresh every hour						
2	TAR	0	Disables Countdown Timer auto-reload mode		See section 4.4.				
		1	Enables Countdown Timer auto-reload mode						
1	TE	0	Disables Countdown Timer		See section 4.4.				
		1	Enables Countdown Timer						
0	WE	0	Disables 1Hz Clock Source for Watch		See section 4.7.				
		1	Enables 1Hz Clock Source for Watch						

3.2.2. CONTROL_INT (address 01h...bits description)

Address	Function	Bit 7	Bit 6	Bit 5	Bit 4	Bit 3	Bit 2	Bit 1	Bit 0
01h	Control_INT	X	X	X	SRIE	V2IE	V1IE	TIE	AIE
Bit	Symbol	Value	Description		Reference				
7 to 5	unused	X	Unused						
4	SRIE	0	Disables Self-Recovery INT		See section 4.8.				
		1	Enables Self-Recovery INT						
3	V2IE	0	Disables VLOW2 INT; "Low Voltage 2 detection"		See section 4.1.2.				
		1	Enables VLOW2 INT; "Low Voltage 2 detection"						
2	V1IE	0	Disables VLOW1 INT; "Low Voltage 1detection"		See section 4.1.2.				
		1	Enables VLOW1 INT; "Low Voltage 1detection"						
1	TIE	0	Disables Countdown Timer INT		See section 4.4.1.				
		1	Enables Countdown Timer INT						
0	AIE	0	Disables Alarm INT		See section 4.5.1.				
		1	Enables Alarm INT						

Bit positions labelled as "X" are not implemented and will return a "0" when read.

3.2.3.CONTROL_INT FLAG (address 02h...bits description)

Address	Function	Bit 7	Bit 6	Bit 5	Bit 4	Bit 3	Bit 2	Bit 1	Bit 0
02h	Control_INT Flag	X	X	X	SRF	V2IF	V1IF	TF	AF
Bit	Symbol	Value	Description				Reference		
7 to 5	unused	X	Unused						
4	SRF	0	No Self-Recovery Interrupt generated				See section 4.6.		
		1	Self-Recovery Interrupt generated if possible deadlock is detected; clear flag to clear Interrupt						
3	V2IF	0	No VLOW2 Interrupt generated				See section 4.6.		
		1	VLOW2 Interrupt generated when supply voltage drops below VLOW2 threshold						
2	V1IF	0	No VLOW1 Interrupt generated				See section 4.6.		
		1	VLOW1 Interrupt generated when supply voltage drops below VLOW1 threshold						
1	TF	0	No Timer Interrupt generated				See section 4.6.		
		1	Timer Interrupt generated when Countdown Timer value reaches zero						
0	AF	0	No Alarm Interrupt generated				See section 4.6.		
		1	Alarm Interrupt generated when Time & Date matches Alarm setting						

Bit positions labelled as "X" are not implemented and will return a "0" when read.

3.2.4.CONTROL_STATUS (address 03h...bits description)

Address	Function	Bit 7	Bit 6	Bit 5	Bit 4	Bit 3	Bit 2	Bit 1	Bit 0
03h	Control_Status	EEbusy	X	PON	SR	V2F	V1F	X	X
Bit	Symbol	Value	Description				Reference		
7	EEbusy	0	EEPROM is not busy				See section 4.3.		
		1	Flag is set when EEPROM page is busy due to "write" or automatic EEPROM refresh in progress						
6	unused	X	Unused						
5	PON	0	No Power-On Reset executed				See section 4.1.		
		1	Flag is set at Power-On, flag must be cleared by writing "0"						
4	SR	0	No Self-Recovery Reset or System Reset has been generated.				See section 4.2.1.		
		1	Flag is set when Self-Recovery Reset or System Reset has been generated.						
3	V2F	0	No VLOW2 Interrupt generated"				See section 4.6.		
		1	VLOW2 Interrupt generated when supply voltage drops below VLOW2 threshold						
2	V1F	0	No VLOW1 Interrupt generated"				See section 4.6.		
		1	VLOW1 Interrupt generated when supply voltage drops below VLOW1 threshold						
1 to 0	unused	X	Unused						

Bit positions labelled as "X" are not implemented and will return a "0" when read.

3.2.5.CONTROL_RESET (address 04h...bits description)

Address	Function	Bit 7	Bit 6	Bit 5	Bit 4	Bit 3	Bit 2	Bit 1	Bit 0
04h	Control_Reset	X	X	X	SysR	X	X	X	X
Bit	Symbol	Value	Description				Reference		
7 to 5	unused	X	Unused						
4	SysR	0	No System Reset will be executed				See section 4.2.1.		
		1	Set bit = "1" triggers a System Reset. After the restart of the logic, the SysR will be cleared and in bit 4 "SR" in the register Control_Status will be set						
3 to 0	unused	X	Unused						

Bit positions labelled as "X" are not implemented and will return a "0" when read.

3.3. WATCH PAGE REGISTER FUNCTION

Watch Page registers are coded in the Binary Coded Decimal (BCD) format; BCD format is used to simplify application use.

3.3.1.SECONDS, MINUTES, HOURS, DAYS, WEEKDAYS, MONTHS, YEARS REGISTER

Seconds (address 08h...bits description)

Address	Function	Bit 7	Bit 6	Bit 5	Bit 4	Bit 3	Bit 2	Bit 1	Bit 0
08h	Seconds	X	40	20	10	8	4	2	1
Bit	Symbol	Value	Description						
7	X	-	Unused						
6 to 0	Seconds	0 to 59	This register holds the current seconds coded in BCD format						

Minutes (address 09h...bits description)

Address	Function	Bit 7	Bit 6	Bit 5	Bit 4	Bit 3	Bit 2	Bit 1	Bit 0
09h	Minutes	X	40	20	10	8	4	2	1
Bit	Symbol	Value	Description						
7	X	-	Unused						
6 to 0	Minutes	0 to 59	This register holds the current minutes coded in BCD format						

Hours (address 0Ah...bits description)

Address	Function	Bit 7	Bit 6	Bit 5	Bit 4	Bit 3	Bit 2	Bit 1	Bit 0
0Ah	Hours	X	12-24	20-PM	10	8	4	2	1
Bit	Symbol	Value	Description						
7	X	-	Unused						
12 hour mode (AM/PM)									
6	12-24	0	Selects 24-hour mode						
		1	Selects 12-hour (AM/PM) mode						
5	20-PM	0	Indicates AM						
		1	Indicates PM						
4 to 0	Hours ¹⁾	1 to 12	This register holds the current hours coded in BCD format						
24 hour mode									
6	12-24	0	Selects 24-hour mode						
		1	Selects 12-hour AM/PM mode						
5 to 0	Hours ¹⁾	0 to 23	This register holds the current hours coded in BCD format						

¹⁾ User is requested to pay attention setting valid data only.

**Days (address 0Bh...bits description)**

Address	Function	Bit 7	Bit 6	Bit 5	Bit 4	Bit 3	Bit 2	Bit 1	Bit 0
0Bh	Days	X	X	20	10	8	4	2	1
Bit	Symbol	Value	Description						
7 to 6	X	-	Unused						
5 to 0	Days	1 to 31	This register holds the current days coded in BCD format ¹⁾						

¹⁾ The RTC compensates for leap years by adding a 29th day to February if the year counter contains a value which is exactly divisible by 4; including the year 00.

Weekdays (address 0Ch...bits description)

Address	Function	Bit 7	Bit 6	Bit 5	Bit 4	Bit 3	Bit 2	Bit 1	Bit 0
0Ch	Weekdays	X	X	X	X	X	4	2	1
Bit	Symbol	Value	Description						
7 to 3	X	-	Unused						
2 to 0	Weekdays	1 to 7	This register holds the current weekdays coded in BCD format ¹⁾						

Weekdays ¹⁾	Bit 7	Bit 6	Bit 5	Bit 4	Bit 3	Bit 2	Bit 1	Bit 0
Sunday	X	X	X	X	X	0	0	1
Monday	X	X	X	X	X	0	1	0
Tuesday	X	X	X	X	X	0	1	1
Wednesday	X	X	X	X	X	1	0	0
Thursday	X	X	X	X	X	1	0	1
Friday	X	X	X	X	X	1	1	0
Saturday	X	X	X	X	X	1	1	1

¹⁾ These bits may be re-assigned by the user.

Months (address 0Dh...bits description)

Address	Function	Bit 7	Bit 6	Bit 5	Bit 4	Bit 3	Bit 2	Bit 1	Bit 0
0Dh	Months	X	X	X	10	8	4	2	1
Bit	Symbol	Value	Description						
7 to 5	X	-	Unused						
4 to 0	Months	1 to 12	This register holds the current months coded in BCD format ¹⁾						

Months	Bit 7	Bit 6	Bit 5	Bit 4	Bit 3	Bit 2	Bit 1	Bit 0
January	X	X	X	0	0	0	0	1
February	X	X	X	0	0	0	1	0
March	X	X	X	0	0	0	1	1
April	X	X	X	0	0	1	0	0
May	X	X	X	0	0	1	0	1
June	X	X	X	0	0	1	1	0
July	X	X	X	0	0	1	1	1
August	X	X	X	0	1	0	0	0
September	X	X	X	0	1	0	0	1
October	X	X	X	1	0	0	0	0
November	X	X	X	1	0	0	0	1
December	X	X	X	1	0	0	1	0

¹⁾ The RTC compensates for leap years by adding a 29th day to February if the year counter contains a value which is exactly divisible by 4; including the year 00.

Years (address 0Eh...bits description)

Address	Function	Bit 7	Bit 6	Bit 5	Bit 4	Bit 3	Bit 2	Bit 1	Bit 0
0Eh	Years	X	40	20	10	8	4	2	1
Bit	Symbol	Value	Description						
7	X	-	Unused						
6 to 0	Years	0 to 79	This register holds the current year 20xx coded in BCD format ¹⁾						

¹⁾ The RTC compensates for leap years by adding a 29th day to February if the year counter contains a value which is exactly divisible by 4; including the year 00.

3.3.2.DATA FLOW OF TIME AND DATE FUNCTION

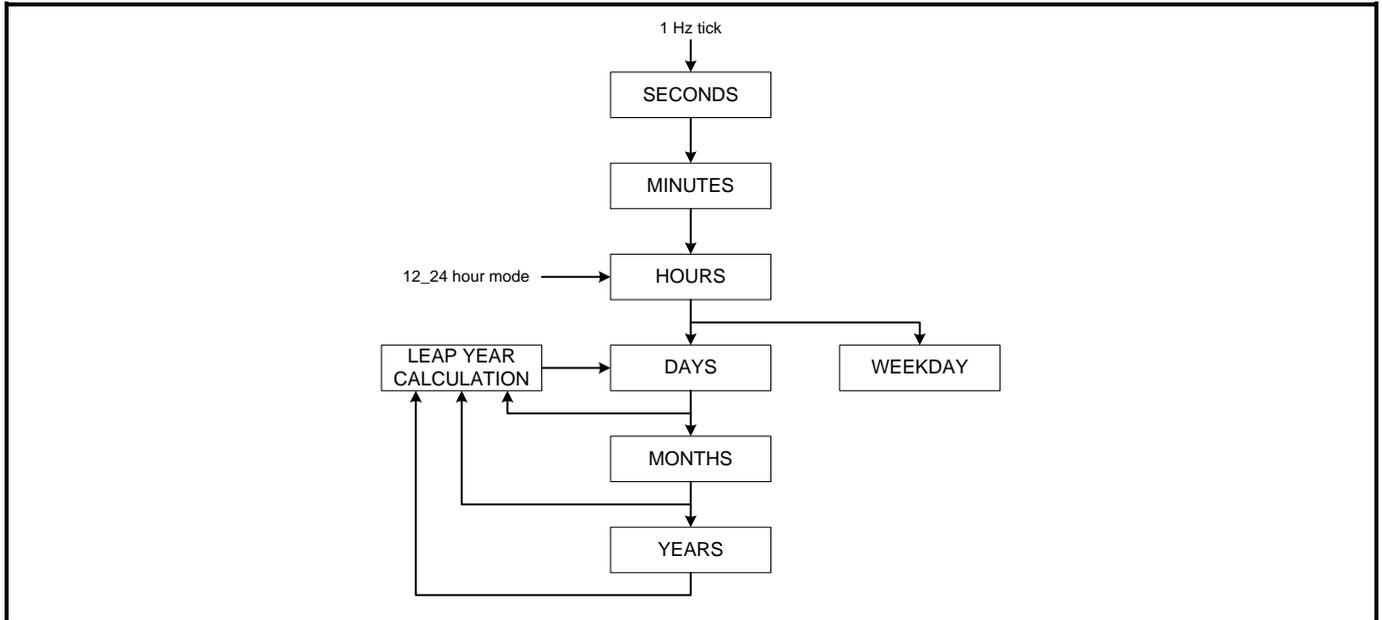

3.4. ALARM PAGE REGISTER FUNCTION

The Alarm Page registers contain alarm information. When one or more of these registers are loaded with a valid second, minute, hour, day, weekday, month or year information and its corresponding alarm enable bit (AE_x) is logic "1", then that information will be compared with the current time / date information in the Watch Page registers.

When all enabled comparisons first match (wired "AND") and the AIE Flag (bit 0 in register Control_INT) is enabled, then the AF Flag (bit 0 in register Control_INT) is set = "1" and an Interrupt signal becomes available at INT pin. Disabled Alarm registers which have their corresponding bit AE_X at logic "0" are ignored.

3.4.1. SECONDS, MINUTES, HOURS, DAYS, WEEKDAYS, MONTHS, YEARS ALARM REGISTER

Alarm Seconds (address 10h...bits description)

Address	Function	Bit 7	Bit 6	Bit 5	Bit 4	Bit 3	Bit 2	Bit 1	Bit 0
10h	Second Alarm	AE_S	40	20	10	8	4	2	1
Bit	Symbol	Value	Description						
7	AE_S	0	Second Alarm is disabled						
		1	Second Alarm is enabled						
6 to 0	Seconds Alarm	0 to 59	These bits hold the Second Alarm information coded in BCD format						

Alarm Minutes (address 11h...bits description)

Address	Function	Bit 7	Bit 6	Bit 5	Bit 4	Bit 3	Bit 2	Bit 1	Bit 0
11h	Minute Alarm	AE_M	40	20	10	8	4	2	1
Bit	Symbol	Value	Description						
7	AE_M	0	Minute Alarm is disabled						
		1	Minute Alarm is enabled						
6 to 0	Minutes Alarm	0 to 59	These bits hold the Minute Alarm information coded in BCD format						

Alarm Hours (address 12h...bits description)

Address	Function	Bit 7	Bit 6	Bit 5	Bit 4	Bit 3	Bit 2	Bit 1	Bit 0
12h	Hours Alarm	AE_H	X	20-PM	10	8	4	2	1
Bit	Symbol	Value	Description						
7	AE_H	0	Hour Alarm is disabled						
		1	Hour Alarm is enabled						
6	X	-	Unused						
12 hour mode (AM/PM)									
5	20-PM	0	Indicates AM						
		1	Indicates PM						
4 to 0	Hours Alarm	1 to 12	These registers hold the Hours Alarm information coded in BCD format when in 12 hour mode						
24 hour mode									
5 to 0	Hours Alarm	0 to 23	These registers hold the Hours Alarm information coded in BCD format when in 24 hour mode						

Alarm Days (address 13h...bits description)

Address	Function	Bit 7	Bit 6	Bit 5	Bit 4	Bit 3	Bit 2	Bit 1	Bit 0
13h	Days Alarm	AE_D	X	20	10	8	4	2	1
Bit	Symbol	Value	Description						
7	AE_D	0	Day Alarm is disabled						
		1	Day Alarm is enabled						
6	X	-	Unused						
5 to 0	Days Alarm	1 to 31	These registers hold the Day Alarm information coded in BCD						

Alarm Weekdays (address 14h...bits description)

Address	Function	Bit 7	Bit 6	Bit 5	Bit 4	Bit 3	Bit 2	Bit 1	Bit 0
14h	Weekday Alarm	AE_W	X	X	X	X	4	2	1
Bit	Symbol	Value	Description						
7	AE_W	0	Weekday Alarm is disabled						
		1	Weekday Alarm is enabled						
6 to 3	X	-	Unused						
2 to 0	Weekday Alarm	1 to 7	These registers hold the Weekday Alarm information coded in BCD						

Alarm Months (address 15h...bits description)

Address	Function	Bit 7	Bit 6	Bit 5	Bit 4	Bit 3	Bit 2	Bit 1	Bit 0
15h	Months Alarm	AE_M	X	X	10	8	4	2	1
Bit	Symbol	Value	Description						
7	AE_M	0	Months Alarm is disabled						
		1	Months Alarm is enabled						
6 to 5	X	-	Unused						
4 to 0	Months Alarm	1 to 12	These registers hold the Months Alarm information coded in BCD						

Alarm Years (address 16h...bits description)

Address	Function	Bit 7	Bit 6	Bit 5	Bit 4	Bit 3	Bit 2	Bit 1	Bit 0
16h	Year Alarm	AE_Y	40	20	10	8	4	2	1
Bit	Symbol	Value	Description						
7	AE_Y	0	Year Alarm is disabled						
		1	Year Alarm is enabled						
6 to 0	Year Alarm	0 to 79	These registers hold the Year Alarm information coded in BCD						

3.5. TIMER PAGE REGISTER FUNCTION

The Timer Page contains 2 registers forming a 16-bit count down timer value.

Countdown Timer Value (addresses 18h / 19h...bits description)

Address	Function	Bit 7	Bit 6	Bit 5	Bit 4	Bit 3	Bit 2	Bit 1	Bit 0
18h	Timer Low	128	64	32	16	8	4	2	1
19h	Timer High	128	64	32	16	8	4	2	1
Address	Symbol	Value	Description						
18h	Timer Low	1 to 255	These bits hold the Low Countdown Timer Value in binary format						
19h	Timer High	0 to 255	These bits hold the High Countdown Timer Value in binary format						

3.6. TEMPERATURE PAGE REGISTER FUNCTION

The Temperature Page register contains the result of the measured temperature ranging from -60°C (=0d) to +190°C (=250d) with 0°C corresponding to a content of =60d.

During read / write access, the content of the register Temperature is frozen in a cache memory to prevent faulty reading.

When the Thermometer is disabled by ThE = "0" (bit 1 in register EEPROM_Control), the register Temperature at address 20h can be externally written.

Temperature Value (address 20h...bits description)

Address	Function	Bit 7	Bit 6	Bit 5	Bit 4	Bit 3	Bit 2	Bit 1	Bit 0
20h	Temperature	128	64	32	16	8	4	2	1
Address	Symbol	Value	Description						
20h	Temperature	-60 to +194°C	These bits hold the Temperature Value coded in binary format						

3.7. EEPROM DATA PAGE REGISTER FUNCTION

The EEPROM Data Page contains 2 non-volatile EEPROM registers for user's application.

Please see section 4.3 EEPROM MEMORY ACCESS for detailed instructions how to handle EEPROM read / write access.

User EEPROM Data Registers (addresses 28h / 29h...bits description)

Address	Function	Bit 7	Bit 6	Bit 5	Bit 4	Bit 3	Bit 2	Bit 1	Bit 0
28h	EEPROM User	128	64	32	16	8	4	2	1
29h	EEPROM User	128	64	32	16	8	4	2	1
Address	Symbol	Value	Description						
28h	EEPROM User	0 to 255	EEPROM User Data (2 Bytes)						
29h	EEPROM User	0 to 255							

3.8. EEPROM CONTROL PAGE REGISTER FUNCTION

The EEPROM Control Page contains 4 non-volatile EEPROM registers.

With Register EEPROM Control, the settings for Trickle-Charger (bit 7-4), the CLKOUT frequency (bit 3&2) and the Thermometer (bit 1&0) can be controlled.

The registers XTAL Offset, XTAL Coef and XTAL T0 contain the factory calibrated, individual crystal parameters to compensate the frequency deviation over the temperature range.

Please see section 4.3 EEPROM MEMORY ACCESS for detailed instructions how to handle EEPROM read / write access.

3.8.1. EEPROM CONTROL (address 30h...bits description)

Address	Function	Bit 7	Bit 6	Bit 5	Bit 4	Bit 3	Bit 2	Bit 1	Bit 0
30h	EEPROM Control	R80k	R20k	R5k	R1k	FD1	FD0	ThE	ThP
Bit	Symbol	Value	Description				Reference		
7	R80k	0	Disables 80 kΩ trickle charge resistor				See section 4.1.		
		1	Enables 80 kΩ trickle charge resistor						
6	R20k	0	Disables 20 kΩ trickle charge resistor						
		1	Enables 20 kΩ trickle charge resistor						
5	R5k	0	Disables 5 kΩ trickle charge resistor						
		1	Enables 5 kΩ trickle charge resistor						
4	R1k	0	Disables 1.5 kΩ trickle charge resistor						
		1	Enables 1.5 kΩ trickle charge resistor						
3	FD1	00	Selects Clock Frequency at CLKOUT pin					See section 4.9.	
2	FD0	01							
		10							
		11							
1	ThE	0	Disables Thermometer				See section 5.2.1.		
		1	Enables Thermometer						
0	ThP	0	Set Temperature Scanning Interval: 1 second				See section 5.2.1.		
		1	Set Temperature Scanning Interval: 16 seconds						

3.8.2. XTAL OFFSET (address 31h...bits description)

Address	Function	Bit 7	Bit 6	Bit 5	Bit 4	Bit 3	Bit 2	Bit 1	Bit 0
31h	XTAL Offset	sign	64	32	16	8	4	2	1
Bit	Symbol	Value	Description				Reference		
7	Sign	0	- Deviation (slower) of 32.768kHz frequency at T ₀				See section 5.2.2.		
		1	+ Deviation (faster) of 32.768kHz frequency at T ₀						
6 to 0	XTAL Offset ¹⁾	0 to 121	Frequency Offset Compensation value						

¹⁾ The XTAL Offset register value is factory programmed according to the crystal's initial frequency-tolerance. For best time-accuracy, the content of this register must not be changed by the user.

3.8.3. XTAL TEMPERATUR COEFFICIENT (address 32h...bits description)

Address	Function	Bit 7	Bit 6	Bit 5	Bit 4	Bit 3	Bit 2	Bit 1	Bit 0
32h	XTAL Coef	128	64	32	16	8	4	2	1
Bit	Symbol	Value	Description				Reference		
7 to 0	XTAL Coef ¹⁾	0 to 255	Quadratic Coefficient of XTAL's Temperature Drift				See section 5.2.2.		

¹⁾ The XTAL Coef register value is factory programmed according to the crystal parameters over temperature. For best time-accuracy, the content of this register must not be changed by the user.

3.8.4.XTAL TURNOVER TEMPERATUR COEFFICIENT T0 (address 33h...bits description)

Address	Function	Bit 7	Bit 6	Bit 5	Bit 4	Bit 3	Bit 2	Bit 1	Bit 0
33h	XTAL T0	x	x	32	16	8	4	2	1
Bit	Symbol	Value	Description					Reference	
7 to 6	x	-	Unused						
5 to 0	XTAL T0 ¹⁾	4 to 67	XTAL's Turnover Temperature in °C					See section 5.2.2.	

¹⁾ The XTAL T0 register value is factory programmed according to the crystal parameters over temperature. For best time-accuracy, the content of this register must not be changed by the user.

3.9. RAM DATA PAGE REGISTER FUNCTION

The RAM Data Page contains 8 RAM registers for user's application.

User RAM Data Registers (addresses 38h to 3Fh...bits description)

Address	Function	Bit 7	Bit 6	Bit 5	Bit 4	Bit 3	Bit 2	Bit 1	Bit 0
38h	RAM User	128	64	32	16	8	4	2	1
---	---	128	64	32	16	8	4	2	1
3Fh	RAM User	128	64	32	16	8	4	2	1
Address	Symbol	Value	Description						
38h	RAM User	0 to 255	RAM User Data (8 Bytes)						
---	---	---							
3Fh	RAM User	0 to 255							

4. DETAILED FUNCTIONAL DESCRIPTION

4.1. POWER-UP, POWER MANAGEMENT AND BATTERY SWITCHOVER

The RV-3049 has two power supply pins:

- V_{DD} the main power supply input pin
- V_{BACKUP} the backup battery input pin

The RV-3049 has multiple power management function implemented:

- Automatic switchover function between main power supply and backup supply voltage. The higher supply voltage is selected automatically, with a switchover hysteresis of 20mV
- Low supply voltage detection V_{Low1} and V_{Low2} with the possibility to generate an \overline{INT} if the corresponding control bits are enabled
- Functions requiring a minimum supply voltage are automatically disabled if low supply voltage is detected
- Interface and CLKOUT are automatically disabled when the device operates in backup supply mode
- Programmable trickle charge circuitry to charge backup battery or supercap

Backup Switchover Circuitry Disables non-used Functions

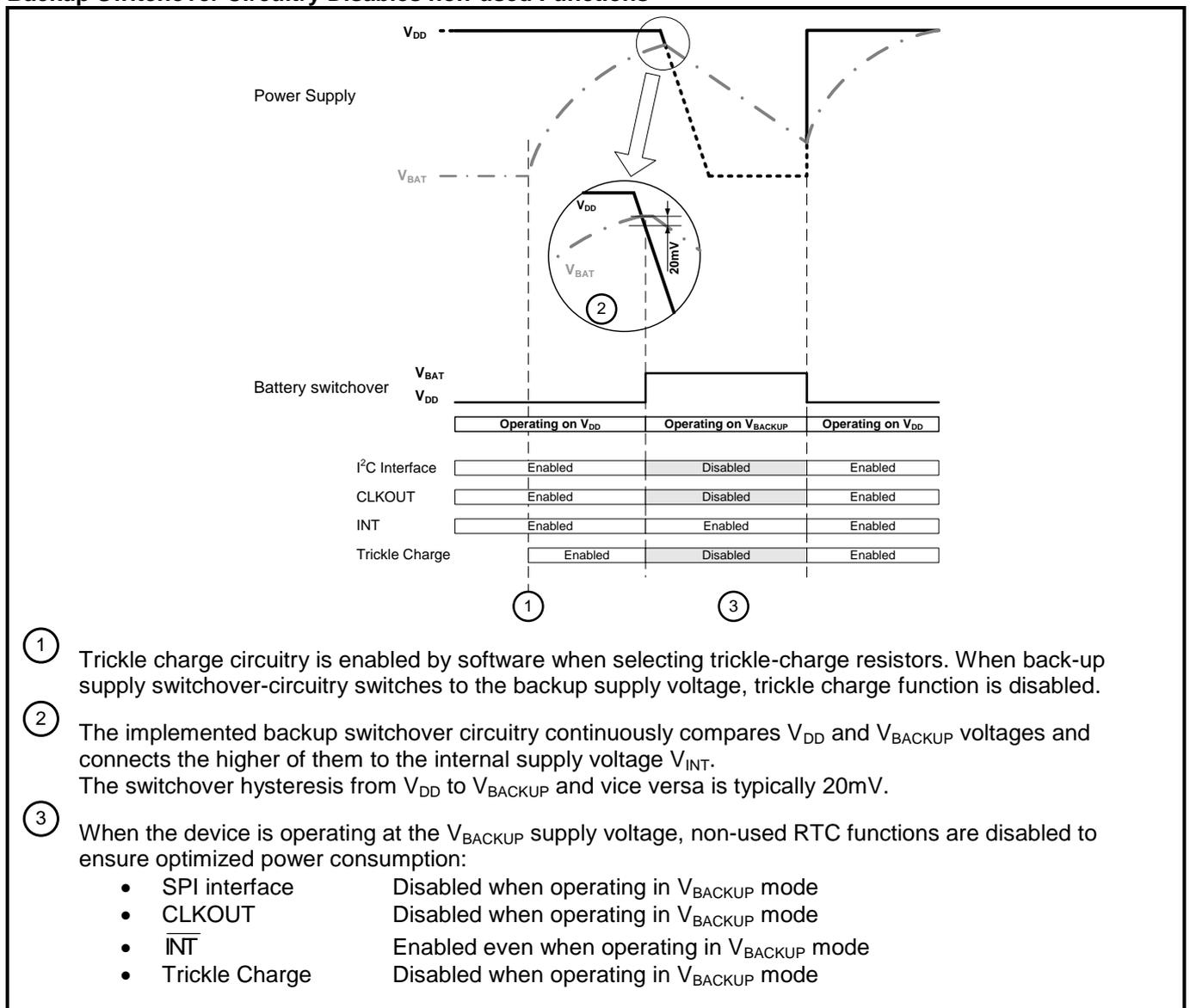

4.1.1. POWER UP SEQUENCE

The device can be either powered up from main supply V_{DD} or from backup supply V_{BACKUP} .

During power-up, the chip is executing the following power-up procedure:

- The implemented battery switchover circuitry compares V_{DD} and V_{BACKUP} voltages and connects the higher of them to supply the chip
- At power-up, the chip is kept in Reset state until the supply voltage reaches an internal threshold level. Once the supply voltage is higher than this threshold level, a Reset is executed and registers are loaded with the Register Reset Values described in section 4.2.2. REGISTER RESET VALUES
- After the Reset is executed and registers are loaded with the Register Reset Values, "PON" is set = "1" (bit 5 in Register Control-Status), it needs to be cleared by writing = "0"
- Once the supply voltage reaches the oscillator start-up voltage, the oscillator-circuitry starts the 32.768 kHz "tuning-fork" Crystal typically within 500 ms
- Once the 32.768 kHz clocks are present, the Voltage Detector starts in fast mode to monitor the supply voltage, the accelerated scanning of the supply voltage will slightly increase the current consumption.
- When a supply voltage $>V_{Low2}$ is detected, the fast mode voltage detection is stopped, and the EEPROM read is enabled
- Configuration registers are loaded with the configuration data read from the EEPROM Control Page and the bits V_{Low1} and V_{Low2} are reset = "0"
- If the Thermometer is enabled by "ThE" = "1" (bit 1 in register EEPROM_Control), the temperature is measured and the frequency compensation value for time correction is calculated
- The RV-3049 becomes fully functional; the correct Time / Date information needs to be loaded into the corresponding registers and bit 5 "PON" in Register Control-Status needs to be cleared by writing "0"

Note 1:

During power up, the Low Voltage Detection is monitoring the supply voltage at an accelerated scan rate increasing the current consumption of the device.

Once power supply voltage exceed V_{Low2} threshold, the flags V_{Low1} and V_{Low2} are cleared and the scan rate for the low voltage detection is set to 1 second to ensure optimized power consumption.

Note 2:

Please not the different meaning of the "PON"; " V_{Low1} " and " V_{Low2} " Flags:

PON

"PON" Flag is set after Power-Up Reset is executed

- Indicating that time & date information are corrupted

V_{Low1}

V_{Low1} Flag is set when supply voltage drops below V_{Low1} threshold

- Indicating that the Thermometer might have been disabled due to low supply voltage and the temperature compensation was operating for a while with the last temperature reading causing bigger time-deviation

V_{Low2}

V_{Low2} Flag is set when supply voltage drops below V_{Low2} threshold

- Indicating a risk that the 32.768 kHz might have stopped due to low supply voltage and that the time & date information might be corrupted

Example Power Up sequence, Low Voltage detection and Backup Supply switchover

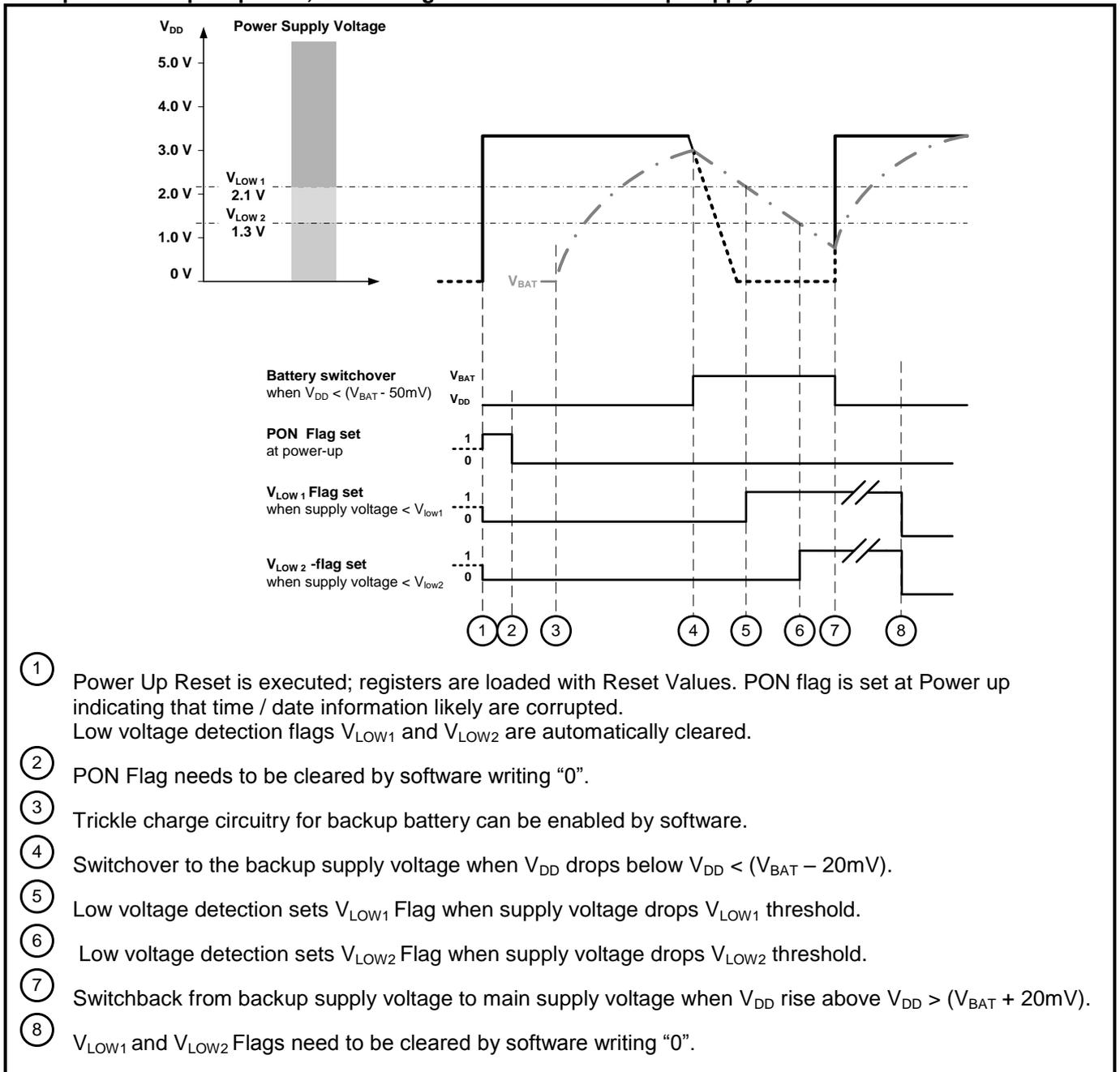

4.1.2.SUPPLY VOLTAGE OPERATING RANGE AND LOW VOLTAGE DETECTION

The RV-3049 has built-in low supply voltage detection which periodically monitors supply voltage levels vs. V_{LOW1} and V_{LOW2} thresholds.

If low supply voltage is detected, the corresponding flags V_{LOW1} and V_{LOW2} are set = "1". Device functions critical to low supply voltage are disabled.

During power up, the Low Voltage Detection is monitoring the supply voltage at an accelerated scan rate. If power supply voltage exceed V_{LOW2} threshold, the flags V_{LOW1} and V_{LOW2} are cleared and the scan rate for the low voltage detection is set to 1 second.

Minimum Supply Voltage and Low Voltage Detection

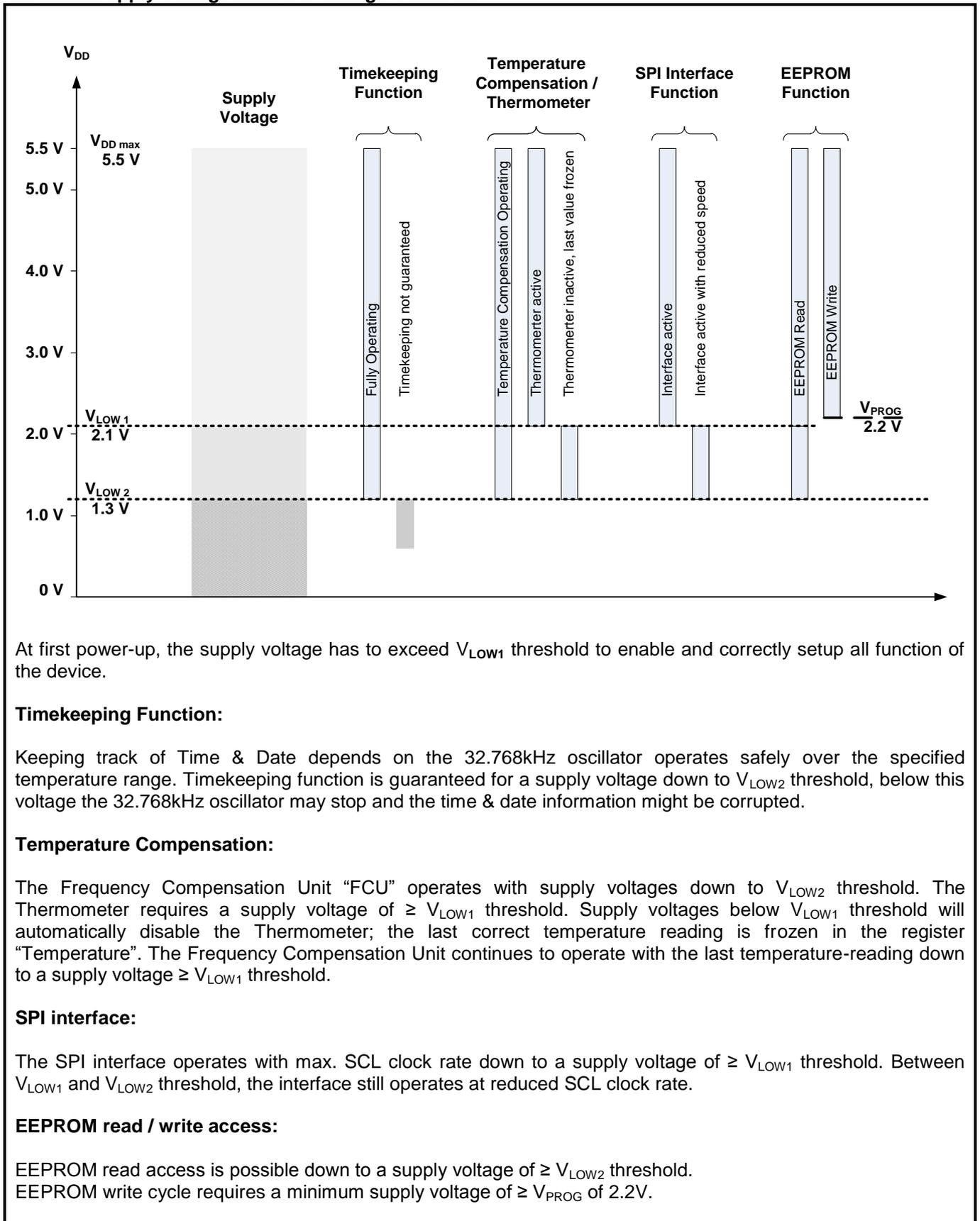

At first power-up, the supply voltage has to exceed V_{LOW1} threshold to enable and correctly setup all function of the device.

Timekeeping Function:

Keeping track of Time & Date depends on the 32.768kHz oscillator operates safely over the specified temperature range. Timekeeping function is guaranteed for a supply voltage down to V_{LOW2} threshold, below this voltage the 32.768kHz oscillator may stop and the time & date information might be corrupted.

Temperature Compensation:

The Frequency Compensation Unit “FCU” operates with supply voltages down to V_{LOW2} threshold. The Thermometer requires a supply voltage of $\geq V_{LOW1}$ threshold. Supply voltages below V_{LOW1} threshold will automatically disable the Thermometer; the last correct temperature reading is frozen in the register “Temperature”. The Frequency Compensation Unit continues to operate with the last temperature-reading down to a supply voltage $\geq V_{LOW1}$ threshold.

SPI interface:

The SPI interface operates with max. SCL clock rate down to a supply voltage of $\geq V_{LOW1}$ threshold. Between V_{LOW1} and V_{LOW2} threshold, the interface still operates at reduced SCL clock rate.

EEPROM read / write access:

EEPROM read access is possible down to a supply voltage of $\geq V_{LOW2}$ threshold. EEPROM write cycle requires a minimum supply voltage of $\geq V_{PROG}$ of 2.2V.

4.2. RESET

A Reset can be initiated by 3 different ways:

- Power On Reset (automatically initiated at power-up)
- Software Reset (can be initiated by software)
- Self-Recovery System Reset (automatically initiated if enabled by Software and possible deadlock is detected)

4.2.1. POWER-UP RESET, SYSTEM RESET AND SELF-RECOVERY RESET

Power On Reset:

A Reset is automatically generated at Power On. After Power On Reset has been executed, bit 5 "PON" in Register Control_Status is set = "1", it needs to be cleared by writing = "0".

System Reset:

A Software Reset can be initiated when the System-Reset command "SysR" is set = "1" (bit 4 in Register Control_Reset). If a System-Reset is executed, the "SR" Flag (bit 4 in Register Control_Status) is set = "1", needs to be cleared by writing = "0".

It is generally recommended to make a System Reset by Software after power-up.

Note:

Please consider the Register Reset Values shown in section 4.2.2. After a Reset has been executed, Self-Recovery System "SROn" (bit 4 in Register Control_1) is set = "1" and Self-Recovery INT Enable "SRIE" (bit 4 in Register Control_INT) is set = "0".

Self-Recovery System Reset:

A Self-Recovery System Reset will be automatically initiated when the Self-Recovery function is enabled by bit 4 "SROn" in Register Control_1 is set "1" and internally a possible deadlock-state is detected. If a Self-Recovery System Reset is executed, the bit 4 "SR" in Register Control_Status is set "1" and need to be cleared by writing "0". After a Self-Recovery System Reset is executed and Register Reset Values were written, bit 4 "SRF" in Register Control_INT Flag is set "1" and needs to be cleared by writing "0".

In case of a Self Recovery System Reset is executed, an Interrupt is available if Self-Recovery-INT function is Enabled by bit 4 "SRIE" in Register Control_INT is set "1".

The purpose of the Self Recovery function is to generate an internal System Reset in case the on-chip state machine goes into a deadlock. The function is based on an internal counter that is periodically reset by the control logic. If the counter is not reset on time, a possible deadlock is detected and a System Reset will be triggered. The System Reset is executed latest after 2 temperature- or voltage-monitoring periods defined in Thermometer Period bit 0 "ThP" in Register EEPROM Control, i.e. latest after 2 or 32 seconds.

Note:

Please consider the Register Reset Values shown in section 4.2.2. After a Reset has been executed, Self-Recovery System bit 4 "SROn" in Register Control_1 = "1" and Self-Recovery INT Enable "SRIE" in Register Control_INT = "0".

4.2.2. REGISTER RESET VALUES

Address			Function	Bit 7	Bit 6	Bit 5	Bit 4	Bit 3	Bit 2	Bit 1	Bit 0
Page	Address	Hex									
Bit 7 - 3		Bit 2 - 0									
Control page 00000	000	00h	Control_1	1	0	0	1	1	0	0	1
	001	01h	Control_INT	-	-	-	0	0	0	0	0
	010	02h	Control_INT Flag	-	-	-	0 ¹⁾	0	0	0	0
	011	03h	Control_Status	EEbusy	X	0 ²⁾	0 ³⁾	X	X	X	X
	100	04h	Control_Reset	-	-	-	0	-	-	-	-
Clock page 00001	000	08h	Seconds	-	X	X	X	X	X	X	X
	001	09h	Minutes	-	X	X	X	X	X	X	X
	010	0Ah	Hours	-	X	X	X	X	X	X	X
	011	0Bh	Days	-	-	X	X	X	X	X	X
	100	0Ch	Weekdays	-	-	-	-	-	X	X	X
	101	0Dh	Months	-	-	-	X	X	X	X	X
	110	0Eh	Years	-	X	X	X	X	X	X	X
Alarm page 00010	000	10h	Second Alarm	AE_S	X	X	X	X	X	X	X
	001	11h	Minute Alarm	AE_M	X	X	X	X	X	X	X
	010	12h	Hour Alarm	AE_H	X	X	X	X	X	X	X
	011	13h	Days Alarm	AE_D	-	X	X	X	X	X	X
	100	14h	Weekday Alarm	AE_W	-	-	-	-	X	X	X
	101	15h	Months Alarm	AE_M	-	-	X	X	X	X	X
	110	16h	Year Alarm	AE_Y	X	X	X	X	X	X	X
Timer page 00011	000	18h	Timer Low	X	X	X	X	X	X	X	X
	001	19h	Timer High	X	X	X	X	X	X	X	X
Temperature page 00100	000	20h	Temperature	X	X	X	X	X	X	X	X
EEPROM User 00101	000	28h	EEPROM User	2 bytes of EEPROM for user data							
	001	29h	EEPROM User								
EEPROM Control page 00110	000	30h	EEPROM Contr.	0 ⁴⁾	0 ⁴⁾	0 ⁴⁾	0 ⁴⁾	0 ⁴⁾	0 ⁴⁾	1 ⁴⁾	0 ⁴⁾
	001	31h	Xtal Offset	Factory setting: Xtal frequency deviation							
	010	32h	Xtal Coef	Factory setting: Xtal temperature coefficient							
	011	33h	Xtal T0	-	-	Factory setting: Xtal T0 temperature					
RAM page 00111	000	38h	User RAM	8 bytes of RAM for user data							
	:	:									
	111	3Fh									

- bits labelled as - are not implemented.

X bits labelled as X are undefined at power-up and unchanged by subsequent resets.

¹⁾ SRF flag (bit 4 in register Control_INT Flag) will be set = "1" after a Self Recovery System Reset was executed.

²⁾ PON flag (bit 5 in register Control_Status) will be set = "1" after a Power On Reset was executed.

³⁾ SR flag (bit 4 in register Control_Status) will be set = "1" after a System or Self recovery Reset was executed.

⁴⁾ EEPROM Control default data are set by factory; data might be reprogrammed by customer and will remain unchanged during power down or any Reset executed.



After Reset, the following mode is entered:

- CLKOUT is selected at CLKOUT pin, default frequency is 32.768 kHz defined in register EEPROM Control
- Timer and Timer Auto-Reload mode are disabled; Timer Source Clock frequency is set to 32Hz
- Self Recovery function is enabled
- Automatic EEPROM Refresh every hour is enabled
- 24 hour mode is selected, no Alarm is set
- All Interrupts are disabled
- At Power-On Reset, "PON" Flag is set = "1" and has to be cleared by writing = "0"
- At Self-Recovery Reset or System Reset, "SR" Flag is set = "1" and has to be cleared by writing = "0".

4.3. EEPROM MEMORY ACCESS

The EEPROM Memory has a built-in automatic EEPROM Refresh function, controlled by “EERE” (bit 3 in register Control_1). If enabled, this function automatically refreshes the content of the EEPROM Memory Pages once an hour.

The “EEbusy” will be set = “1” (bit 7 in register Control_Status) if the EEPROM Memory Pages are busy due to write or automatic refresh cycle is in progress. “EEbusy” goes = “0” when writing is finished, EEPROM Memory Pages shall only be accessed when not busy, i.e. when “EEbusy” = “0”.

A special EEPROM access procedure is required preventing access collision between the internal automatic EEPROM refresh cycle and external read / write access through interface.

- Set “EERE” = “0” Automatic EEPROM Refresh needs to be disabled before EEPROM access.
- Check for “EEbusy” = “0” Access EEPROM only if not busy
- Set “EERE” = “1” It is recommended to enable Automatic EEPROM Refresh at the end of read / write access
- Write EEPROM Allow 10ms wait-time after each written EEPROM register before checking for EEbusy = “0” to allow internal data transfer

Read access:

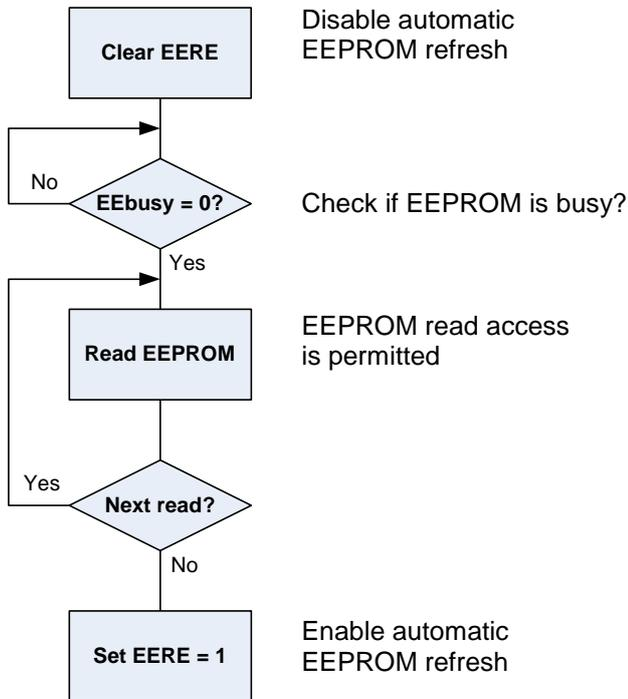

Write access:

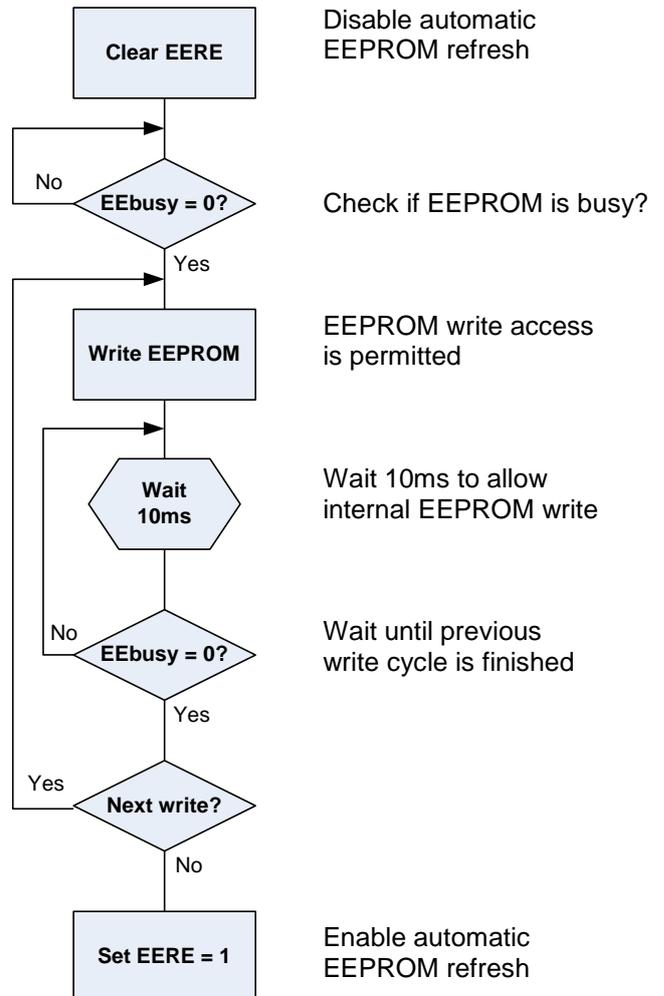

Note:

A minimum power supply voltage of $V_{PROG} = 2.2V$ is required during the whole EEPROM write procedure; i.e. until “EEbusy” = “0”.

4.4. TIMER FUNCTION

The RV-3049 offers different Alarm and Timer functions which allow simply generating highly versatile timing-functions.

The Countdown Timer is controlled by the register Control_1. Bit 1 "TE" enables the Timer function; bits 5 & 6 "TD0" and "TD1" determine one of 4 Timer Source Clock frequencies (32 Hz, 8 Hz, 1 Hz, or 0.5Hz).

The Timer counts down from a software-loaded 16-bit binary value ,n', "Timer Low" (bit 0-7 at address 18h) and "Timer High" (bit 0-7 at address 19h). Values, n' from 1 to 65536 are valid; loading the counter with ,n' = "0" effectively stops the timer. The end of every Timer countdown is achieved when the Timer Counter value ,n' reaches = "0".

Countdown Timer can be set in Automatic Reload mode by "TAR" = "1" (bit 2 of register Control_1), the counter automatically re-loads Timer countdown value, n' and starts the next Timer period. Automatic reload of the countdown value ,n' requires 1 additional timer source clock. This additional timer source clock has no effect on the first Timer period, but it has to be taken into account since it results in a Timer duration of ,n+1' for subsequent timer periods.

The generation of Interrupts from the Countdown Timer function is enabled by "TIE" = "1" (bit 1 in register Control_INT). If Timer Interrupt is enabled by "TIE" = "1", the Timer Flag "TF" (bit 1 in register Control_INT Flag) will be set = "1" at the end of every Timer countdown. The Interrupt signal \overline{INT} follows the condition of Timer Flag "TF" (bit 1 in register Control_INT Flag), the \overline{INT} signal can be cleared by clearing the "TF" = "0".

Control of the Countdown Timer Functions (address 00h...bits description)

Address	Function	Bit 7	Bit 6	Bit 5	Bit 4	Bit 3	Bit 2	Bit 1	Bit 0
00h	Control_1	Clk/Int	TD1	TD0	SROn	EERE	TAR	TE	WE
Bit	Symbol	Value	Description						
6	TD1	00	Timer Source Clock Frequency: 32 Hz						
		01	Timer Source Clock Frequency: 8 Hz						
5	TD0	10	Timer Source Clock Frequency: 1 Hz						
		11	Timer Source Clock Frequency : 0.5 Hz						
2	TAR	0	Disables Countdown Timer Auto-Reload mode						
		1	Enables Countdown Timer Auto-Reload mode						
1	TE	0	Disables Countdown Timer						
		1	Enables Countdown Timer						

The Timer Source Clock Frequency "TD0" & "TD1" and the Timer Auto Reload mode "TAR" can only be written when the Timer is stopped by "TE" = "0" (bit 1 in register Control_1).

The Countdown Timer values in "Timer Low" and "Timer High" can only be written when the Timer is stopped by "TE" = "0" and Timer Auto Reload mode is disabled "TAR" = "0".

Register Countdown Timer (addresses 18h / 19h...bits description)

Register 18h is loaded with the low byte of the 16-bit Countdown Timer value ,n'

Register 19h is loaded with the high byte of the 16-bit Countdown Timer value ,n'

Address	Function	Bit 7	Bit 6	Bit 5	Bit 4	Bit 3	Bit 2	Bit 1	Bit 0
18h	Timer Low	128	64	32	16	8	4	2	1
19h	Timer High	128	64	32	16	8	4	2	1
Bit	Symbol	Value	Description						
18h	Timer Low	xx01 to xxFF	Countdown value = n Countdown period = $\frac{n}{\text{Source Clock Frequency}}$						
19h	Timer High	00xx to FFxx							

Example Countdown Timer function with Timer in Auto Reload mode

In this example, the Countdown Timer is set to Automatic Reload Mode, the Countdown Timer value is set = “3”. Automatic reload of the countdown value ,n’ requires 1 additional Timer Source Clock. This additional timer source clock has no effect on the first Timer period but it has to be taken into account since it results in a Timer duration of ,n+1’ for subsequent timer periods. The Interrupt signal (\overline{INT}) is cleared by clearing the Timer Flag “TF” = “0”.

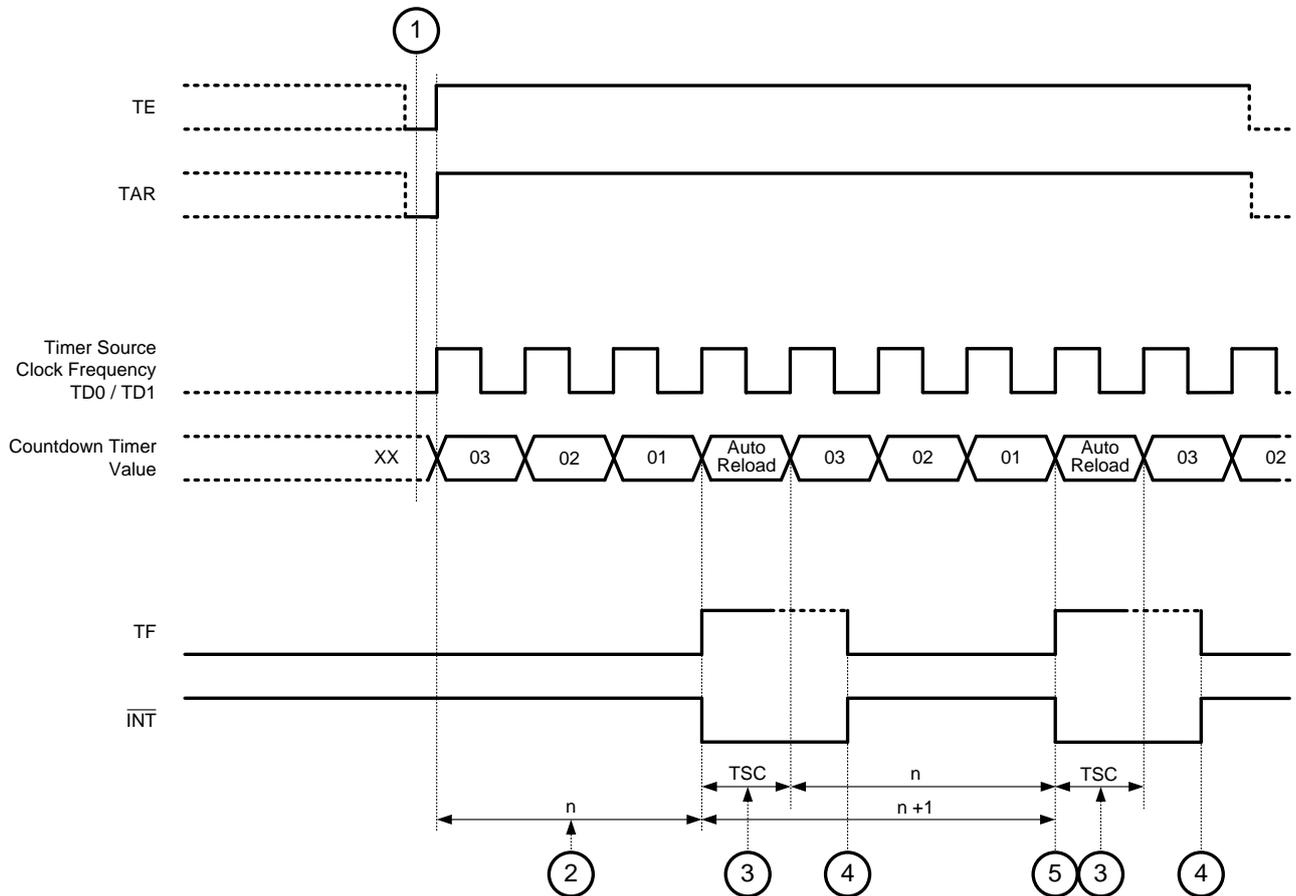

- ① Timer Source Clock Frequency TD0 / TD1 can only be modified when Timer is disabled “TE” = “0” Countdown Timer value ,n’ in “Timer Low” and “Timer High” only can be modified when Timer “TE” = “0” and Timer Auto Reload “TAR” = “0” are both disabled.
- ② Duration of first Timer Period = $\frac{n}{\text{Source Clock Frequency}}$
The additional timer source clock for automatic reload of the countdown Timer value ,n’ has no effect on the first Timer Period.
- ③ Timer Automatic Reload mode “TAR” requires one Timer Source Clock period for automatic reload of the Countdown Timer value ,n’.
- ④ To reset Interrupt signal (\overline{INT}), Timer Flag “TF” has to be cleared by writing = “0”.
- ⑤ When Countdown Timer is in automatic reload mode, one additional timer source clock has to be taken into account since it results in a Timer duration of ,n+1’ for subsequent timer periods.



4.4.1.TIMER INTERRUPT

The generation of Interrupts from the Countdown Timer function is enabled by "TIE" = "1" (bit 1 in register Control_INT). If Timer Interrupt is enabled by "TIE" = "1", the Timer Flag "TF" (bit 1 in register Control_INT Flag) will be set = "1" at the end of every Timer countdown.

The Interrupt signal INT follows the condition of Timer Flag "TF" (bit 1 in register Control_INT Flag), the Timer Flag "TF" and the Interrupt signal (INT) remain set until cleared by software writing "TF" = "0".

Timer Interrupt Control (addresses 01h / 02h...bits description)

Address	Function	Bit 7	Bit 6	Bit 5	Bit 4	Bit 3	Bit 2	Bit 1	Bit 0	
01h	Control_INT	X	X	X	SRIE	V2IE	V1IE	TIE	AIE	
bit 1	TIE	0	TF is disabled, no Timer Interrupt generated							
		1	TF is enabled, Timer Interrupt generated when Countdown Timer value reaches zero and TF is set "1"							
02h	Control_INT Flag	X	X	X	SRF	V2IF	V1IF	TF	AF	
bit 1	TF	0	No Timer Interrupt generated							
		1	Timer Flag is set "1" when TIE is enabled and Countdown Timer value reaches zero, TF needs to be cleared to clear INT							

Bit positions labelled as "X" are not implemented and will return a "0" when read.

4.5. ALARM FUNCTION

Every Alarm Register in Alarm Page can be individually enabled by setting bit 7 (AE_x) = "1". Disabled alarm registers which have their bit "AE_x" at logic = "0" are ignored.

When one or more of these registers are loaded with a valid second, minute, hour, day, weekday, month or year information and its corresponding alarm enable bit (AE_x) is logic = "1", then that information will be compared with the current time / date information in Watch Page registers.

Alarm function Blockdiagram

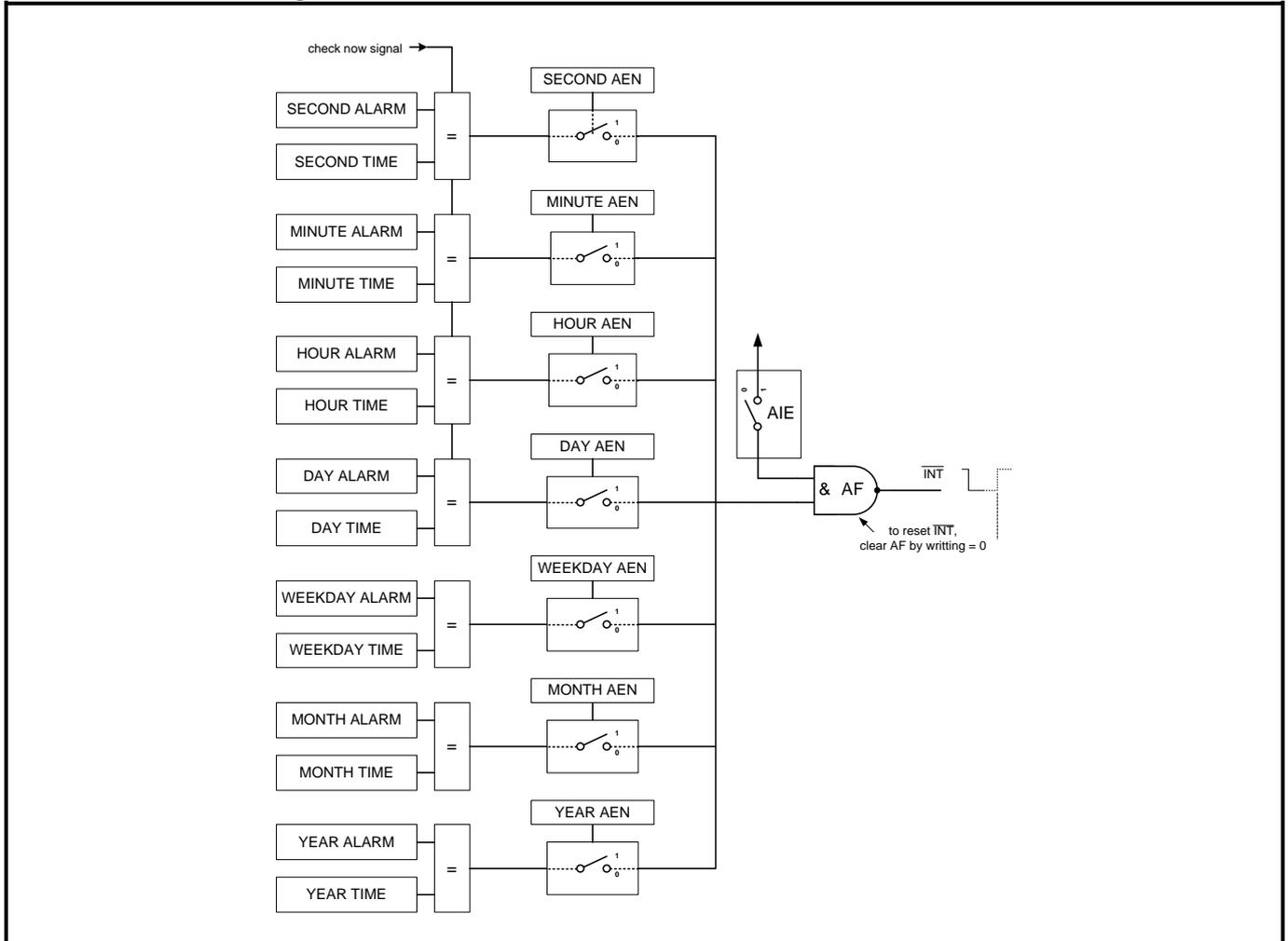

4.5.1.ALARM INTERRUPT

The generation of Interrupts from the Alarm function is enabled by “AIE” = “1” (bit 0 in register Control_INT).

When all enabled Alarm comparisons first match (wired “AND”) and the Alarm Interrupt is enabled by, the Alarm Flag “AF” (bit 0 in Register Control_INT Flag) is set to logic = “1”. The Interrupt signal (\overline{INT}) follows the condition of “AF”.

The Interrupt signal \overline{INT} follows the condition of Alarm Flag “AF” (bit 0 in register Control_INT Flag), The Alarm Flag “AF” and the Interrupt signal (\overline{INT}) remain set until cleared by software writing “AF” = “0”.

Once bit “AF” has been cleared, it will only be set again when the time increments and matches the alarm condition once more.

Alarm Interrupt Control (addresses 01h / 02h...bits description)

Address	Function	Bit 7	Bit 6	Bit 5	Bit 4	Bit 3	Bit 2	Bit 1	Bit 0	
01h	Control_INT	X	X	X	SRIE	V2IE	V1IE	TIE	AIE	
0	AIE	0	AF is disabled, no Alarm Interrupt generated							
		1	AF is enabled, AF is set “1”and Alarm Interrupt generated when all enabled Alarm comparisons first match							
02h	Control_INT Flag	X	X	X	SRF	V2IF	V1IF	TF	AF	
0	AF	0	No Alarm Interrupt generated							
		1	Alarm Flag is set “1” when all enabled Alarm comparisons first match, needs to be cleared to clear \overline{INT}							

Bit positions labelled as “X” are not implemented and will return a “0” when read.

Example for Alarm Flag and Alarm INT

Example where “Minute Alarm” is enabled and set to 45 and no other Alarm is enabled.

If bit AIE is enabled, the \overline{INT} pin follows the condition of bit 0 “AF” in register Control_INT Flag at address 02h.

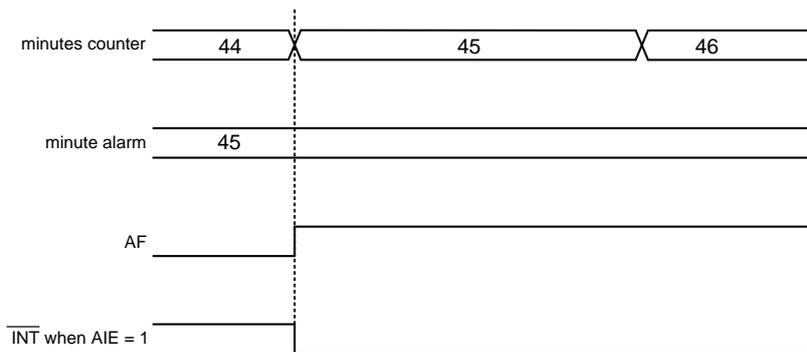

4.6. INTERRUPT OUTPUT INT

An active LOW Interrupt signal is available at $\overline{\text{INT}}$ pin.

The $\overline{\text{INT}}$ is an open-drain output and requires a pull-up resistor to V_{DD} .

Interrupts may be sourced from five places:

- Alarm function
- Countdown Timer function
- V_{LOW1} detection
- V_{LOW2} detection
- System Reset function

All Interrupt signals follow the condition of their corresponding flags in the bits 0 to 4 of register Control_INT Flag at address 02h.

Alarm Interrupt:

Generation of Interrupts from the Alarm function is enabled via "AIE" = "1" (bit 0 in register Control_INT). If "AIE" is enabled, the $\overline{\text{INT}}$ pin follows the condition of Flag "AF" (bit 0 in register Control_INT Flag). To clear Interrupt signal ($\overline{\text{INT}}$), the corresponding flag "AF" needs to be cleared by writing = "0", clearing "AF" will immediately clear $\overline{\text{INT}}$.

Timer Interrupt:

Generation of Interrupts from the Countdown Timer is enabled via "TIE" = "1" (bit 1 in register Control_INT). If "TIE" is enabled, the $\overline{\text{INT}}$ pin follows the condition of Flag "TF" (bit 1 in register Control_INT Flag). To clear Interrupt signal ($\overline{\text{INT}}$), the corresponding flag "TF" needs to be cleared by writing = "0", clearing "TF" will immediately clear $\overline{\text{INT}}$.

V_{LOW1} Interrupt:

Generation of Interrupts from the Voltage Low 1 detection is enabled via "V1IE" = "1" (bit 2 in register Control_INT). If "V1IE" is enabled, the $\overline{\text{INT}}$ pin follows the condition of Flag "V1IF" (bit 2 in register Control_INT Flag). To clear Interrupt signal ($\overline{\text{INT}}$), both corresponding flags "V1IF" (bit 2 in register Control_INT Flag) and "V1F" (bit 2 in register Control_Status) need to be cleared by writing = "0".

V_{LOW2} Interrupt:

Generation of Interrupts from the Voltage Low 2 detection is enabled via "V2IE" = "1" (bit 3 in register Control_INT). If "V2IE" is enabled, the $\overline{\text{INT}}$ pin follows the condition of Flag "V2IF" (bit 3 in register Control_INT Flag). To clear Interrupt signal ($\overline{\text{INT}}$), both corresponding flags "V2IF" (bit 3 in register Control_INT Flag) and "V2F" (bit 3 in register Control_Status) need to be cleared by writing = "0".

System Reset Interrupt:

Generation of Interrupts from the System Reset function is enabled via "SRIE" = "1" (bit 4 in register Control_INT). If "SRIE" is enabled, the $\overline{\text{INT}}$ pin follows the condition of Flag "SRF" (bit 4 in register Control_INT Flag). To clear Interrupt signal ($\overline{\text{INT}}$), both corresponding flags "SRF" (bit 4 in register Control_INT Flag) and "SR" (bit 4 in register Control_Status) need to be cleared by writing = "0".



4.7. WATCH ENABLE FUNCTION

The function Watch Enable function “WE” (bit 0 in register Control_1) enables / disables the 1 Hz clock for the watch function. After power-up reset, the bit “WE” is automatically set = “1” and the 1 Hz clock is enabled. Setting “WE” = “0” stops the watch-function and the time circuits can be set and will not increment until the stop is released. Setting “WE” = “1” allows for accurate start of the time circuits triggered by an external event.

“WE” will not affect the clock outputs at CLKOUT.

4.8. SELF-RECOVERY SYSTEM

The purpose of the Self-Recovery System is to automatically generate an internal Reset in case the on-chip state machine goes into a deadlock. A possible source for such a deadlock could be disturbed electrical environment like EMC problem, disturbed power supply or any kind of communication issues on the SPI interface.

The function of the Self-Recovery System is based on internal counter that is periodically reset by the Control Logic. If the counter is not reset in time, a Self-Recovery Reset will be executed, at the latest after 2 thermometer scanning interval periods, i.e. 2 or 32 seconds.

The Self-Recovery System is enabled / disabled by “SROn” (bit 4 in register Control_1), it is automatically enabled “SROn” = “1” after power-up by the register reset values, see section 4.2.2. REGISTER RESET VALUES. Thermometer scanning interval is defined with “ThP” (bit 0 in register EEPROM_Control).

Generation of Interrupts from the System Reset function is enabled via “SRIE” = “1” (bit 4 in register Control_INT). If “SRIE” is enabled, the \overline{INT} follows the condition of Flag “SRF” (bit 4 in register Control_INT Flag). To clear Interrupt signal (\overline{INT}), both corresponding flags “SRF” (bit 4 in register Control_INT Flag) and “SR” (bit 4 in register Control_Status) need to be cleared by writing = “0”.

During Self-Recovery or System Reset, the internal logic is reset and registers are loaded with the Register Reset Values shown in section 4.2.2., Watch / Alarm and Timer information are not affected.

After Self-Recovery Reset, “SRF” is set = “1” (bit 4 in Register Control_INT Flag), indicating that an automatic Self-Recovery System Reset has been executed.

4.9. CLOCK OUTPUT CLKOUT

The internal reference frequency is generated by the oscillator-circuitry operating a 32.768 kHz “Tuning-Fork” Quartz Crystal.

A programmable square wave is available at CLKOUT pin. Frequencies of 32.768 kHz, 1024 Hz, 32 Hz or 1 Hz can be generated for use as a system clock, microcontroller clock, input to a charge pump or for test purposes.

The duty cycle of the selected clock is not controlled. However, due to the nature of the clock generation, all frequencies will be 50:50 except the 32.768 kHz.

The frequency 32.768 kHz is clocked directly from the oscillator-circuitry, as a consequence of that, this frequency does not contain frequency compensation clock pulses. The frequencies 1024 / 32 / 1 Hz are clocked from the prescaler and contain frequency compensation clock pulses.

Operation is controlled by the bits “FD1” / “FD0” (bit 2 & 3 in the register EEPROM Control).

If “Clk/Int” is = “1” (bit 7 in register Control_1), CLKOUT pin becomes a push-pull CLKOUT output and can be enabled / disabled with the CLKOE pin. When disabled with CLKOE pin = “low”, the CLKOUT output is pulled low.

Register EEPROM Control FD0 / FD1 CLKOUT Frequency Selection (address 30Eh...bits description)

Address	Function	Bit 7	Bit 6	Bit 5	Bit 4	Bit 3	Bit 2	Bit 1	Bit 0
30h	EEPROM Control	R80k	R20k	R5k	R1k	FD1	FD0	ThE	1
Bit	3	2	CLKOUT Frequency [Hz]	Typ. Duty Cycle % ¹⁾	Remarks				
	FD1	FD0							
3 to 2	0	0	32768	40:60 to 60:40	Directly from 32.768kHz oscillator circuitry, without freq. compensation				
	0	1	1024	50:50	With frequency compensation				
	1	0	32	50:50	With frequency compensation				
	1	1	1	50:50	With frequency compensation				

¹⁾ Duty cycle definition: % HIGH-level time : % LOW-level time

5. COMPENSATION OF FREQUENCY DEVIATION AND FREQUENCY DRIFT vs TEMPERATURE

There is a Thermometer and a Frequency Compensation Unit “FCU” built-in the RV-3049.

Based on all known tolerances and the measured ambient temperature, this Frequency Compensation Unit “FCU” is calculating every 32 seconds a Frequency Compensation Value. The frequency compensation itself is achieved by adding or subtracting clock-pulses to the 32.768 kHz reference clock, one compensation period takes 32 seconds.

All required parameters for frequency compensation are factory calibrated and should not be modified to profit from best time accuracy.

Frequency deviations affecting the time accuracy of Real Time Clocks:

- XTAL offset: Xtal’s frequency deviation ± 20 ppm @ 25°C
- XTAL T_0 : Xtal’s turnover temperature 25°C ± 5 °C
- XTAL temp. coefficient: Xtal’s frequency drift vs temperature -0.035 ppm * $(T-T_0)^2 \pm 10\%$

5.1. TEMPERATURE CHARACTERISTICS TUNING FORK CRYSTAL

Typical Frequency Deviation of a 32.768 kHz Tuning Fork Crystal over Temperature

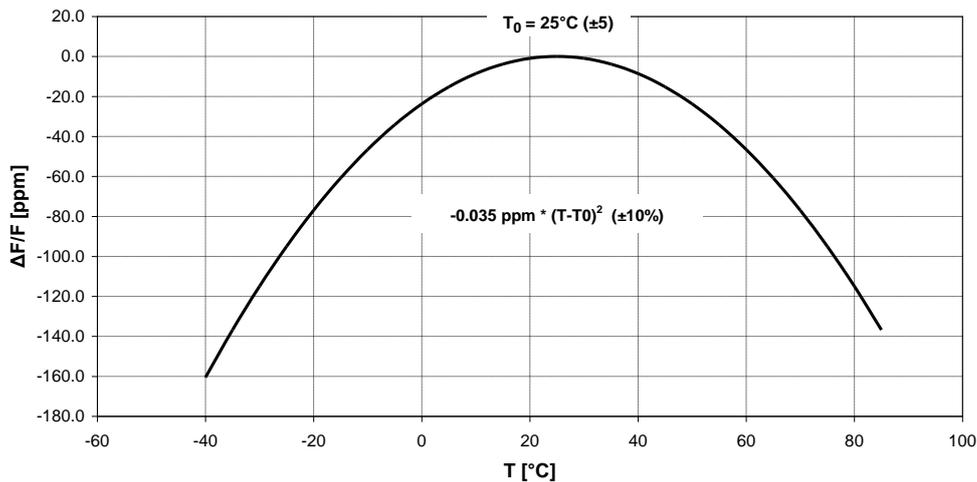

Above graph shows the typical frequency-deviation of a 32.768kHz “Tuning-Fork” Crystal over temperature. The parabolic curve is specified in terms of turnover temperature “ T_0 ” and the quadratic thermal coefficient “ β ”.

- T_0 : turnover temperature 25°C ± 5 °C
- B: 2nd order temperature coefficient -0.035 ppm * $(T-T_0)^2 \pm 10\%$ (quadratic thermal coefficient)

5.2. COMPENSATION PRINCIPLE

The Frequency Compensation Unit “FCU” is calculating every 32 seconds a Frequency Compensation Value based on individual device data:

- XTAL offset: Device individual frequency deviation $\pm 20\text{ppm}$ @ 25°C
- XTAL T_0 : Xtal's turnover temperature $25^\circ\text{C} \pm 5^\circ\text{C}$
- XTAL temp. coefficient: Xtal's frequency drift vs. temperature $-0.035 \text{ ppm} * (T-T_0)^2 \pm 10\%$
- Temperature: Measured ambient temperature

Calculating the Anticipated Frequency Deviation and the Time Compensation Value

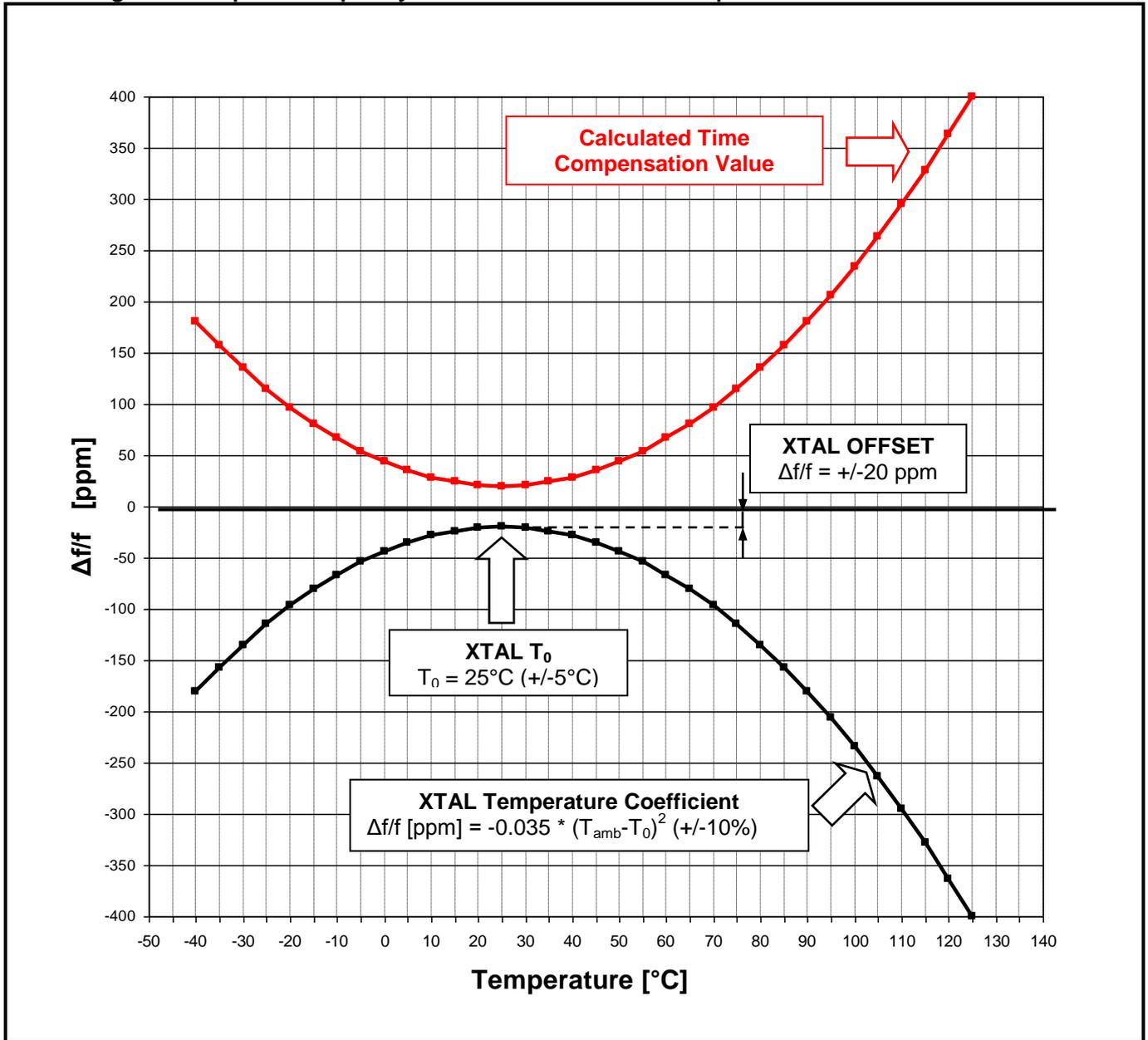

Note:

The 32.768 kHz frequency is adjusted according to the calculated Time Compensation value. The compensation itself is achieved by adding or subtracting clock-pulses to the 32.768 kHz reference clock. One complete compensation period takes 32 seconds.

5.2.1.THERMOMETER AND TEMPERATURE VALUE

The function of the Thermometer is controlled by “ThP” and “ThE” (bit 0 & bit 1 in the register EEPROM Control).

Register EEPROM Control Thermometer Control (address 30h...bits description)

Address	Function	Bit 7	Bit 6	Bit 5	Bit 4	Bit 3	Bit 2	Bit 1	Bit 0
30h	EEPROM Control	R80k	R20k	R5k	R1k	FD1	FD0	ThE	ThP
Bit	Symbol	Value	Description						
1	ThE	0	Disable Thermometer						
		1	Enable Thermometer						
0	ThP	0	Thermometer scanning interval: 1 second						
		1	Thermometer scanning interval: 16 seconds						

The measured temperature value is stored in the register “Temperature” at address 20h. The measured temperature is binary coded ranging from -60°C (=0d) to +190°C (=250d). Example: Temperature of 0°C corresponding to a content of = 60d.

The thermometer has a resolution of 1°C per LSB; the typical accuracy is +/-4°C within the temperature range -40°C to +125°C. The Thermometer is automatically disabled if status bit “Vlow1” is set = “1”, the result of the last temperature measurement is frozen in register “Temperature” and the frequency compensation continues working with this last temperature reading.

The actual temperature value can be read from register “Temperature” at address 20h. The Thermometer has to be disabled by ThE = “0” to externally write a temperature value into the register “Temperature” at address 20h.

Temperature Value (address 20h...bits description)

Address	Function	Bit 7	Bit 6	Bit 5	Bit 4	Bit 3	Bit 2	Bit 1	Bit 0
20h	Temperature	128	64	32	16	8	4	2	1
		These bits hold the Temperature Value coded in binary format							
Temperature	Value hex	Bit 7	Bit 6	Bit 5	Bit 4	Bit 3	Bit 2	Bit 1	Bit 0
-60°C	00h	0	0	0	0	0	0	0	0
-59°C	01h	0	0	0	0	0	0	0	1
0°C	3Ch	0	0	1	1	1	1	0	0
194°C	FEh	1	1	1	1	1	1	1	0
195°C	FFh	1	1	1	1	1	1	1	1

5.2.2.SETTING THE FREQUENCY COMPENSATION PARAMETERS

In order to achieve best time accuracy, correct parameters have to be stored into the corresponding registers of the EEPROM Control page.

Attention: these parameters are factory calibrated, it is recommended not to modify these register values.

XTAL Offset (address 31h...bits description)

Address	Function	Bit 7	Bit 6	Bit 5	Bit 4	Bit 3	Bit 2	Bit 1	Bit 0
31h	XTAL Offset	sign	64	32	16	8	4	2	1
Bit	Symbol	Value	Description						
7	Sign	0	- Deviation (slower) of 32.768kHz frequency at T ₀						
		1	+ Deviation (faster) of 32.768kHz frequency at T ₀						
6 to 0	XTAL Offset	0 to 121	Frequency Offset Compensation value						

The register value “XTAL Offset” is used by the Frequency Compensation Unit “FCU” to compensate the initial frequency deviation of the 32.768 kHz clock at the crystal’s turnover temperature “XTAL T₀”.

The required register value “XTAL Offset” is calculated as follow:

$$\text{XTAL Offset} = \text{Xtal}_{\text{OFFSET}} \times 1.05$$

XTAL COEF Temperature Coefficient (address 32h...bits description)

Address	Function	Bit 7	Bit 6	Bit 5	Bit 4	Bit 3	Bit 2	Bit 1	Bit 0
32h	XTAL Coef	128	64	32	16	8	4	2	1
Bit	Symbol	Value	Description						Reference
7 to 0	XTAL Coef ¹⁾	0 to 255	Quadratic Coefficient of XTAL's Temperature Drift						

¹⁾ The factory programmed register value XTAL Coef may also contain thermometer error compensation.

The register value “XTAL Coef” is used by the Frequency Compensation Unit “FCU” to compensate the frequency deviation caused by 2nd order temperature coefficient of the 32.768 kHz crystal (frequency drift vs temperature).

The required register value “XTAL Coef” is calculated as follow:

$$\text{XTAL Coef} = \text{Xtal}_{\text{TEMPERATURE COEFFICIENT}} \times 4096 \times 1.05$$

XTAL T0 Turnover Temperature (address 33h...bits description)

Address	Function	Bit 7	Bit 6	Bit 5	Bit 4	Bit 3	Bit 2	Bit 1	Bit 0
33h	XTAL T0	x	x	32	16	8	4	2	1
Bit	Symbol	Value	Description						Reference
7 to 6	x	-	unused						
5 to 0	XTAL T0 ¹⁾	4 to 67	XTAL's Turnover Temperature in °C						

¹⁾ The factory programmed register value XTAL T₀ may also contain thermometer error compensation.

The register value “XTAL T0” is used by the Frequency Compensation Unit “FCU” to compensate the frequency deviation caused by the turnover temperature T0 of the 32.768 kHz crystal.

The required register value “XTAL T0” is calculated as follow:

$$\text{XTAL T0} = \text{Xtal}_{\text{TURNOVER TEMP T0}} - 4$$

5.3. METHOD OF COMPENSATING THE FREQUENCY DEVIATION

The Frequency Compensation Unit (FCU) calculates every 32 seconds the compensation factor needed to obtain accurate time information. The compensation is made by adding or subtracting correction clocks to the 32.768 kHz reference frequency at the first stage of the frequency divider chain, thereby changing the period of a single second.

Extra clocks are added for to speed-up the timing, subtracting clocks to slow-down the timing.

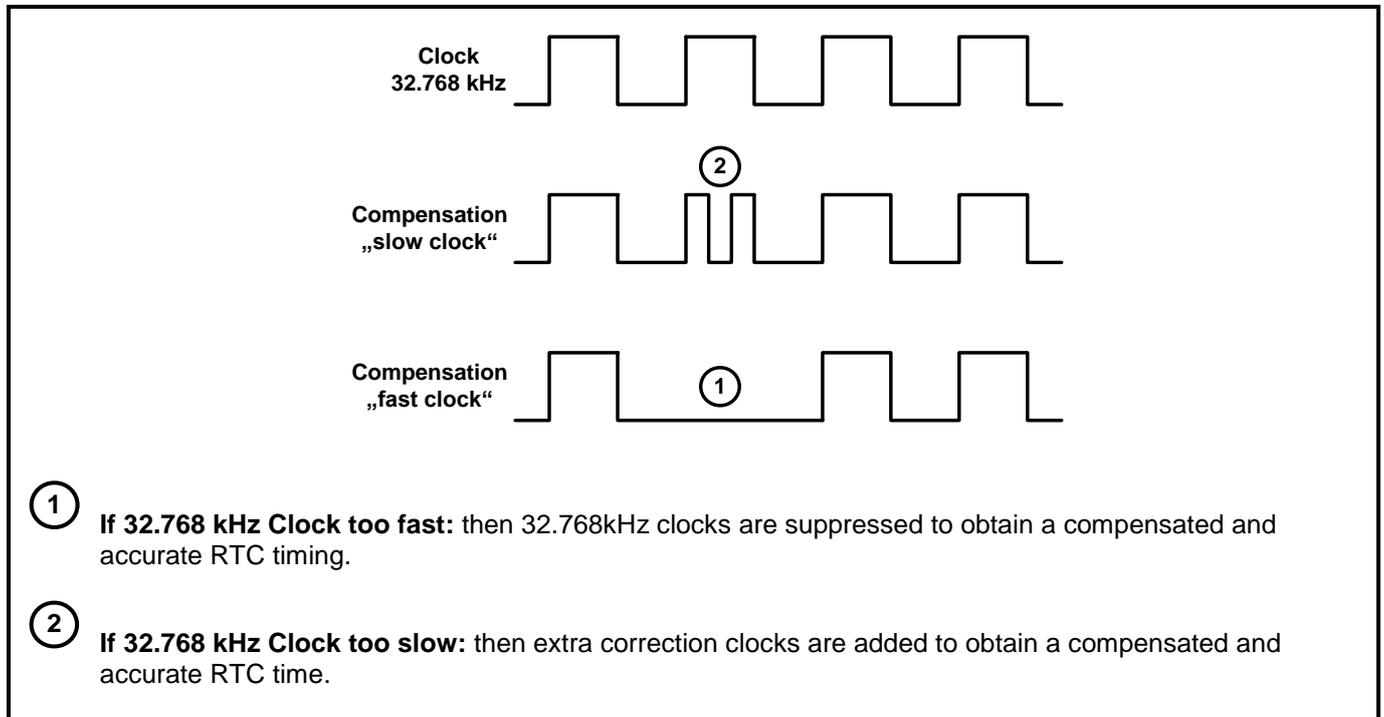

Each compensation period takes 32 seconds. Correction clocks are periodically applied during one complete compensation period. Within a compensation period of 32 seconds, one correction clock will compensate the time information by ± 1 ppm.

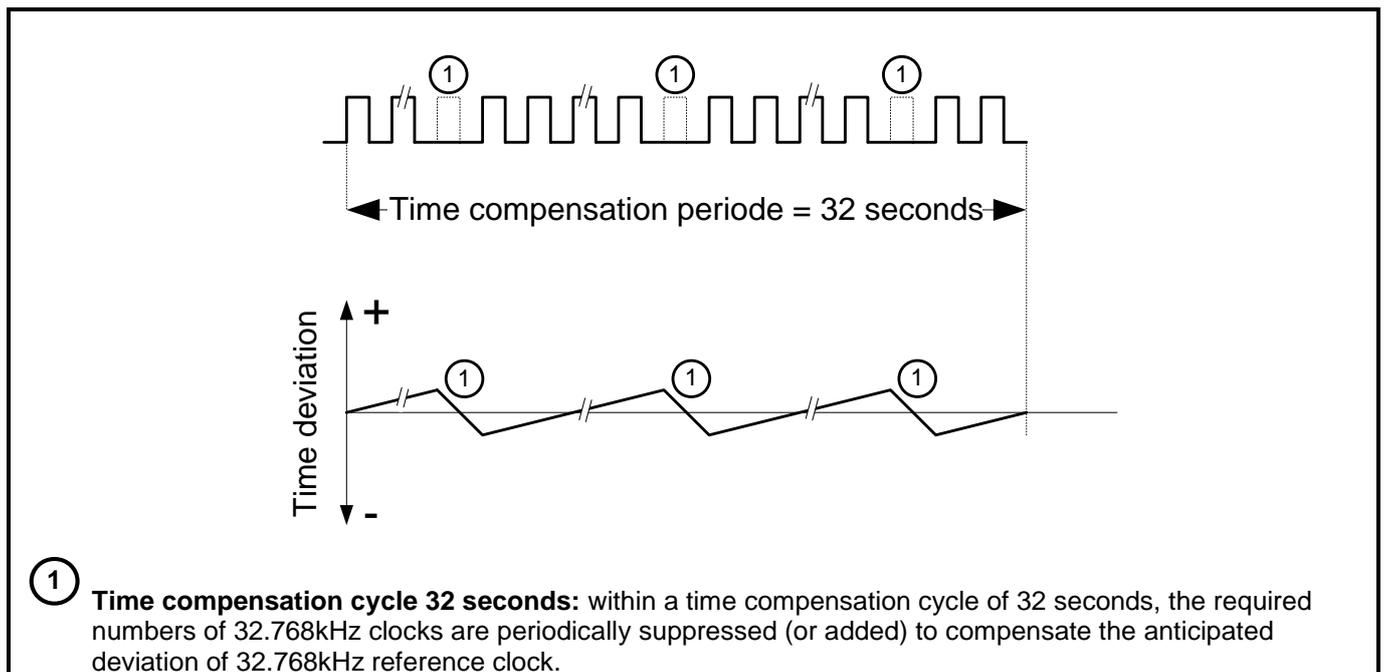

**Effect of correction clocks:**

- CLKOUT 32.768 kHz: not affected, this frequency is not compensated
- CLKOUT 1024 / 32 / 1 Hz: affected, these frequencies are compensated
- Timer / \overline{INT} Output: affected; the internal Timer Source Clocks are compensated
- Time / Date affected; time & date information are compensated

5.3.1.CORRECT METHOD FOR TESTING THE TIME ACCURACY

The compensation method of adding or subtracting correction clocks is changing the period of a single second; therefore the duration of single seconds may vary within a compensation cycle of 32 seconds.

For a test result correctly representing the time accuracy of the RTC module, it is mandatory to measure the device during one complete compensation cycle of 32 seconds.

When the device is tested over a shorter period of time, an error will be caused by the test method and shall be considered for interpretation of the test-results:

<u>Measuring Time</u>	<u>Resolution of Compensation Method</u>	<u>Test Error / Deviation per Day</u>
1 second	± 1 clock (32.768 kHz)	± 30.5 ppm / ± 2.7 sec. per day
2 seconds	± 1 clock (32.768 kHz)	± 15.3 ppm / ± 1.3 sec. per day
4 seconds	± 1 clock (32.768 kHz)	± 7.7 ppm / ± 0.7 sec. per day
8 seconds	± 1 clock (32.768 kHz)	± 3.9 ppm / ± 0.4 sec. per day
32 seconds	± 1 clock (32.768 kHz)	represents real performance

5.3.2.TESTING THE TIME ACCURACY USING CLKOUT OUTPUT

The simplest method to test the time accuracy of the Frequency Compensation Unit (FCU) is by measuring the compensated frequencies at the CLKOUT pin.

Enable temperature compensation:

- Select scanning interval 1 s: set "ThP" = "0" (bit 0 register EEPROM Control)
- Enable thermometer: set "ThE" = "1" (bit 1 register EEPROM Control)

Select compensated frequency at CLKOUT:

- Set CLKOUT frequency: set "FD0" / "FD1" (bits 1&3 register EEPROM Control) to select CLKOUT frequency = 1024Hz or alternatively 1Hz

Measuring equipment and setup:

- Use appropriate frequency counter: for example Agilent A53132A Universal Counter
- Correct setup: set gate time to 32 seconds (one complete compensation cycle) to measure frequency and calculate time deviation upon the measured frequency deviation

5.3.3. TESTING THE TIME ACCURACY USING INTERRUPT OUTPUT 1 Hz

The internal Countdown Timer can be used to generate a 1 Hz test signal at the $\overline{\text{INT}}$ output. However, this procedure is more complicated than using CLKOUT, therefore the following instructions shall be read carefully to avoid mistakes.

Enable temperature compensation:

- Select scanning interval 1 s: set "ThP" = "0" (bit 0 register EEPROM Control)
- Enable thermometer: set "ThE" = "1" (bit 1 register EEPROM Control)

Set appropriate test condition using Countdown Timer & 1 Hz $\overline{\text{INT}}$ Output:

- Disable Timer: set "TE" = "0" (bit 1 register Control_1)
- Disable Timer Auto-Reload Mode: set "TAR" = "0" (bit 2 register Control_1)

Timer & Timer Auto Reload Mode needs to be disabled to allow changes in settings of the Timer Source Clock and Countdown Timer value.

- Set Timer Source Clock = 8 Hz: set "TD0" = "1" & "TD1" = "0" (bit 5&6 register Control_1)
- Set Countdown Timer Value n = 7: set register "Timer Low" = 07h (bit 0-7 register Timer Low)
set register "Timer High" = 00h (bit 0-7 register Timer High)
- Enable Timer Interrupt: set "TIE" = "1" (bit 1 register Control_INT)
- Set Timer in Auto-Reload Mode: set "TAR" = "1" (bit 2 register Control_1)
- Enable Timer: set "TE" = "1" (bit 1 register Control_1)

Prepare MCU Software Driver to clear $\overline{\text{INT}}$ signal:

- MCU clears $\overline{\text{INT}}$ signal: clear $\overline{\text{INT}}$ by setting "TF" = "0" (bit 1 register Control_INT Flag)

Measuring equipment and setup:

- Use appropriate frequency counter: for example Agilent A53132A Universal Counter
- Gate time: set gate time to 32 seconds (one complete compensation cycle)
- Trigger to negative slope: set trigger to falling edge (negative slope)

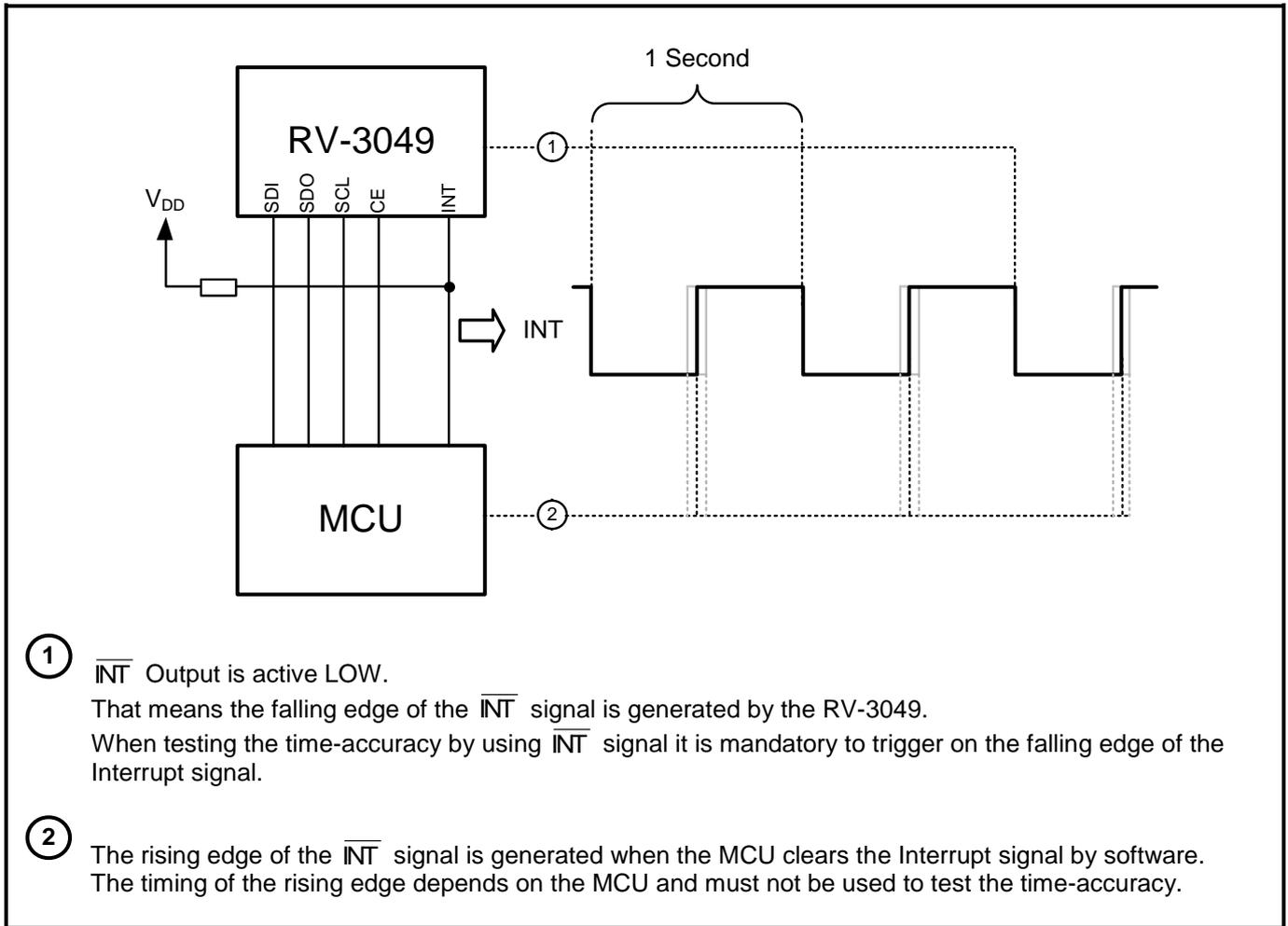

5.4. TIME ACCURACY OPT: A / OPT: B

Option A: parts individually calibrated over the temperature range

To obtain the best possible accuracy over the temperature-range, Option A parts are individually calibrated over the entire temperature range.

XTAL offset:	Frequency deviation @ 25°C	Individually compensated
XTAL T ₀ :	Turnover temperature	Individually calibrated over temperature
XTAL temp. coefficient:	Frequency drift vs temperature	Individually calibrated over temperature
Thermometer error:	Thermometer accuracy	Individually acquired over temperature, correction value individually embedded in XTAL parameters

Every part RV-3049 Opt: A is individually measured over the temperature range to derive thermometer's and crystal's characteristics over the temperature range in order to achieve optimized time accuracy. Based on the temperature data, frequency correction values are calculated and individually programmed into the corresponding EEPROM register by the factory.

Below chart shows the time deviation of 30 tested devices over the temperature range of 30 individually calibrated RTC's (Opt: A) after the components were reflow soldered onto a PCB, the red dotted line shows the specified time accuracy for Option: A devices.

Option A:	Temperature range	Time deviation
	25°C	±3 ppm = ±0.26 seconds per day
	0°C to + 50°C	±4 ppm = ±0.35 seconds per day
	-10°C to + 60°C	±5 ppm = ±0.44 seconds per day
	-40°C to + 85°C	±6 ppm = ±0.52 seconds per day
	-40°C to +125°C	±8 ppm = ±0.70 seconds per day

**Option: A (calibrated)
Time Deviation vs. Temperature**

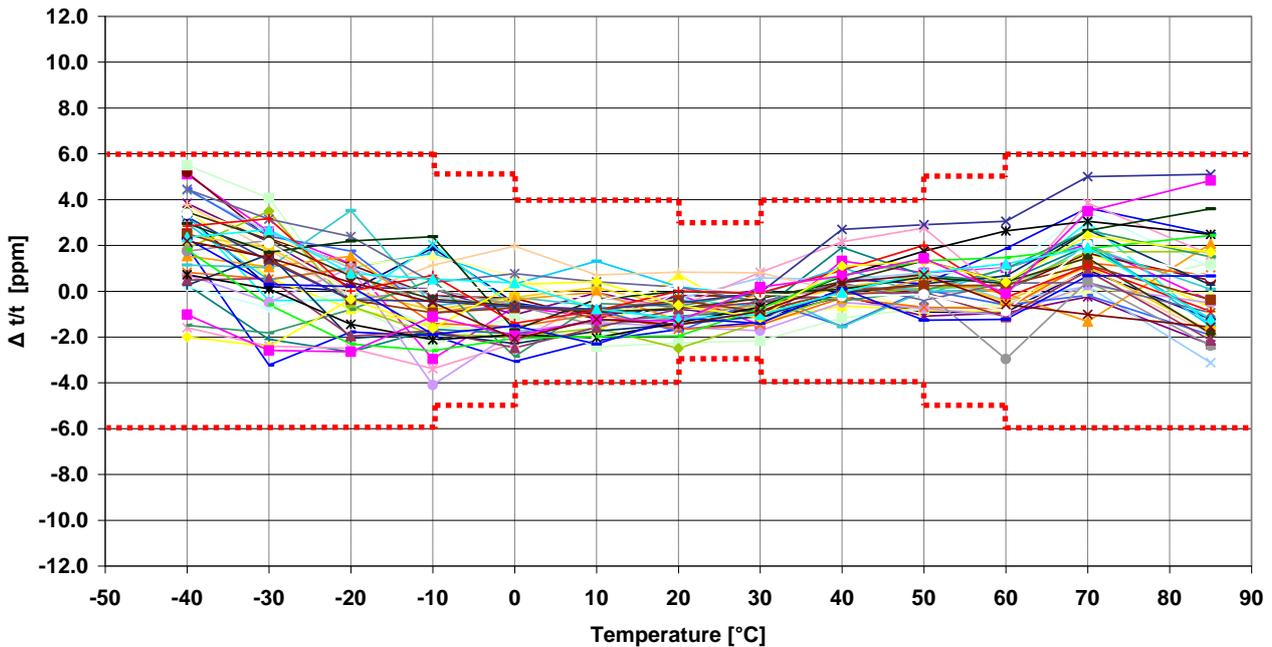

Option B: parts individually calibrated based on generic temperature data

The Option: B devices are designed for an optimized trade off accuracy vs cost. Option B parts are individually programmed to compensate the frequency deviation at 25°C but using generic batch data to compensate the crystal's temperature characteristics. Option B parts offer a good time accuracy at little cost.

XTAL offset:	Frequency deviation @ 25°C	Individually compensated
XTAL T ₀ :	Turnover Temperature	Compensated with generic batch data
XTAL temp. coefficient:	Frequency drift vs temperature	Compensated with generic batch data
Thermometer error:	Thermometer accuracy	Individually acquired at 25°C, correction value individually embedded in XTAL parameters

Samples of RV-3049 Opt: B parts are individually measured over the temperature range to derive the generic batch data for the thermometer's and crystal's characteristics over the temperature range. Based on the temperature data, frequency correction values are calculated and individually programmed into the corresponding EEPROM register by the factory.

Below chart shows the time deviation of 30 tested devices over the temperature-range of individually calibrated RTC's (Opt: B) after the components were reflow soldered onto a PCB, the red dotted line shows the specified time accuracy for Option: B devices.

Option B:	Temperature range	Time deviation
	25°C	± 3 ppm = ±0.26 seconds per day
	0°C to + 50°C	± 5 ppm = ±0.44 seconds per day
	-10°C to + 60°C	±10 ppm = ±0.87 seconds per day
	-40°C to + 85°C	±25 ppm = ±2.17 seconds per day
	-40°C to +125°C	±30 ppm = ±2.60 seconds per day

**Option: B (default)
Time Deviation vs. Temperature**

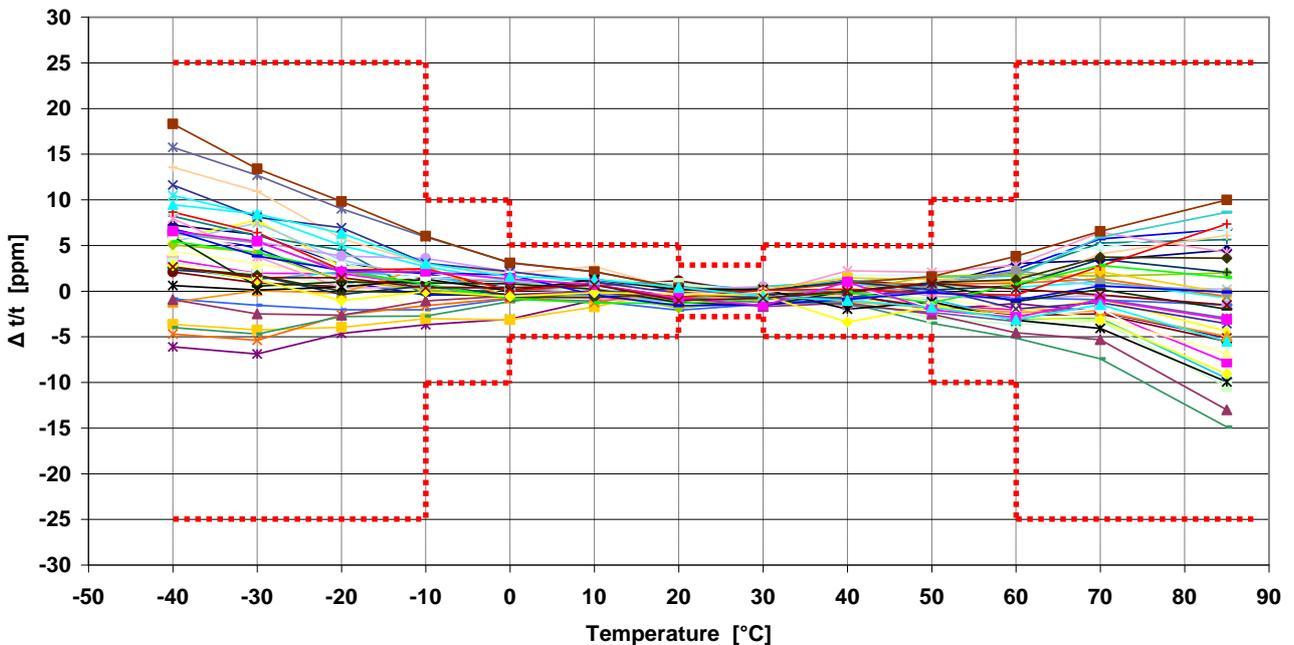

6. SPI INTERFACE

SPI Interface connects Master and one or multiple Slave devices. Data transfer to and from the devices is made via a 4-wire (3-wire) SPI bus. The four lines are: **Chip Enable (CE)**, **Serial-Clock (SCL)**, **Serial-Data-Output (SDO)** and **Serial-Data-Input (SDI)**.

The chip enable signal CE is used to enable the considered device and to identify the transmitted data.

The data lines for input and output are split into two separate lines. However, the Data-Input SDI and Data-Output SDO lines can be connected together to facilitate a bidirectional data bus in single wire mode.

6.1. SPI INTERFACE SYSTEM CONFIGURATION

SPI Serial Interface

Symbol	Function	Description
SCL	Serial Clock Input	Serial Clock Input pin; this Input may float when CE is LOW (inactive), may be higher than V_{DD}
SDI	Serial Data Input	Serial Data Input pin; this Input may float when CE is LOW (inactive), may be higher than V_{DD} ; input data is sampled on the rising edge of SCL
SDO	Serial Data Output	Serial Data Output pin; push-pull drives from V_{SS} to V_{DD} ; high-impedance when not driving; can be connected to SDI for single-wire data line, output data is changed on the falling edge of SCL
CE	Chip Enable input	Chip Enable input active HIGH but may not be wired permanently HIGH, with internal 100 k Ω pull-down resistor, when LOW the interface is reset.

SDI / SDO Configurations

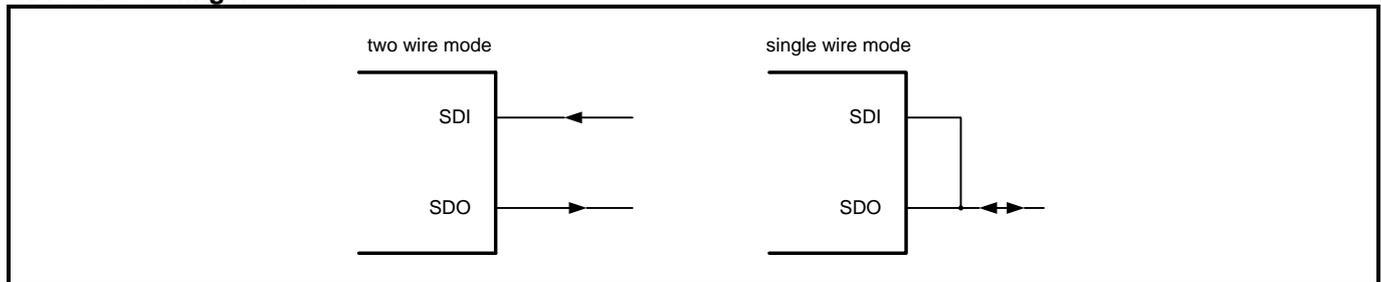

Note:

The data lines for input and output are split into two separate lines, however, the Data-Input SDI and Data-Output SDO lines can be connected together to facilitate a bidirectional data bus in single wire mode.

Application Diagram

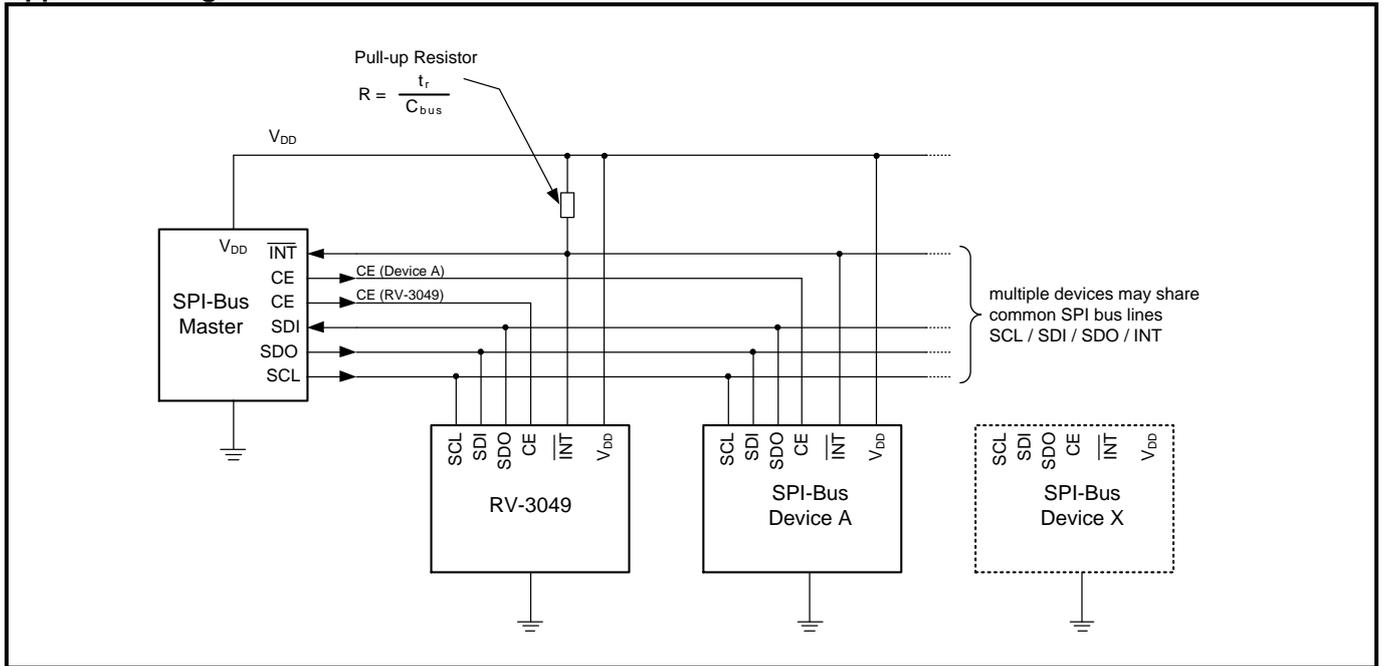

6.2. SPI INTERFACE DATA TRANSMISSION

The data transmission is controlled by the active HIGH chip enable signal CE. The data transfer is initiated by the Master by raising the chip enable signal CE of the considered Slave device to “1”.

At the beginning of SPI bus data transmission, a copy of the content of the addressed Watch, Alarm, Timer and Temperature registers is stored into a cache memory. During read / write operation, data are provided from this cache memory.

To prevent faulty reading, data in the cache memory are kept stable until the SPI bus data transmission is terminated. When the Master is pulling the CE to “0”, the content of the modified registers in the cache memory are copied back into the corresponding Watch, Alarm, Timer and Temperature registers.

Each data transfer is a byte, with the Most Significant Bit (MSB) sent first. The first byte transmitted is the Command Byte, defining the address of the first register to be accessed and the read or write mode.

One data bit is transferred during each SCL clock pulse. Data are sampled on the rising edge of the SCL clock and internally transferred on the falling edge of the SCL clock. In idle mode, SCL shall be LOW.

The register address (within the same page) will automatically increment after transmission of every byte. The page address remains unchanged until data transfer is stopped and a new data transfer is initiated. Therefore, CE must return LOW before a new data transfer can be executed.

Data transfer is terminated by the Master by pulling the chip enable CE of the addressed Slave device to “0”.

Data Transfer Overview

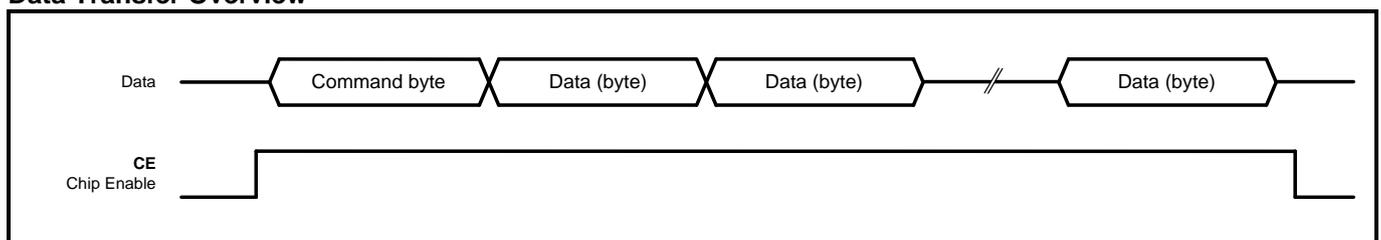

6.2.1.COMMAND BYTE DEFINITION

Bit	Symbol	Value	Description
7	R/W	Data read or write selection	
		0	Write data; master writes data on the SDI line
		1	Read data; RV-3049 writes data on the SDO line
6 to 3	PA	-0xxx	Page Address; the not transmitted bit 7 of the page address is set internally to = “0”
2 to 0	RA	000 111	Register Address; will be automatically incremented after transmission of each byte

6.2.2.SPI INTERFACE READ / WRITE EXAMPLES

Serial bus read example (reading the Seconds register address 08h and Minutes register address 09h)

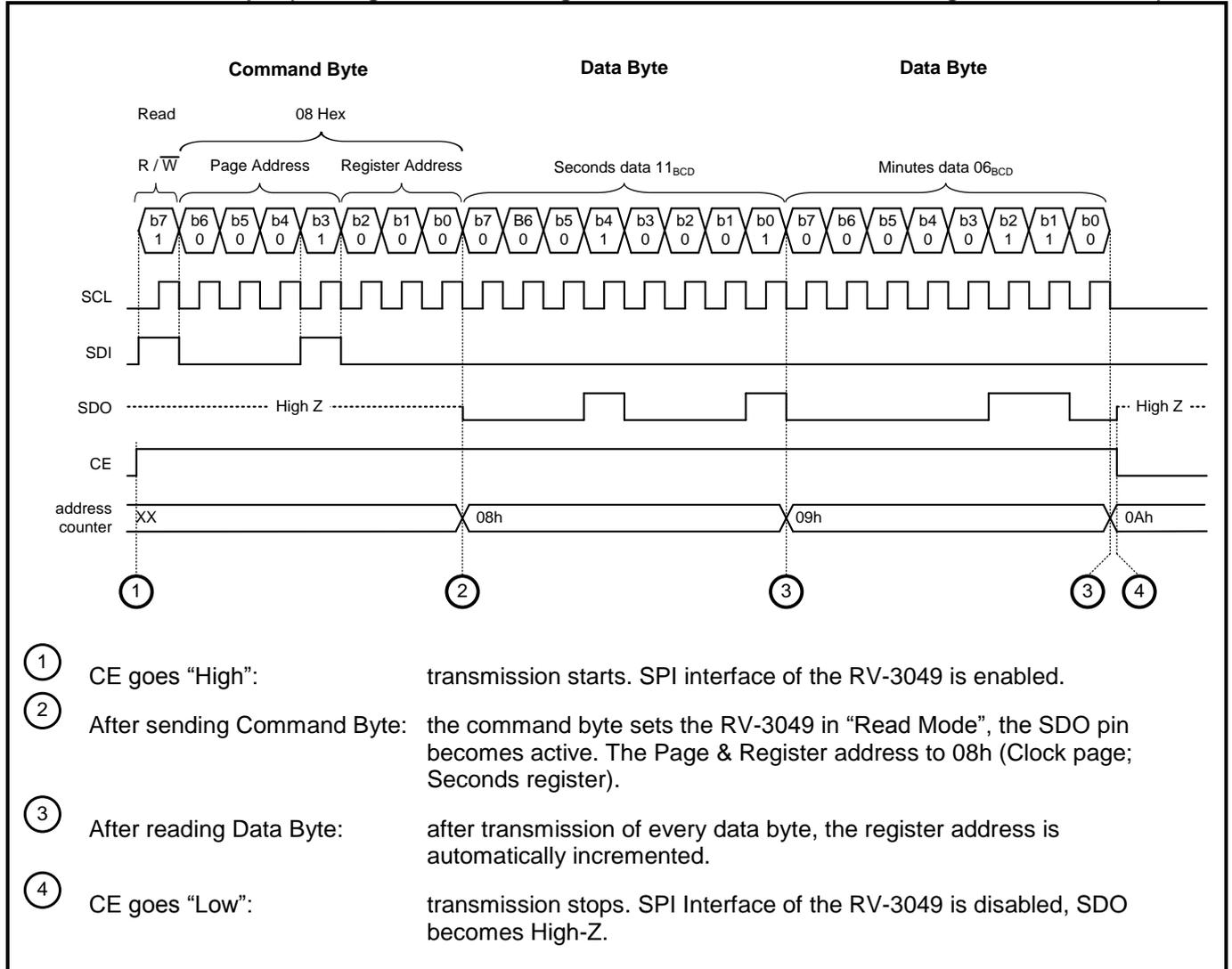

Note:

In this example, the Seconds and Minutes registers are read. Pins SDI and SDO are not connected together; in this configuration it is important that SDI pin is never left floating. It always must be driven either HIGH or LOW. If pin SDI is left open, high I_{DD} currents may result; short transition periods in the order of 200 ns will not cause any problems.

Serial bus write example (Seconds register set to 45 seconds, Minutes register set to 10 minutes)

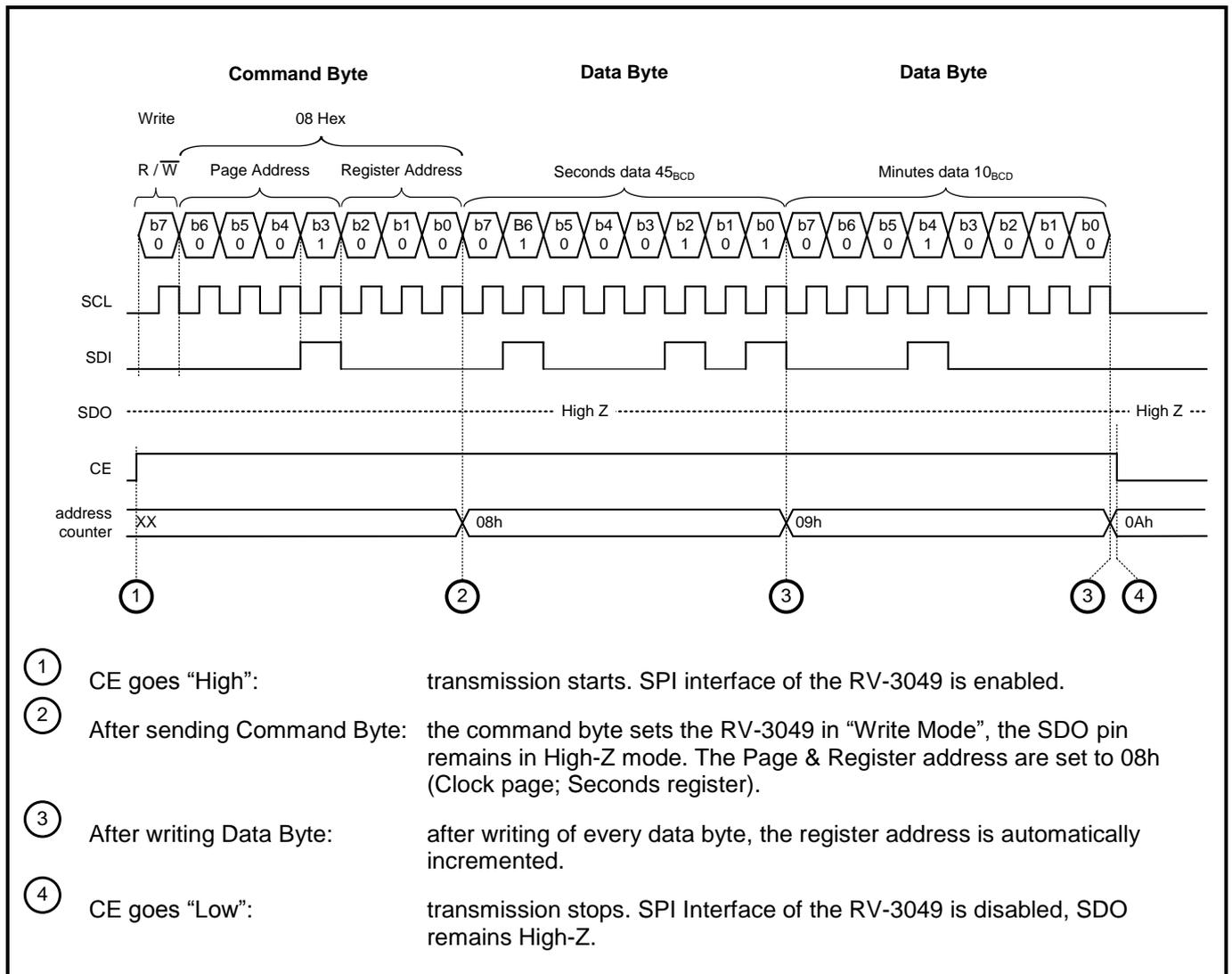

Note:

In this example, the Seconds and Minutes registers are written. Pins SDI and SDO are not connected together, since the device is accessed in write mode the SDO line remains High-Z during the whole transmission.

7. ELECTRICAL CHARACTERISTICS

7.1. ABSOLUTE MAXIMUM RATINGS

In accordance with the Absolute Maximum Rating System IEC 60134

PARAMETER	SYMBOL	CONDITIONS	MIN.	MAX.	UNIT
Supply voltage	V_{DD}	$>GND / <V_{DD}$	GND -0.3	+6.0	V
Supply current	$I_{DD} ; I_{SS}$	V_{DD} Pin	-50	+50	mA
Input voltage	V_I	Input Pin	GND -0.3	$V_{DD} + 0.3$	V
Output voltage	V_O	$\overline{INT} / CLKOUT$	GND -0.5	$V_{DD} + 0.5$	V
DC Input current	I_I		-10	+10	mA
DC Output current	I_O		-10	+10	mA
Total power dissipation	P_{TOT}			300	mW
Operating ambient temperature range	T_{OPR}		-40	+125	°C
Storage temperature range	T_{STO}	Stored as bare product	-55	+125	°C
Electro Static Discharge voltage	V_{ESD}	HBM ¹⁾ MM ²⁾		± 2000 ± 300	V
Latch-up current	I_{LU} ³⁾			200	mA

¹⁾HBM: Human Body Model, according to JESD22-A114.

²⁾MM: Machine Model, according to JESD22-A115.

³⁾Latch-up testing, according to JESD78.

Stresses above these listed maximum ratings may cause permanent damage to the device. Exposure beyond specified operating conditions may affect device reliability or cause malfunction.

7.2. FREQUENCY AND TIME CHARACTERISTICS

$V_{DD} = 3.0$ V; $V_{SS} = 0$ V; $T_{amb} = +25$ °C; $f_{OSC} = 32.768$ kHz

PARAMETER	SYMBOL	CONDITIONS	TYP.	MAX.	UNIT
32.768 kHz Oscillator Characteristics					
Frequency accuracy	$\Delta f/f$	$F_{CLKOUT} = 32.768$ kHz $T_{amb} = +25$ °C $V_{DD} = 3.0$ V	+/-10	+/-20	ppm
Frequency vs. voltage characteristics	$\Delta f/(f\Delta V)$	$T_{amb} = +25$ °C $V_{DD} = 1.4$ V to 5.5 V	+/-0.5	+/-1.0	ppm/V
Frequency vs. temperature characteristics	$\Delta f/T_{OPR}$	$T_{OPR} = -40$ °C to +125°C $V_{DD} = 3.0$ V	$-0.035^{ppm}/^{\circ}C \cdot (T_{OPR} - T_0)^2$ (+/-10%)		ppm
Turnover temperature	T_O		+25	20 - 30	°C
Aging first year max.	$\Delta f/f$	$T_{amb} = +25$ °C		+/-3	ppm
Oscillator start-up voltage	V_{Start}	$T_{amb} = +25$ °C $T_{Start} < 10$ s	1.0		V
Oscillator start-up time	T_{Start}	$T_{amb} = -40$ °C to +85°C	0.5	3	s
		$T_{amb} = -40$ °C to +125°C	1	3	
CLKOUT duty cycle		$F_{CLKOUT} = 32.768$ kHz $T_{AMB} = +25$ °C	50	40/60	%
Time accuracy, DTCXO Digitally Temperature Compensated					
Time accuracy Opt: A	$\Delta t/t$	$T_{amb} = +25$ °C	+/-1	+/-3	ppm
		$T_{amb} = 0$ °C to +50°C	+/-2	+/-4	
		$T_{amb} = -10$ °C to +65°C	+/-3	+/-5	
		$T_{amb} = -40$ °C to +85°C	+/-4	+/-6	
		$T_{amb} = -40$ °C to +125°C	+/-5	+/-8	
Time accuracy Opt: B	$\Delta t/t$	$T_{amb} = +25$ °C	+/-1	+/-3	ppm
		$T_{amb} = 0$ °C to +50°C	+/-3	+/-5	
		$T_{amb} = -10$ °C to +65°C	+/-5	+/-10	
		$T_{amb} = -40$ °C to +85°C	+/-10	+/-25	
		$T_{amb} = -40$ °C to +125°C	+/-15	+/-30	



7.3. STATIC CHARACTERISTICS

$V_{DD} = 1.4 \text{ V to } 5.5 \text{ V}$; $V_{SS} = 0 \text{ V}$; $T_{amb} = -40^{\circ}\text{C to } +125^{\circ}\text{C}$; $f_{OSC} = 32.768 \text{ kHz}$

PARAMETER	SYMBOL	CONDITIONS	MIN.	TYP.	MAX.	UNIT
Supplies						
Supply voltage	V_{DD}	Time-keeping mode SPI bus reduced speed	1.4		5.5	V
		SPI bus full speed	3.0		5.5	V
Minimum supply voltage detection	V_{LOW1}	$T_{amb} = -40^{\circ}\text{C to } +125^{\circ}\text{C}$	1.8		2.1	V
Minimum supply voltage detection	V_{LOW2}	$T_{amb} = -40^{\circ}\text{C to } +125^{\circ}\text{C}$	1.0		1.4	V
Main Supply to Backup Supply Switchover Hysteresis	V_{HYST}	V_{DD} to $V_{BACK} = 3.0 \text{ V}$		20		mV
Supply current SPI bus inactive CLKOUT disabled $V_{BACK} = 0 \text{ V}$ or $V_{DD} = 0 \text{ V}$	I_{DD} ($V_{BACK} = 0 \text{ V}$)	$V_{DD} = 1.4 \text{ V}$ $T_{amb} = -40^{\circ}\text{C to } +85^{\circ}\text{C}$		0.6	1.5	μA
		$V_{DD} = 1.4 \text{ V}$ $T_{amb} = -40^{\circ}\text{C to } +125^{\circ}\text{C}$			4.6	μA
	or I_{BACK} ($V_{DD} = 0 \text{ V}$)	$V_{DD} = 3.3 \text{ V}$ $T_{amb} = -40^{\circ}\text{C to } +85^{\circ}\text{C}$		0.8	2.0	μA
		$V_{DD} = 3.3 \text{ V}$ $T_{amb} = -40^{\circ}\text{C to } +125^{\circ}\text{C}$			5.2	μA
		$V_{DD} = 5.0 \text{ V}$ $T_{amb} = -40^{\circ}\text{C to } +85^{\circ}\text{C}$		0.9	2.2	μA
		$V_{DD} = 5.0 \text{ V}$ $T_{amb} = -40^{\circ}\text{C to } +125^{\circ}\text{C}$			5.5	μA
Supply current SPI bus active CLKOUT disabled	I_{DD}	SCL = 200 kHz $V_{DD} = 1.4 \text{ V}$ $T_{amb} = -40^{\circ}\text{C to } +85^{\circ}\text{C}$			14	μA
		SCL = 200 kHz $V_{DD} = 1.4 \text{ V}$ $T_{amb} = -40^{\circ}\text{C to } +125^{\circ}\text{C}$			18	μA
		SCL = 1 MHz $V_{DD} = 3.3 \text{ V}$ $T_{amb} = -40^{\circ}\text{C to } +85^{\circ}\text{C}$			50	μA
		SCL = 1 MHz $V_{DD} = 3.3 \text{ V}$ $T_{amb} = -40^{\circ}\text{C to } +125^{\circ}\text{C}$			55	μA
		SCL = 1 MHz $V_{DD} = 5.0 \text{ V}$ $T_{amb} = -40^{\circ}\text{C to } +85^{\circ}\text{C}$			65	μA
		SCL = 1 MHz $V_{DD} = 5.0 \text{ V}$ $T_{amb} = -40^{\circ}\text{C to } +125^{\circ}\text{C}$			75	μA
Current consumption SPI bus inactive CLKOUT = 32.768kHz, $C_{LOAD} = 7.5\text{pF}$	I_{DD32K}	$V_{DD} = 5.0\text{V}$		2.5	3.4	μA
		$V_{DD} = 3.3\text{V}$		1.5	2.2	μA
		$V_{DD} = 1.4\text{V}$		1.1	1.6	μA
Inputs						
LOW level input voltage	V_{IL}	$V_{DD} = 1.4 \text{ V to } 5.0\text{V}$ Pins: SCL, SDI, CLKOE, CE			20% V_{DD}	V
HIGH level input voltage	V_{IH}		80% V_{DD}			V
Input leakage current $V_{SS} > V_I < V_{DD}$	I_L	$T_{amb} = -40^{\circ}\text{C to } +85^{\circ}\text{C}$	-1		+1	μA
		$T_{amb} = -40^{\circ}\text{C to } +125^{\circ}\text{C}$	-1.5		+1.5	μA
Input capacitance	C_I				7	pF
Outputs						
HIGH level output voltage	V_{OH}	$V_{DD} = 1.4\text{V}; I_{OH} = 0.1\text{mA}$	1.0			V
		$V_{DD} = 3.3\text{V}; I_{OH} = 1.5\text{mA}$	2.7			
		$V_{DD} = 5.0\text{V}; I_{OH} = 2.0\text{mA}$	4.5			
LOW level output voltage	V_{OL}	$V_{DD} = 1.4\text{V}; I_{OL} = 0.4\text{mA}$			0.2	V
		$V_{DD} = 3.3\text{V}; I_{OL} = 1.5\text{mA}$			0.25	
		$V_{DD} = 5.0\text{V}; I_{OL} = 5.0\text{mA}$			0.8	
HIGH level output current	I_{OH}	$V_{OH} = 4.5 \text{ V} / V_{DD} = 5 \text{ V}$			2.0	mA
LOW level output current	I_{OL}	$V_{OL} = 0.8 \text{ V} / V_{DD} = 5 \text{ V}$			-5.0	mA
Output leakage current	I_{LO}	$V_O = V_{DD}$ or V_{SS} $T_{amb} = -40^{\circ}\text{C to } +85^{\circ}\text{C}$	-1	0	+1	μA
		$V_O = V_{DD}$ or V_{SS} $T_{amb} = -40^{\circ}\text{C to } +125^{\circ}\text{C}$	-1.5	0	+1.5	
Operating Temperature Range						
Operating temperature range	T_{OPR}		-40		+125	$^{\circ}\text{C}$

PARAMETER	SYMBOL	CONDITIONS	MIN.	TYP.	MAX.	UNIT
EEPROM Characteristics						
Read voltage	V_{Read}	$T_{amb} = -40^{\circ}C$ to $+125^{\circ}C$	1.4			V
Programming voltage	V_{Prog}	$T_{amb} = -40^{\circ}C$ to $+125^{\circ}C$	2.2			V
EEPROM Programming Time	T_{Prog}	$T_{amb} = -40^{\circ}C$ to $+125^{\circ}C$ 1 Byte EEPROM User			35	ms
EEPROM Programming Time	T_{Prog}	$T_{amb} = -40^{\circ}C$ to $+125^{\circ}C$ 1 Byte EEPROM Control			100	ms
EEPROM Programming Time	T_{Prog}	$T_{amb} = -40^{\circ}C$ to $+125^{\circ}C$ 2-4 Byte EEPROM Control			135	ms
EEPROM write / erase cycles	V_{HYST}	V_{DD} to $V_{BACK} = 3.0$ V	5000			Cycles
Trickle charger						
Current limiting resistors $V_{DD} = 5.0V$ $V_{BACK} = 3.0V$	R80k	$T_{amb} = 25^{\circ}C$		80		k Ω
	R20k	$T_{amb} = 25^{\circ}C$		20		
	R5k	$T_{amb} = 25^{\circ}C$		5		
	R1.5k	$T_{amb} = 25^{\circ}C$		1.5		
Thermometer						
Thermometer precision	T_E	$T_{amb} = -40^{\circ}C$ to $+85^{\circ}C$		+/-4		$^{\circ}C$
		$T_{amb} = -40^{\circ}C$ to $+125^{\circ}C$		+/-6		

7.4. SPI INTERFACE TIMING CHARACTERISTICS

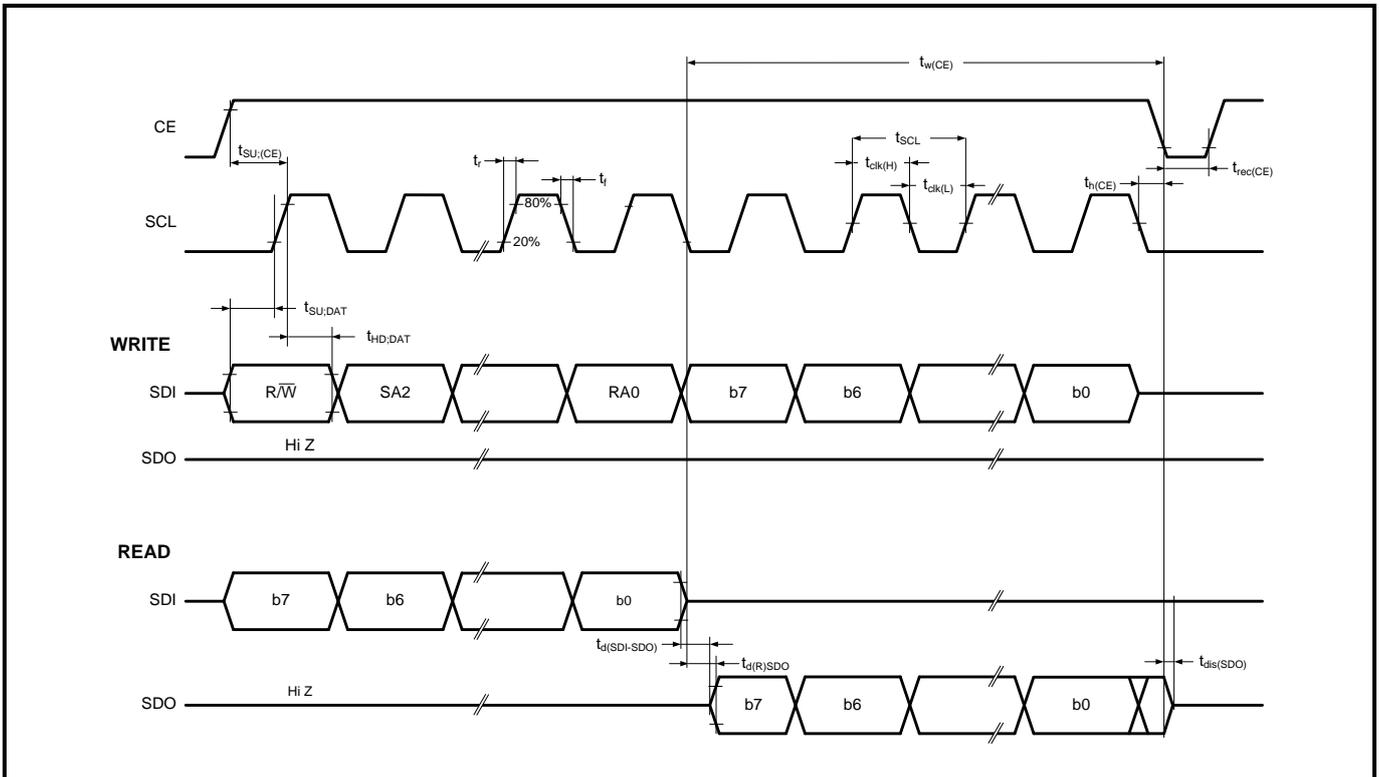



7.5. SPI INTERFACE DYNAMIC CHARACTERISTICS

$V_{SS} = 0\text{ V}$; $T_{amb} = -40^{\circ}\text{C}$ to $+125^{\circ}\text{C}$. All timing values are valid within the operating supply voltage range and references to V_{IL} and V_{IH} with an input voltage swing from V_{SS} to V_{DD} .

PARAMETER	SYMBOL	CONDITIONS	$V_{DD} = 1.4\text{V}$		$V_{DD} = 1.8\text{V}$		$V_{DD} = 3.0\text{V}$		$V_{DD} = 5.0\text{V}$		UNIT
			MIN	MAX	MIN	MAX	MIN	MAX	MIN	MAX	
SCL clock frequency	$f_{clk(SCL)}$			0.2		0.6		1.0		1.0	MHz
SCL time	t_{SCL}		5		1.7		1		1		μs
Clock HIGH time	$t_{clk(H)}$		1500		700		400		400		ns
Clock LOW time	$t_{clk(L)}$		1500		700		400		400		ns
Rise time	t_r	for SCL signal		800		800		200		200	ns
Fall time	t_r	for SCL signal		800		800		200		200	ns
CE setup time	$t_{su(CE)}$		100		100		100		100		ns
CE hold time	$t_{h(CE)}$		500		300		200		200		ns
CE recovery time	$t_{rec(CE)}$		400		300		200		200		ns
CE pulse width	$t_w(CE)$	Measured after valid sub address is received		0.49		0.49		0.49		0.49	s
Setup time	t_{su}	Setup time for SDI data	20		20		20		20		ns
Hold time	t_h	Hold time for SDI data	500		300		200		200		ns
SDO read delay time	$t_{d(R)SDO}$	Bus load = 50pF		1300		650		350		350	ns
SDO disable time	$t_{dis(SDO)}$	No load value; bus will be held up by bus capacitance; use RC time constant with application values		200		100		50		50	ns
Transition time SDI to SDO	$t_t(SDI-SDO)$	Prepare for 0ns to avoid bus conflict	0		0		0		0		ns

8. APPLICATION INFORMATION

Operating RV-3049 without V_{BACKUP} Supply:

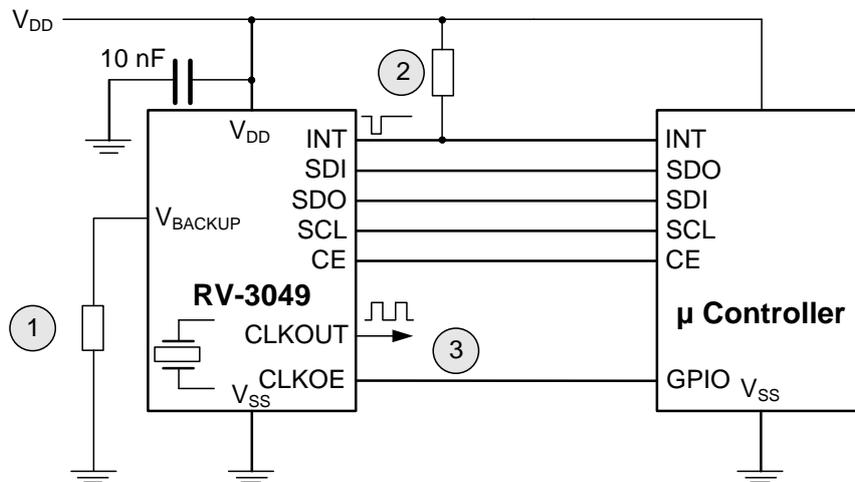

- ① When operating the RV-3049 without Backup Supply Voltage, it is recommended to tie V_{BACKUP} pin to GND, 10 kOhm resistor is recommended.
- ② Pull-up resistor of the \overline{INT} signal can be tied directly to supply voltage V_{DD} .
- ③ CLKOUT is enabled when CLKOE input is high. It either can be permanently enabled with a pull-up resistor to supply voltage V_{DD} or actively controlled by the μ Controller. If no clock function is needed, it is recommended to disable CLKOUT by permanently tie CLKOE pin with a pull-down resistor to GND.

Operating RV-3049 with Backup Supply Voltage V_{BACKUP} :

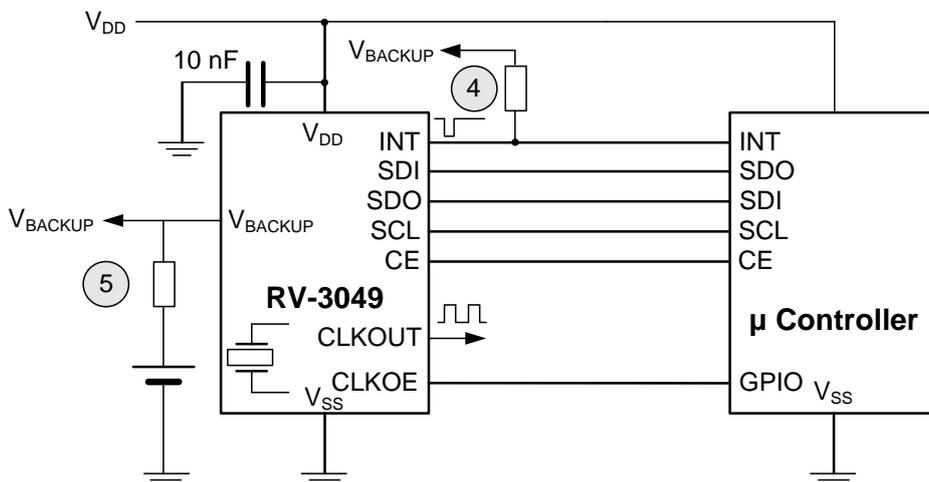

- ④ When operating the RV-3049 with either Supercap or Lithium Battery as Backup Supply, the \overline{INT} signal also works when the device operates on V_{BACKUP} supply voltage. Therefore it is recommended to tie the \overline{INT} pull-up resistor to V_{BACKUP} .
- ⑤ When a Lithium Battery is used, it is recommended to insert a protection resistor of 100 - 1'000 Ohm to limit battery current and to prevent damage in case of soldering issues causing short between supply pins.

8.1. RECOMMENDED REFLOW TEMPERATURE (LEADFREE SOLDERING)

Maximum Reflow Conditions in accordance with IPC/JEDEC J-STD-020C “Pb-free”

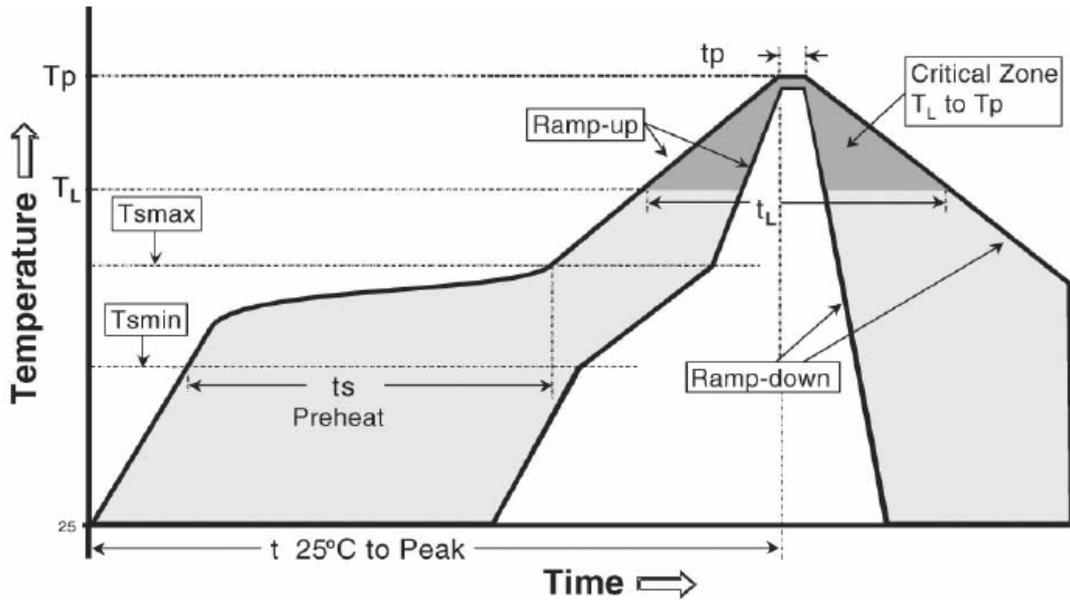

Temperature Profile	Symbol	Condition	Unit
Average ramp-up rate	($T_{s_{max}}$ to T_p)	3°C / second max	°C / s
Ramp down Rate	T_{cool}	6°C / second max	°C / s
Time 25°C to Peak Temperature	$T_{to-peak}$	8 minutes max	m
Preheat			
Temperature min	$T_{s_{min}}$	150	°C
Temperature max	$T_{s_{max}}$	200	°C
Time $T_{s_{min}}$ to $T_{s_{max}}$	t_s	60 - 180	Sec
Soldering above liquidus			
Temperature liquidus	T_L	217	°C
Time above liquidus	t_L	60 - 150	sec
Peak temperature			
Peak Temperature	T_p	260	°C
Time within 5°C of peak temperature	t_p	20 - 40	sec

9. PACKAGE

9.1. DIMENSIONS AND SOLDERPADS LAYOUT

C3 Package:

Package dimensions (bottom view):

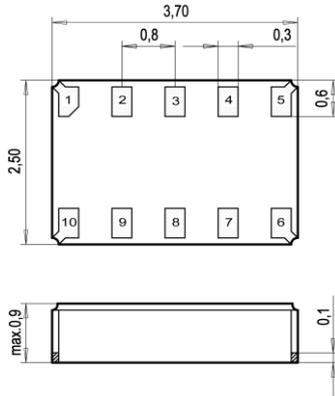

Recommended solderpad layout:

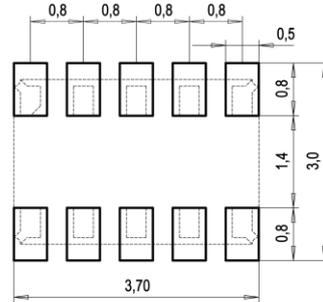

All dimensions in mm typical.

9.2. MARKING AND PIN #1 INDEX

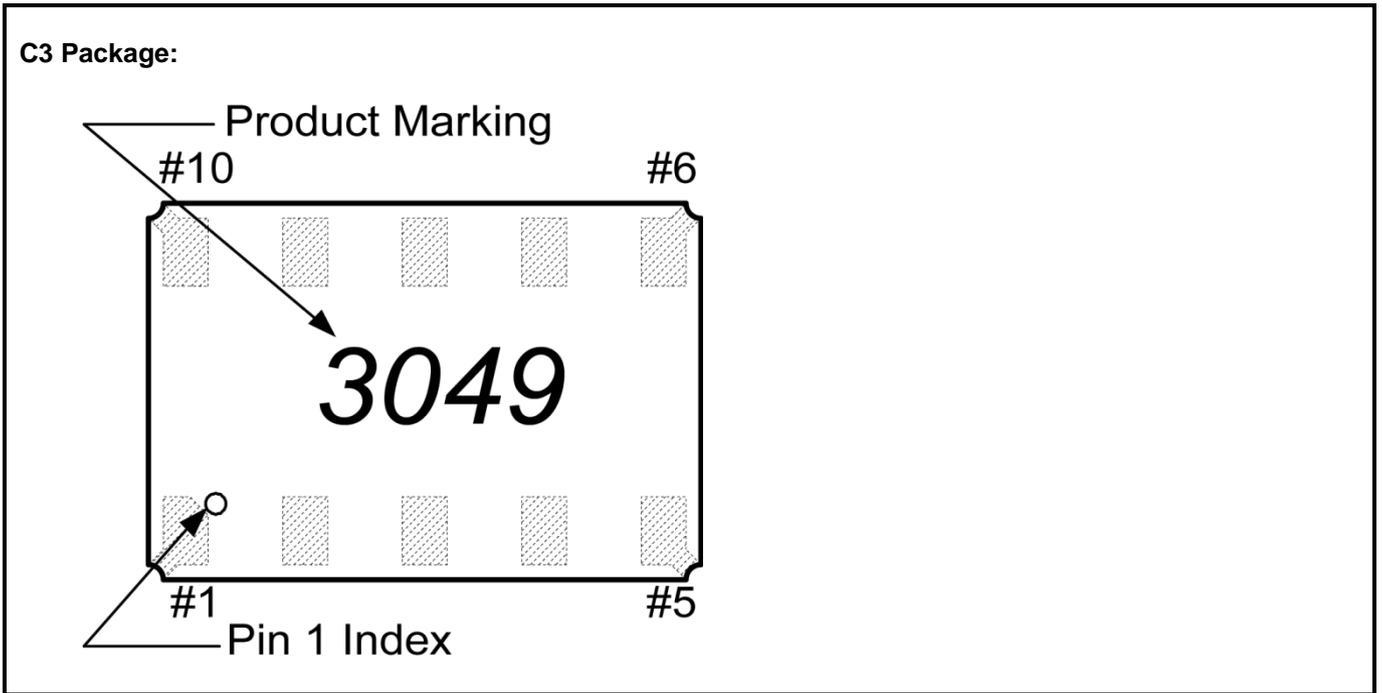

10.PACKING INFORMATION

10.1.CARRIER TAPE

12 mm Carrier-Tape: Material: Polystyrene / Butadine or Polystyrol black, conductive

Cover Tape: Base Material: Polyester, conductive 0.061 mm
 Adhesive Material: Pressure-sensitive Synthetic Polymer

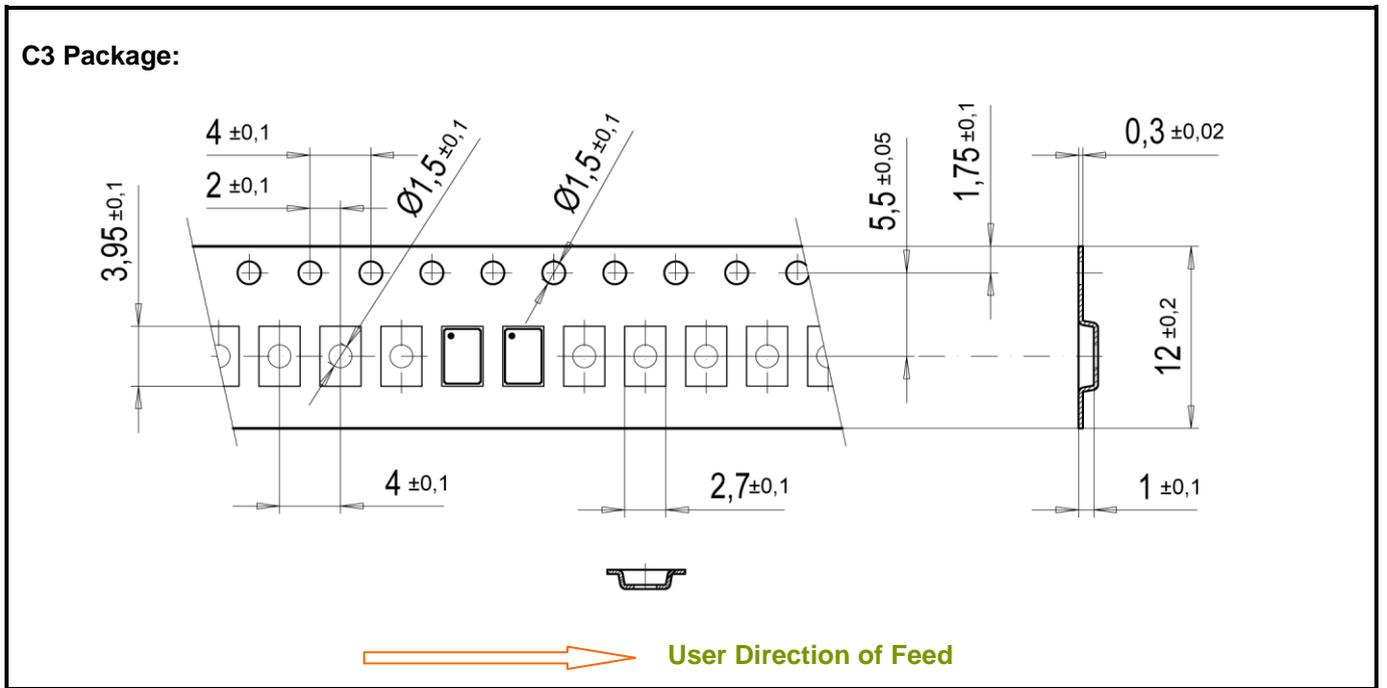

Tape Leader and Trailer: 300 mm minimum.
 All dimensions in mm.



10.2. PARTS PER REEL

C3 Package:

Reels:

Diameter	Material	RTC's per reel
7"	Plastic, Polystyrol	1'000
7"	Plastic, Polystyrol	3'000

10.3. REEL 13 INCH FOR 12 mm TAPE

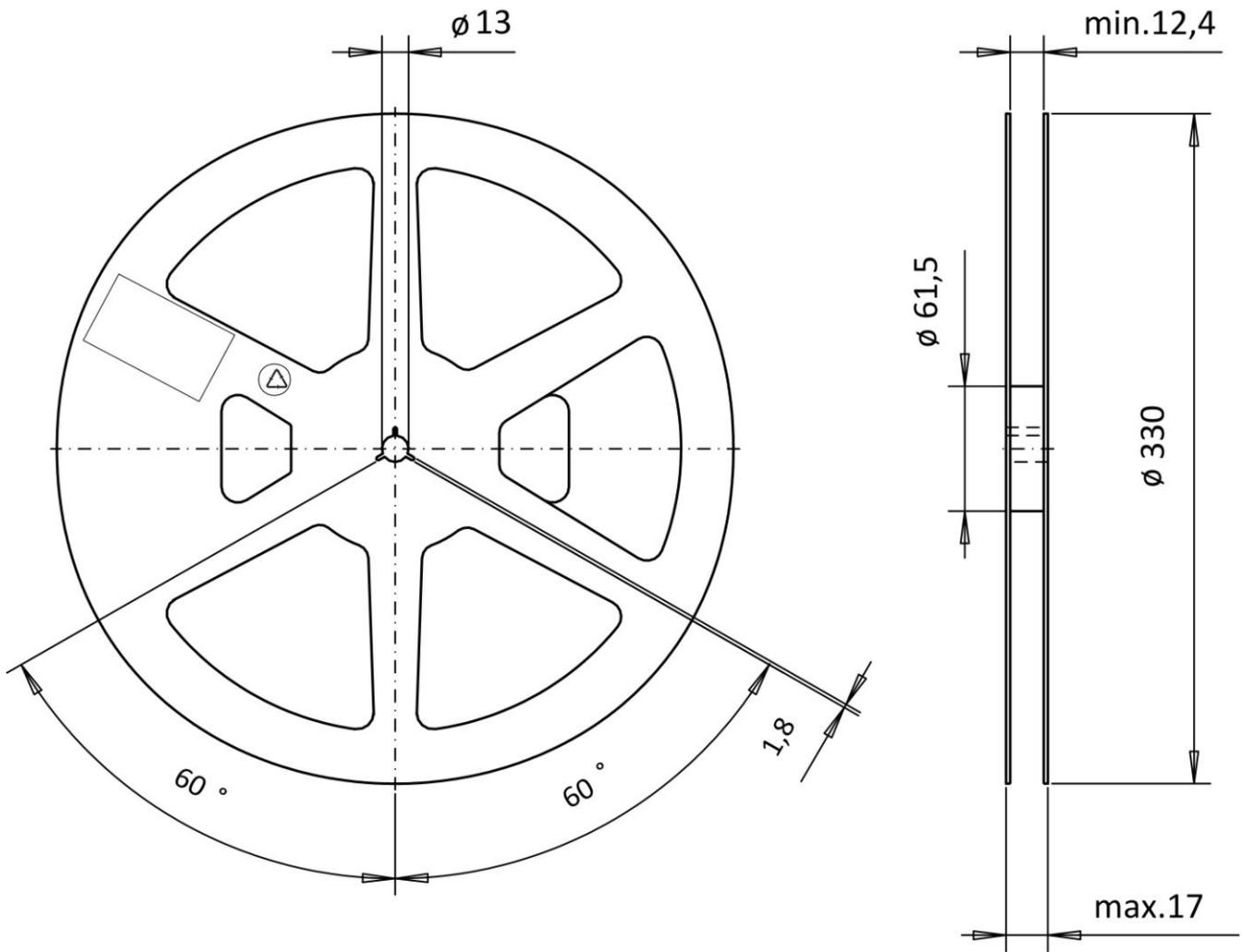

Reel:

Diameter	Material
13"	Plastic, Polystyrol

10.4. REEL 7 INCH FOR 12 mm TAPE

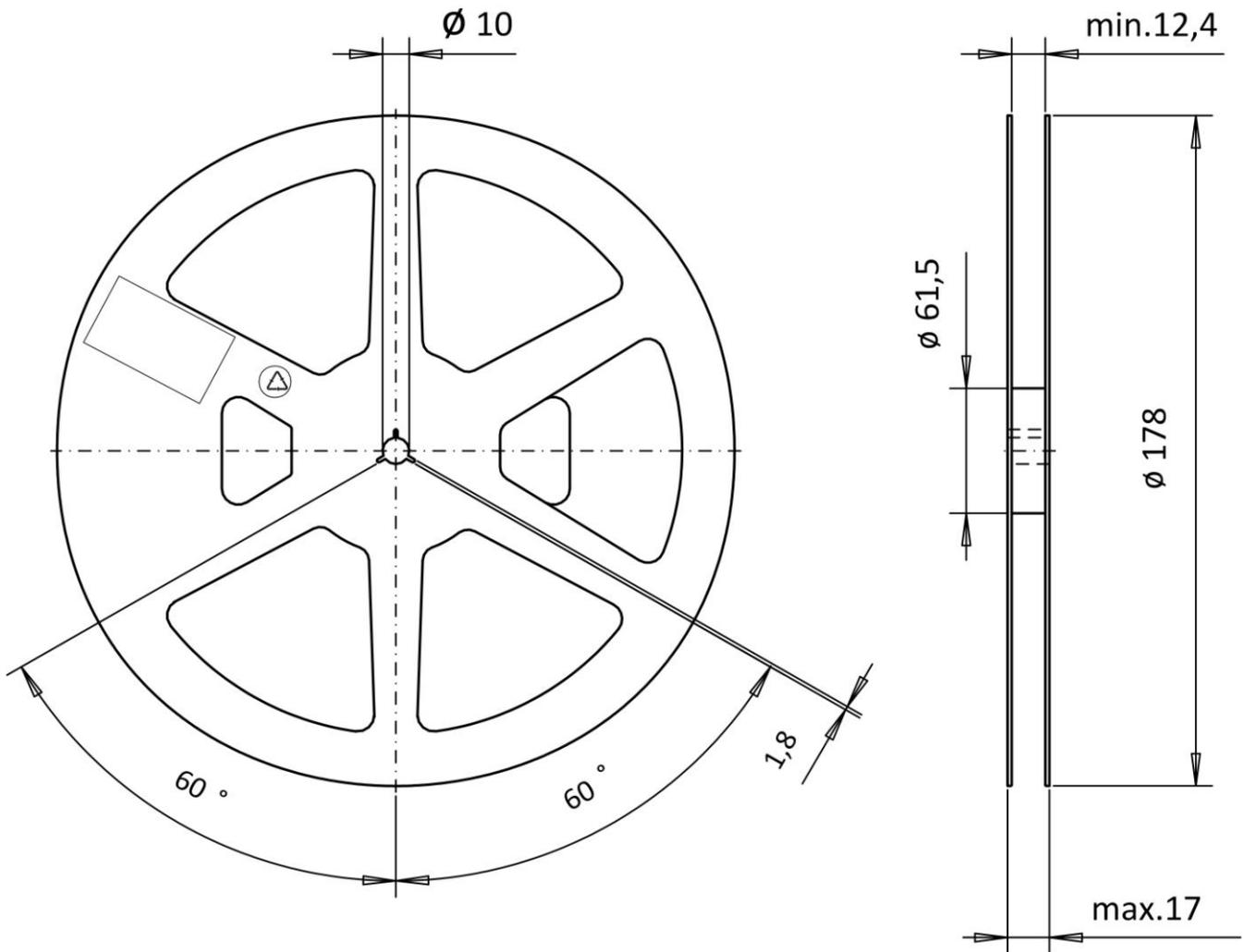

Reel:

Diameter	Material
7"	Plastic, Polystyrol



11. HANDLING PRECAUTIONS FOR CRYSTALS OR MODULES WITH EMBEDDED CRYSTALS

The built-in tuning-fork crystal consists of pure Silicon Dioxide in crystalline form. The cavity inside the package is evacuated and hermetically sealed in order for the crystal blank to function undisturbed from air molecules, humidity and other influences.

Shock and vibration:

Keep the crystal / module from being exposed to **excessive mechanical shock and vibration**. We guarantee that the crystal / module will bear a mechanical shock of 5000g / 0.3 ms.

The following special situations may generate either shock or vibration:

Multiple PCB panels - Usually at the end of the pick & place process the single PCBs are cut out with a router. These machines sometimes generate vibrations on the PCB that have a fundamental or harmonic frequency close to 32.768 kHz. This might cause breakage of crystal blanks due to resonance. Router speed should be adjusted to avoid resonant vibration.

Ultrasonic cleaning - Avoid cleaning processes using ultrasonic energy. These processes can damage crystals due to mechanical resonance of the crystal blank.

Overheating, rework high temperature exposure:

Avoid overheating the package. The package is sealed with a seal ring consisting of 80% Gold and 20% Tin. The eutectic melting temperature of this alloy is at 280°C. Heating the seal ring up to >280°C will cause melting of the metal seal which then, due to the vacuum, is sucked into the cavity forming an air duct. This happens when using hot-air-gun set at temperatures >300°C.

Use the following methods for rework:

- Use a hot-air- gun set at 270°C.
- Use 2 temperature controlled soldering irons, set at 270°C, with special-tips to contact all solder-joints from both sides of the package at the same time, remove part with tweezers when pad solder is liquid.

EM Microelectronic-Marin SA ("EM") makes no warranties for the use of EM products, other than those expressly contained in EM's applicable General Terms of Sale, located at <http://www.emmicroelectronic.com>. EM assumes no responsibility for any errors which may have crept into this document, reserves the right to change devices or specifications detailed herein at any time without notice, and does not make any commitment to update the information contained herein.

No licenses to patents or other intellectual property rights of EM are granted in connection with the sale of EM products, neither expressly nor implicitly.

In respect of the intended use of EM products by customer, customer is solely responsible for observing existing patents and other intellectual property rights of third parties and for obtaining, as the case may be, the necessary licenses.

Important note: The use of EM products as components in medical devices and/or medical applications, including but not limited to, safety and life supporting systems, where malfunction of such EM products might result in damage to and/or injury or death of persons is expressly prohibited, as EM products are neither destined nor qualified for use as components in such medical devices and/or medical applications. The prohibited use of EM products in such medical devices and/or medical applications is exclusively at the risk of the customer