



# MULTI-PROTOCOL BLUETOOTH 5.3 SOC AND COMPANION CHIP WITH FLASH

## General Description

The EM9305 is a tiny, ultra-low power and high performance Bluetooth 5.3 low energy chip.

Its highly flexible architecture allows it to act as a companion IC to any ASIC or MCU-based product, or as a complete System-on-Chip (SoC). Its flexibility also allows it to be used with other protocols. Custom applications can execute on an efficient 32-bit ARC processor from a 512kB flash using a cache and DMA to optimize power. DSP and floating-point units can be exploited to implement advanced audio and tracking. Low-power serial interfaces (SPI, I2C, I2S, and UART) can be used to talk with external sensors, memory, display, or touch drivers. In addition, EM9305 can directly be supplied by a USB port of a PC.

Included in software is a Bluetooth 5.3 link layer, Host Controller Interface (HCI), stack and profiles. High Data Rate (HDR) and Long Range (LR) communication are available on EM9305.

The EM9305 includes a sophisticated on-chip power management system supporting 1.5V or 3V batteries, and it can be directly powered from an attached 5V USB port. An inductor-less mode for 1.5V batteries can help further reduce the BOM. All 64kB of RAM memory can be kept in retention during sleep, or in 4kB increments to optimize leakage. A stable, low-power sleep oscillator minimizes power consumption while in a connected state or RTC operation. Current consumption is minimized for all modes of the application utilizing an efficient scheduler and memory manager.

The EM9305 features a state-of-the-art 2.4GHz transceiver: a low-power receiver with excellent sensitivity/selectivity, and a programmable transmitter for optimized output power and current consumption.

The PCB footprint and cost is minimized with a very low external component count and several package options. The circuit is offered in a WLCSP23 wafer level chip-scale package, a plastic QFN-28 package, and bare die/wafer form. The device and reference design are available over the industrial temperature range.

The highly capable hardware of EM9305 allows to do much more, and other features will be released regularly with SDK updates. Please contact EM Sales representative for more information.

## Key Features

- Energy efficient, industry standard, ARC EM7D, 32-bit MCU with DMA and Cache for minimum power consumption
- DSP and FPU for signal processing
- 64kB ROM for secure boot
- 512kB flash memory for protocol and applications
- 64kB data/instruction RAM, all retainable starting from 4kB
- 48MHz MCU and memory-read speed
- USB, UART, I2C, I2S/TDM and SPI serial interfaces
- 12 GPIO on QFN, 10 GPIO on WLCSP
- Bluetooth 5.3 Implementation and upgradable
- High Data Rate (HDR) and Long Range (LR) support
- SPI and UART HCI Transport Layers
- Security Features
  - True Random Number Generator
  - AES-128 Hardware Encryption/Decryption Engine
  - Key Generation (ECC-P256)
  - Secure Key Containers
  - Secure lifecycle management
- Sophisticated Power Management System
  - Digital step up/down DCDC operation supporting 1.1-3.6V
  - Inductor-less voltage multiplier mode for minimal BOM
  - Additional mode powered directly from 5V USB port
  - Low frequency RC oscillator time base
- Low Current Consumption at 3V
  - 3.0mA typical receiver current
  - 3.5mA typical transmitter current at 0dBm
  - 220nA in deep sleep mode (no RAM retention)
  - 7nA in disable mode
- High Performance RF
  - 94/-97/-103dBm RX sensitivity for 2Mbps/1Mbps/125kbps modes and 37 byte payload
  - 57dBm to +6dBm transmitter output power range
- Low Component Count and Cost:
  - Single ended antenna pin with matching network
  - Minimal DC component network
  - 48MHz XTAL
  - QFN-28 (4x4mm), WLCSP23 (1.8x1.8mm), and bare-die/wafer
- Operating temperature: -40°C to +85°C

## APPLICATIONS

Bluetooth Low Energy applications such as:

- | Beacons
- | Positioning
- | Logistic tracking
- | Wearables and Sports Equipment
- | Healthcare Monitoring
- | Remote Sensing
- | Motion and Tracking Devices
- | Home Automation
- | Light Control Applications
- | Smart cities
- | Wireless Mice and Keyboards
- | Alarms and Security System
- | Toys

Enabled by the mobile phone as access point to the Internet

## CUSTOMER SUPPORT

- | Hardware and PCB design
- | Firmware development, software development kits
- | FCC/CE certification support
- | Forum for hardware and software support

## TYPICAL APPLICATION DIAGRAMS

The EM9305 is the ideal Bluetooth Low Energy companion for any MCU or ASIC application, as illustrated in Figure 0-1. It may be easily connected with:

- | standard 3V MCU's within the very rich catalog of any microprocessor vendor,
- | standard 1.5V MCU's such as ultra-low-power watch microprocessors from EM Microelectronic,
- | any custom sensor processing ASIC for customers requiring a simple add-on function.

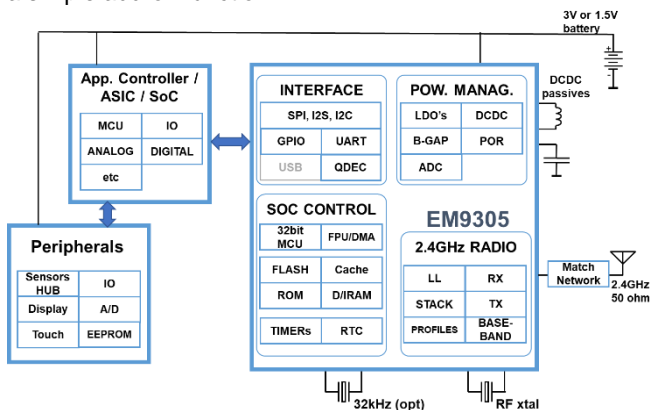
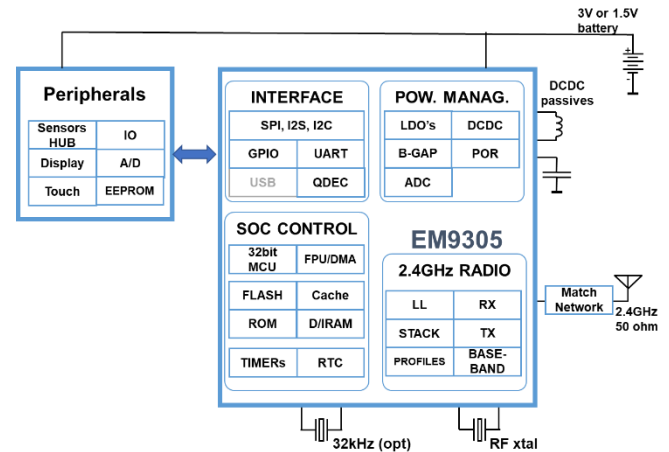

**Figure 0-1: Typical application schematic – Bluetooth Low Energy Companion IC to any MCU or ASIC**

The EM9305 is a flexible solution which may also be used without an external MCU for simple applications such as beacons. As illustrated in Figure 0-2, it may be directly connected to external digital sensors which may exploit the EM9305's internal 32-bit processing capability, or with sensor hubs such as from EM's SENtral platform.

Other applications using A/D converters, display and/or touch interfaces can also be implemented.

The EM9305 can be supplied from a 3V battery (e.g. Lithium coin-cell). In such case, the DCDC converter is put into step-down configuration. The EM9305 can also be supplied from a 1.5V battery (e.g. Alkaline, Silver-Oxide, or Zinc-Air single cells). In such case, the DCDC converter is put into step-up configuration.



**Figure 0-2: Typical application schematic – EM9305 in SOC mode connected with peripherals**

Finally, configurations are also possible without the DCDC converter (no inductor required), for systems already with power management, or for systems that require the lowest bill of materials.