

EMDK85xx DEVELOPMENT KIT USER GUIDE

TABLE OF CONTENTS

1	INTRODUCTION	2
2	MAIN FEATURES	2
3	CONTENT DESCRIPTION	3
4	INSTALLATION AND SOFTWARE/FIRMWARE UPDATE	3
4.1	INITIAL INSTALLATION	3
4.2	SOFTWARE UPDATE	9
4.3	FIRMWARE UPDATE	10
5	HARDWARE DESCRIPTION OVERVIEW	12
5.1	CONFIGURATION MODE	13
5.2	APPLICATION MODE	14
5.3	STAND-ALONE MODE	15
6	APPLICATION INTERFACE	17
7	APPLICATION BOARD	18
7.1	DESCRIPTION	18
7.2	SCHEMATIC	20
7.3	BOM	21
7.4	INTERNAL MEASUREMENT: A/D ACQUISITION UNIT	22
8	DAUGHTER BOARD	23
8.1	OVERVIEW	23
8.2	INTERNAL MEASUREMENT: A/D ACQUISITION UNIT	25
8.3	EXTERNAL MEASUREMENT BY SHUNT RESISTORS	25
8.4	CONNECTIONS FOR EXTERNAL HRV MEASUREMENTS	26
8.5	CONNECTIONS FOR EXTERNAL LTS MEASUREMENTS	27
8.6	CONNECTIONS FOR EXTERNAL STS MEASUREMENTS	28
9	BASE BOARD	29
9.1	OVERVIEW	29
10	EM8500 DEVELOPMENT EXPLORER USER INTERFACE	31
10.1	CONFIGURE MENU DESCRIPTION	32
10.2	MEASURE WINDOW DESCRIPTION	33
10.3	VISUALIZE WINDOW DESCRIPTION	35
10.4	MEASURE AND VISUALIZE WINDOWS - ACQUISITION UNIT INFORMATIONS	37
11	TABLE OF CONTENTS	39
11.1	LIST OF FIGURES	39
11.2	LIST OF TABLES	40

1 INTRODUCTION

The EM85xx naming shall be used in this document as a generic part number name for EM85xx devices.

The EMDVK85xx naming shall be used in this document as a generic part number name for EM85xx development kit.

The EMDVK85xx is a powerful development kit for the configuration, evaluation, prototyping and measurement of integrated energy harvesting solutions based on EM85xx devices.

The development kit offers a complete set of features to characterize and configure your hardware application.

The EMDVK85xx consists of three boards:

- The Base board
- The EMDVK85xx daughter board
- The application board

The EMDVK85xx exists in different variants in order to support the EM8500 different devices (e.g EM8500, EM8502,...).

Note: The electronic board designated as “application board” is referenced in this document. The “application board” may no longer be included in the most recent versions of the development kit. As this product has been discontinued, some kits may be delivered without “application board”

2 MAIN FEATURES

Hardware

- | Modular architecture for prototyping, test and customer application
- | Flexible load and harvester source selection
- | Ready to measure nodes for lab equipment (oscilloscope, power analyzer, ...)
- | Up to eight channel high speed acquisition
- | Expansion header for prototyping and external connection
- | Application board
- | On-board EM8500 configuration
- | EM8500 registers and EEPROM configuration
- | Self USB powered and stand-alone mode

Software

- | Friendly GUI
- | Multi-window environment
- | User friendly graphical interface
- | Register and EEPROM view and configuration
- | Configurable connection matrix
- | Support for I2C and SPI access
- | Selectable operation modes
- | Advanced real-time energy voltage profile recording
- | Waveform display
- | Cursors and zooming capabilities
- | Monitoring and advanced measurement

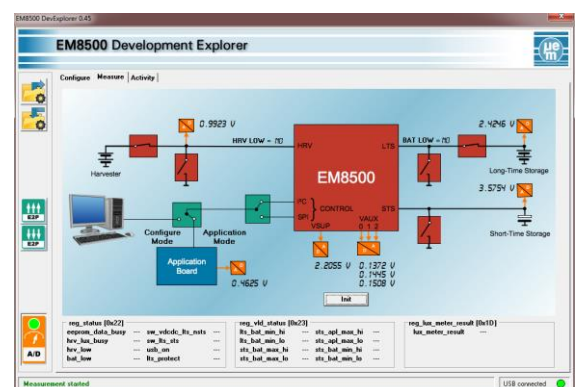

3 CONTENT DESCRIPTION

The EMDVK85xx kit consists of:

- | 1x Base board
- | 1x Daughter board
- | 1x Application board
- | 1x Memory stick - USB dongle 4GB containing EM8500 DevExplorer software installation setup
- | 1x Cable - USB cable type A to B
- | 1x Power supply - AC/DC +5V plug
- | 1x Solar cell

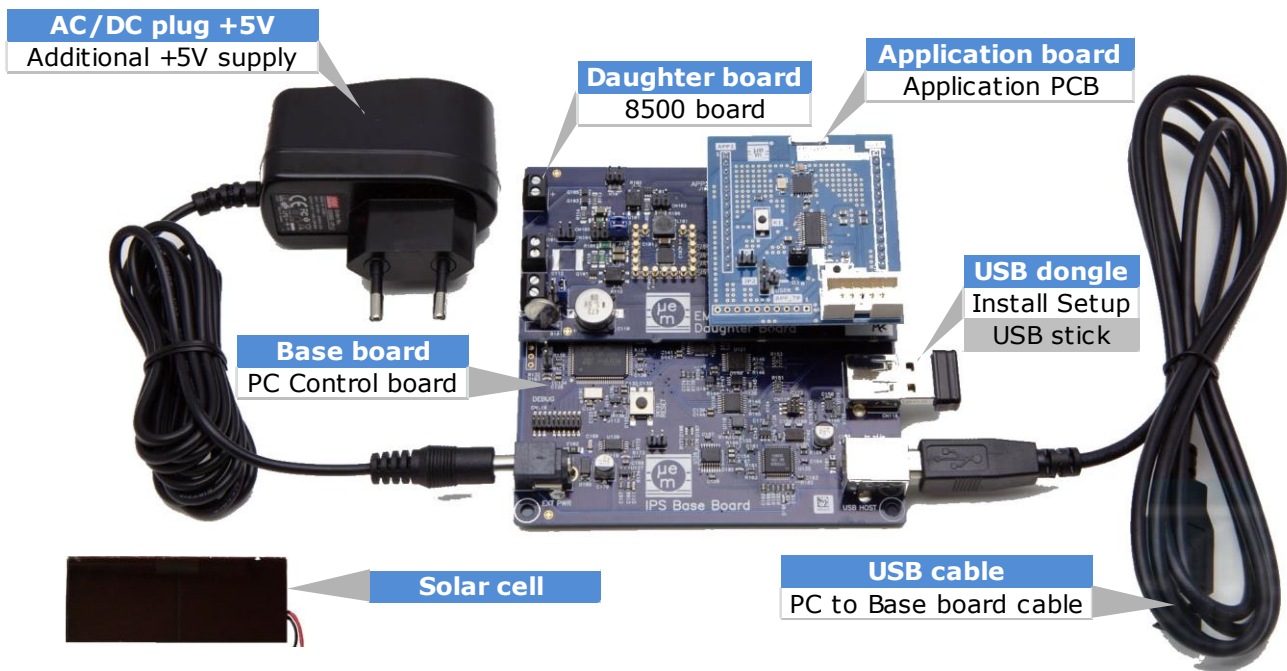

Figure 3-1 EMDVK8500 deliverables

4 INSTALLATION AND SOFTWARE/FIRMWARE UPDATE

4.1 INITIAL INSTALLATION

To install the software EM8500 DevExplorer, an installation setup file is available on the memory stick.

Simply **connect the memory stick** to the Base board (USB MEM connector) and **connect the Base board** (USB Host) to the PC through the USB cable.

Skip and **close** the installation driver window that may pop-up.

Open an **explorer** window

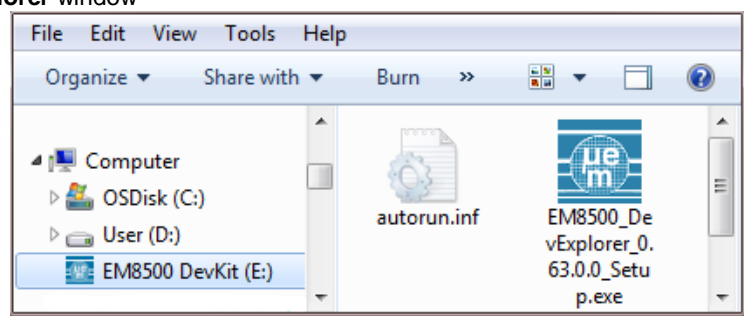

Click on the relevant **USB stick drive** (EM8500 DevKit)

Double click on the **EM8500 DevExplorer setup executable file** and accept the installation invitation.

The following installation wizard appears. Click **Next**.

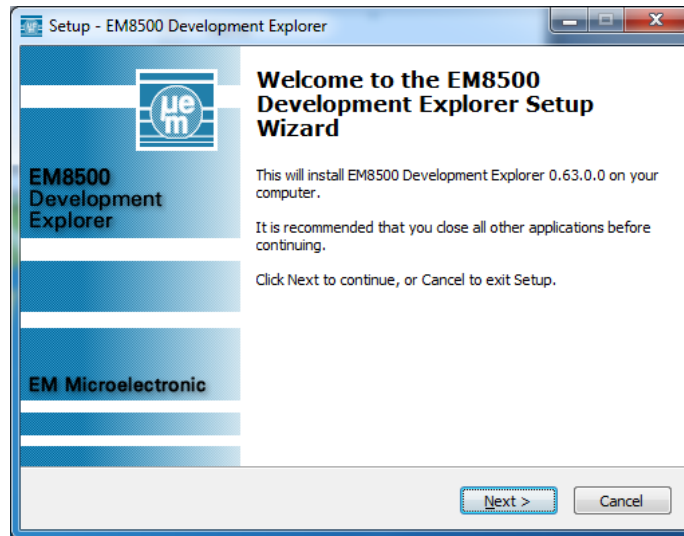

You can answer **No** to the following question and check for update later.

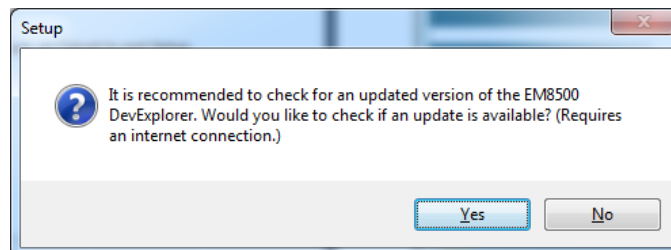

Accept the license agreement (**Next**)

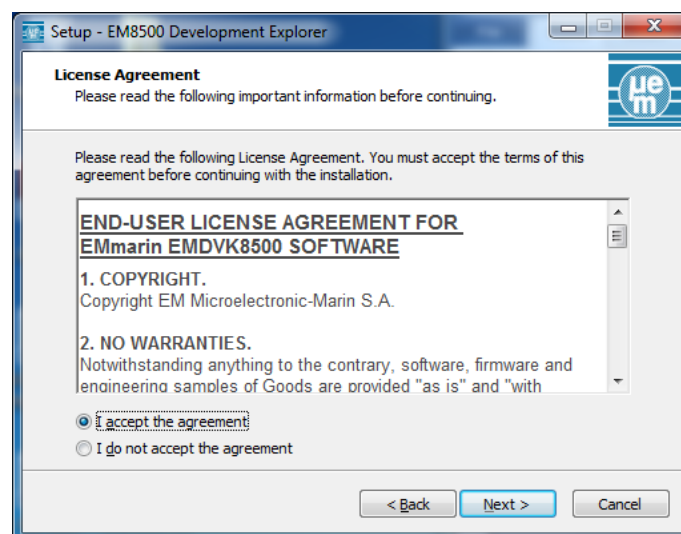

Choose your installation folder path then click **Next**.

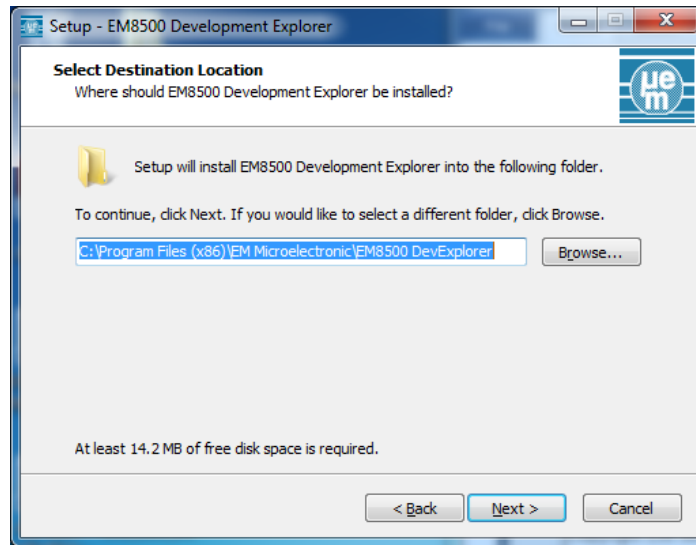

Choose your shortcuts then click **Next**

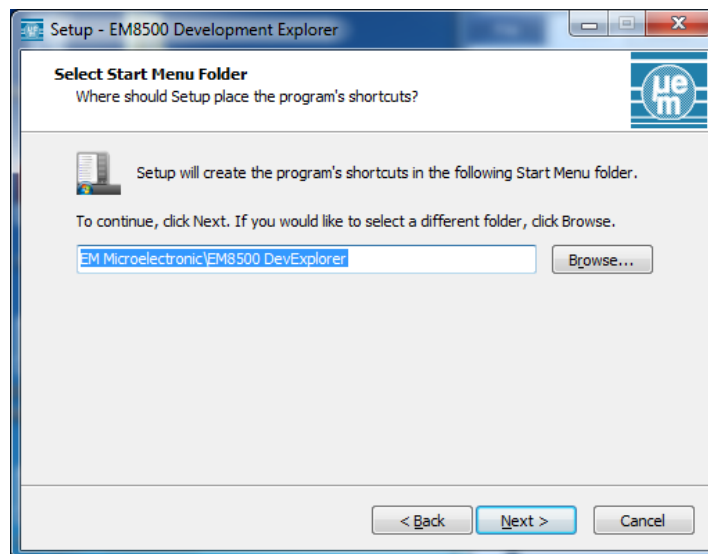

Select the **FTDI USB driver** installation and click **Next**

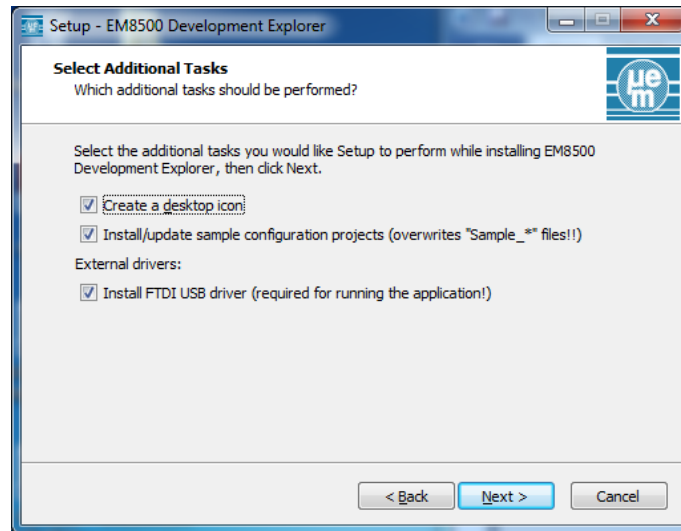

Then install the FTDI driver.

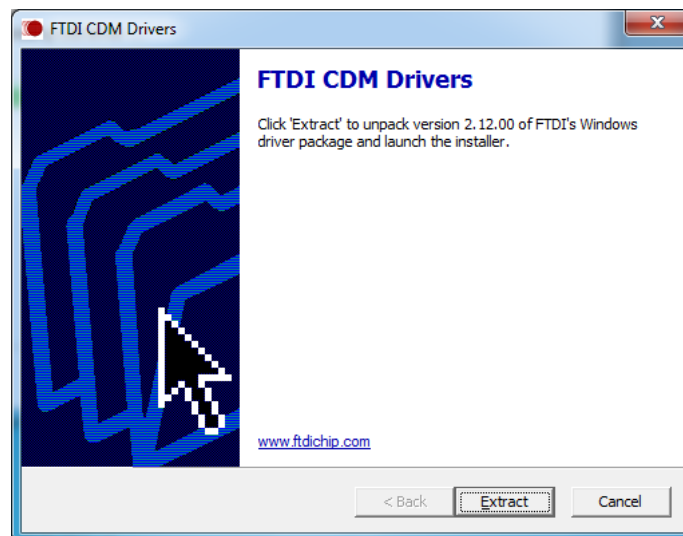

Once the FTDI driver installed, the installation is **complete**.

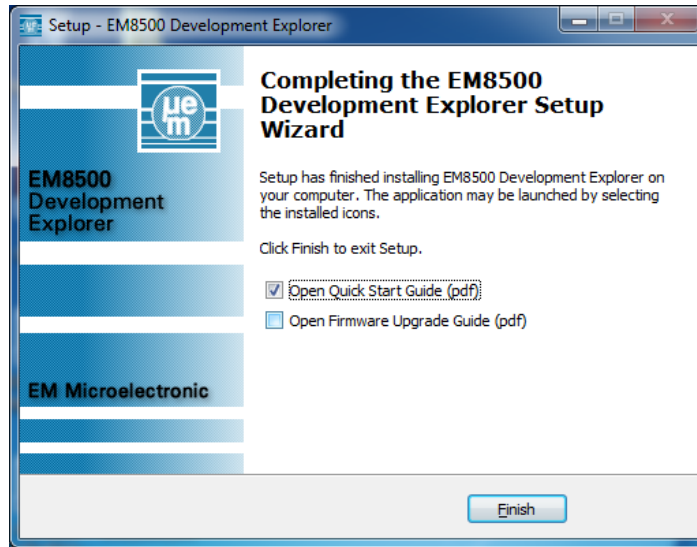

After installation, the Start Menu now contains the following shortcuts

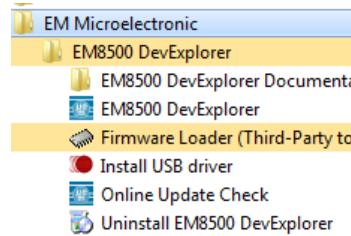

From this Menu, two update tools are available.

- | The shortcut **Online Update Check** is used to check for new EM8500 DevExplorer software release. Use this shortcut to check for updates.
- | The shortcut **Firmware Loader (Third-Party tool)** is used to update the firmware of the Base board.

Each EM8500 DevExplorer software contains a programming Hex file for the Base board firmware. Use this shortcut to do the firmware update if required

Note:

In case you decide to directly check for an update during your initial installation (answering yes to the below message requires that your PC has an active **internet connection**), the following message will be displayed.

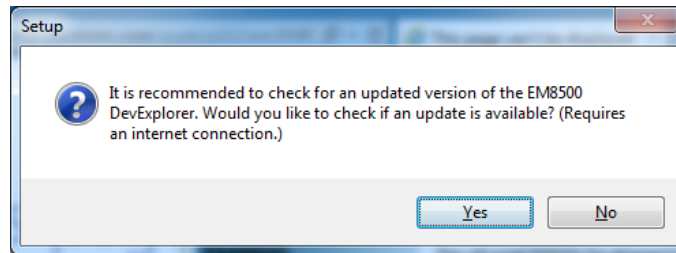

Click **Yes**.

In the below installation example, an update has been found.

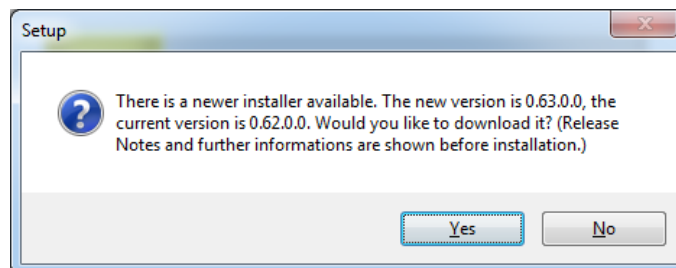

Click **Yes**.

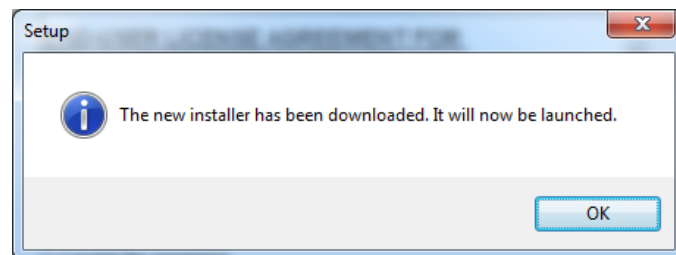

Then the normal procedure installation needs to be followed. Click **OK** and follow the normal installation flow.

4.2 SOFTWARE UPDATE

EM8500 DevExplorer features an Online Update check that allows checking and installing available updates. To obtain the latest version, use the shortcut "OnLine Update Check" from the EM8500 DevExplorer.

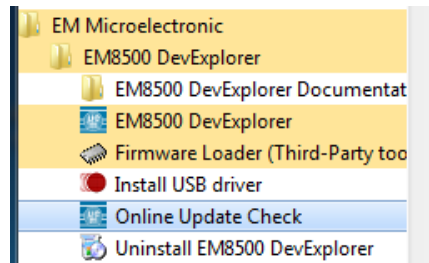

DevExplorer starts checking for updates and downloads them automatically. If a more recent version is available, the following message will be displayed. Click **Yes**

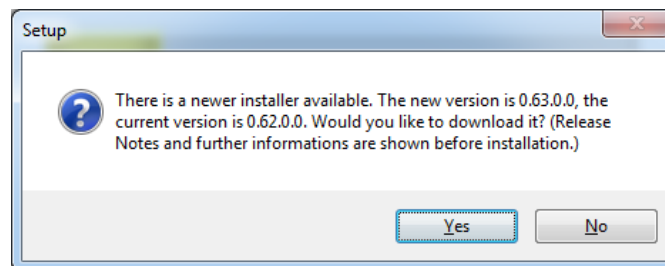

Once the download is done, the normal procedure installation needs to be followed. Click **Yes** and follow the normal installation flow.

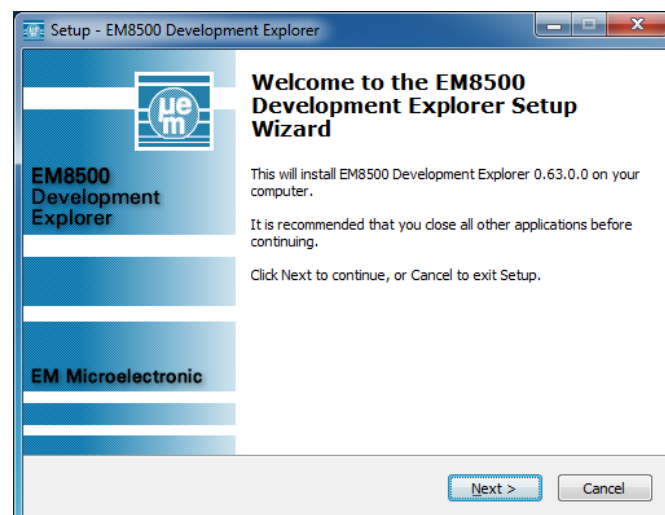
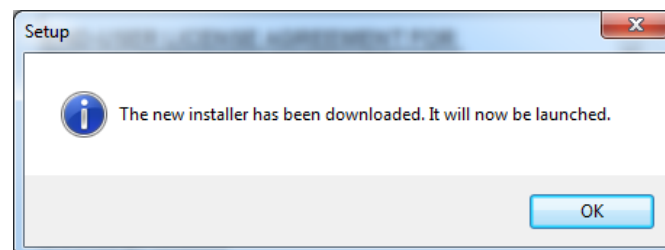

4.3 FIRMWARE UPDATE

If it isn't installed, run the EM8500 DevExplorer setup and plug in the hardware at least once, so drivers are installed. The installer has created a firmware directory for you, from which all subsequent steps shall be performed.

Note:

Firmware loader requires installation of MS Visual C++ Libraries which are commonly installed on PCs. If these are not installed on your PC, you may either download them from Microsoft or install the full Flash Loader Demonstrator package from ST Microelectronics, part number STSW-MCU005

Follow the steps below to update the firmware.

- | Confirm that the DevExplorer is closed.
- | Navigate to the EM8500 DevExplorer start menu entries.
- | Click on “Firmware Loader (Third-Party tool)” “Flash Loader” to start this tool
- | All settings except the COM port are already preset. To identify the correct COM port, use the Device Manager and check the corresponding “USB Serial Port (COM x)” used.

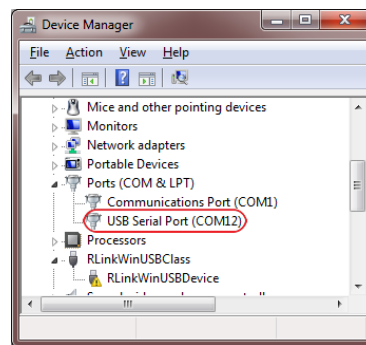

Select the correct port from the drop-down-field Port Name:

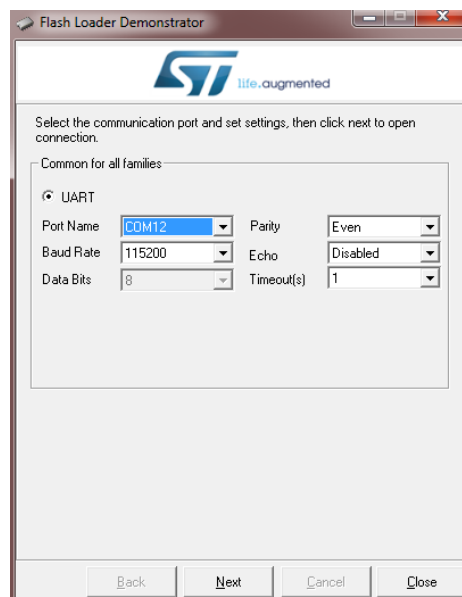

On the Base board:

- | place the BOOT jumper J108 to select the controller's boot mode **(1)** and
- | press the RESET button SW101 - **(2)**.
- | The green status LED D103 stops flashing while in boot mode **(3)**

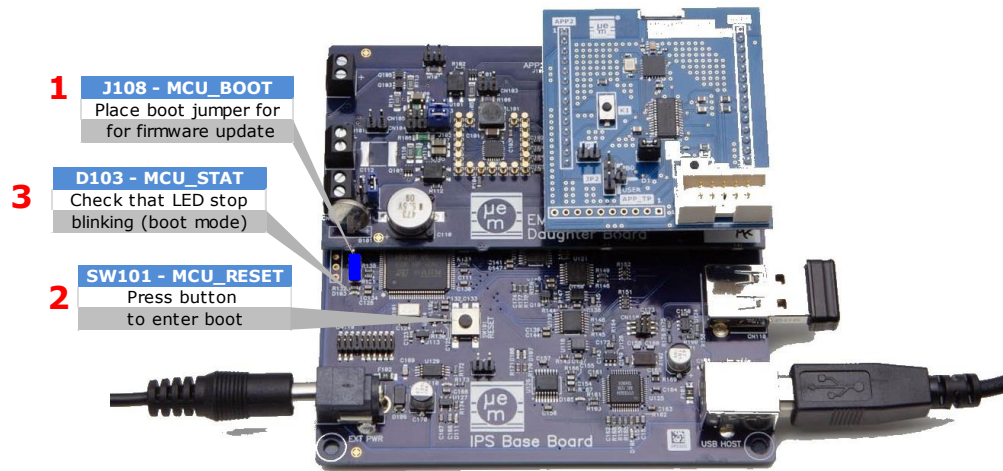

Figure 4-1 Configure boot mode (firmware update)

- | The flash loader tool will guide you through the firmware download process.

It's not recommended to change the pre-configured settings. In case of errors, press the Base board RESET button SW101 again (with the BOOT jumper placed) and navigate back to the communication selection tab and retry.

- | After successfully downloading the new firmware click "Close" to exit the flash loader tool.
- | Remove the BOOT jumper and power-cycle the Base board.

5 HARDWARE DESCRIPTION OVERVIEW

The EMDVK85xx exists in different variants to support each device of the EM85xx family. In this document without specific description the name 8500 in the different figures applies for any member of the EM85xx family. Some particular description refers to specific parts (e.g. EM8500, EM8502,...).

The architecture of the EMDVK85xx is based on the following block diagram

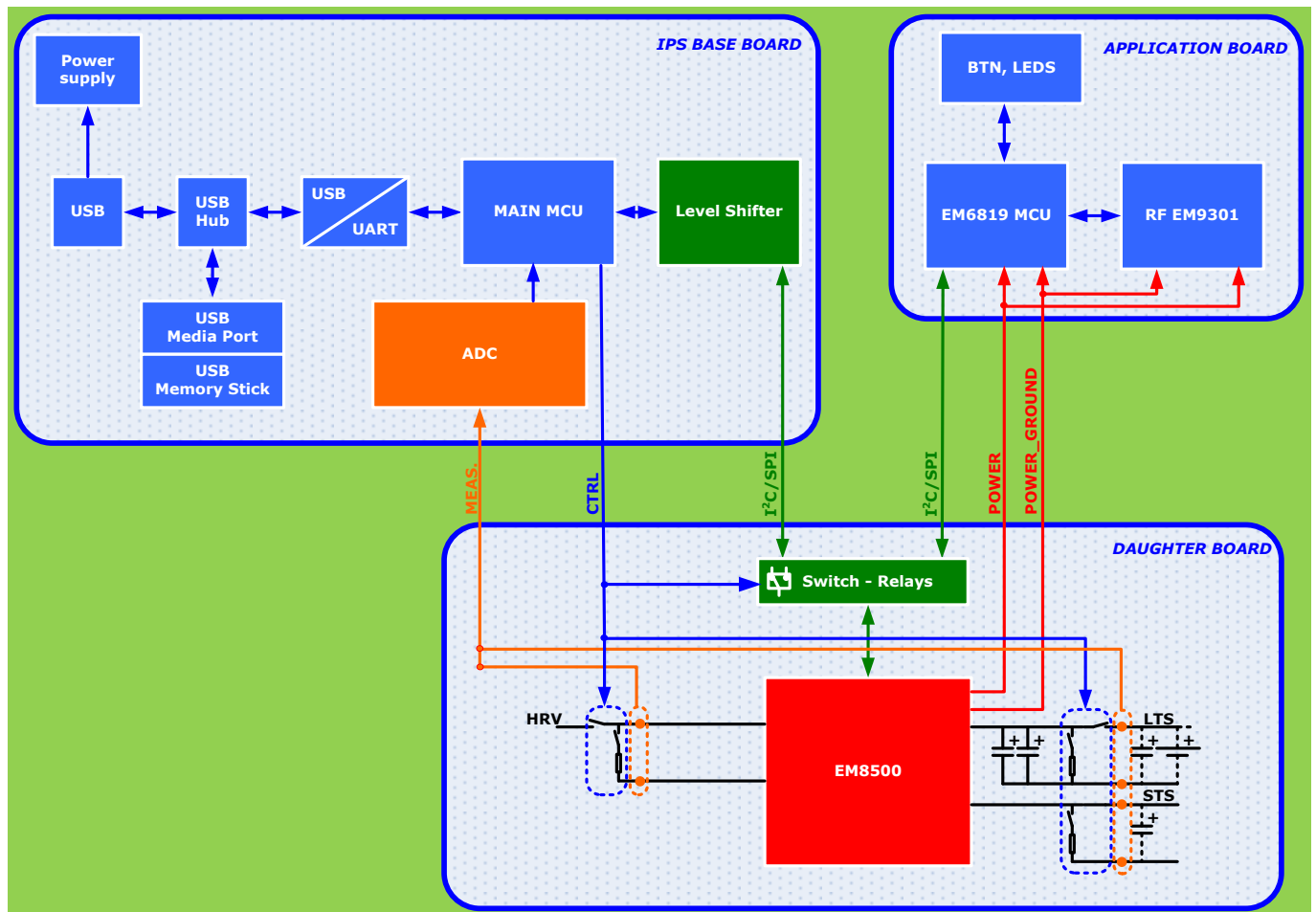

Figure 5-1 EMDVK85xx System Architecture

The Base board connects the PC to the EMDVK85xx daughter board through USB. The Base board contains a microcontroller (Main MCU) to perform several tasks:

- | Communication to the PC (USB)
- | Communication to the EM85xx (support for I²C and SPI bus)
- | ADC acquisition (MEAS.)
- | Switch and relay control (CTRL)

The EMDVK85xx daughter board is the core of the harvesting system based on the EM85xx device. It features:

- | Switches for connecting the harvester source (HRV), the storage elements (Short Term Storage STS - Long Term Storage LTS)
- | Connections to the loads (POWER and POWER_GROUND).
- | Some access to the voltage nodes monitored by MEAS.
- | Multiple access to the different nodes of the system and shunt resistors (for current or power analysis) for HRV, LTS and STS
- | Jumpers for configuration

- | On board default HRV, STS and LTS with spare position (STS)
- | Additional expansion connector to connect external HRV, STS and LTS.

The application board is the application load of the system. The application board implements an EM6819 8-bit low-power microcontroller, an EM9301 2.4Ghz Bluetooth Low Energy Controller, push-buttons and LEDs able to implement various types of low-power applications. The application board can also be removed and replaced by another application board or the user can connect external elements to the application headers.

Due to its modular architecture and flexible design, the EMDVK85xx is a very versatile system and as such offers a lot of possibilities to the user. The following operating modes are offered to the user:

5.1 CONFIGURATION MODE

In this mode the Base board is connected to and powered from the PC over the USB connection. The EM85xx SPI/I²C interface is connected to the Base board Main MCU and the Base board can access the EM85xx registers. The application board is disconnected from the EM85xx lines (Application board doesn't need to be present). In this mode the ADC acquisition can be performed.

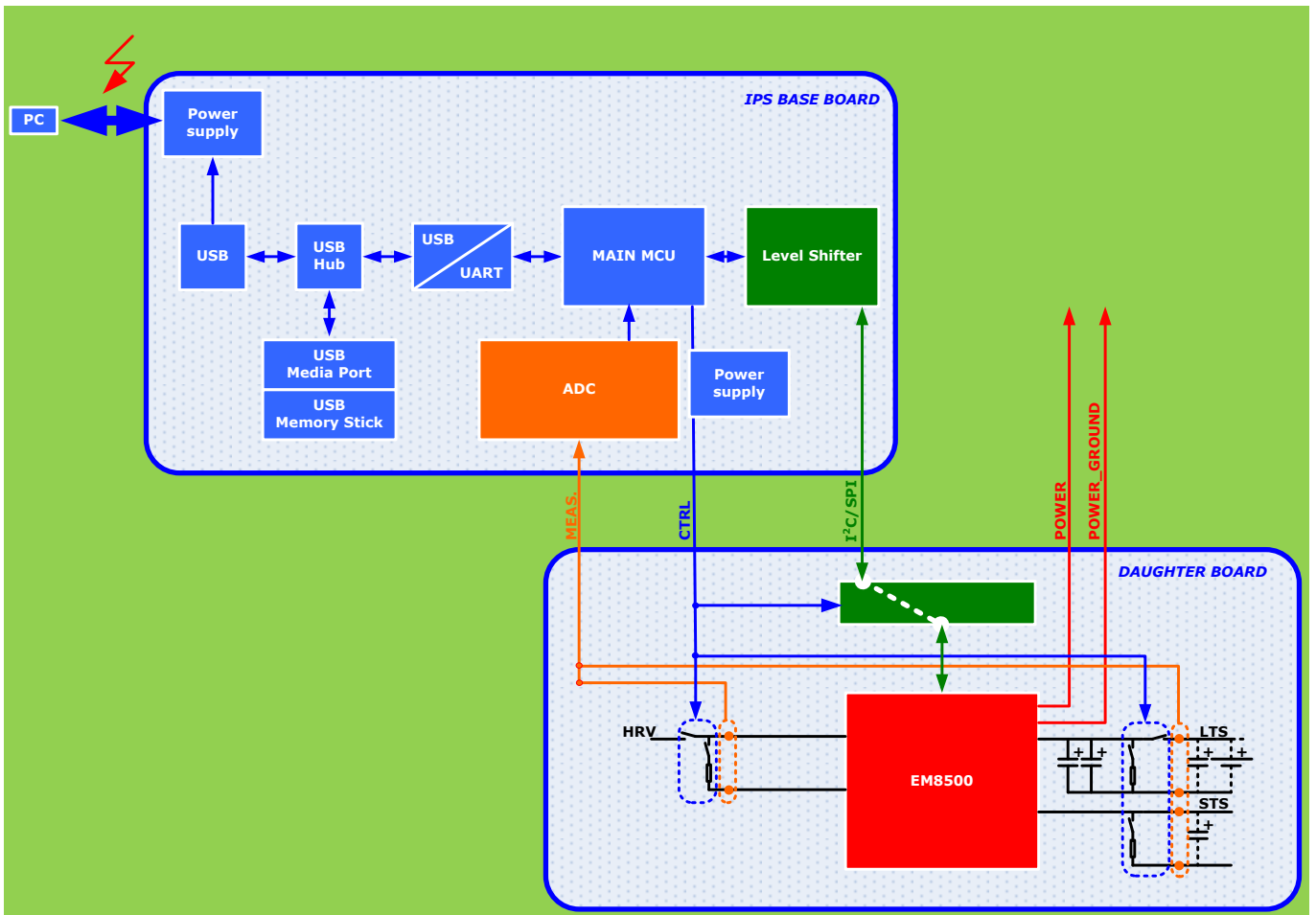

Figure 5-2 EMDVK85xx Configuration Mode

5.2 APPLICATION MODE

In this mode the Base board is connected to and powered from the PC over the USB connection. The EM85xx SPI/I²C interface is connected to the application board and the EM85xx lines are not connected to the Base board Main MCU. In this mode the ADC acquisition can be performed.

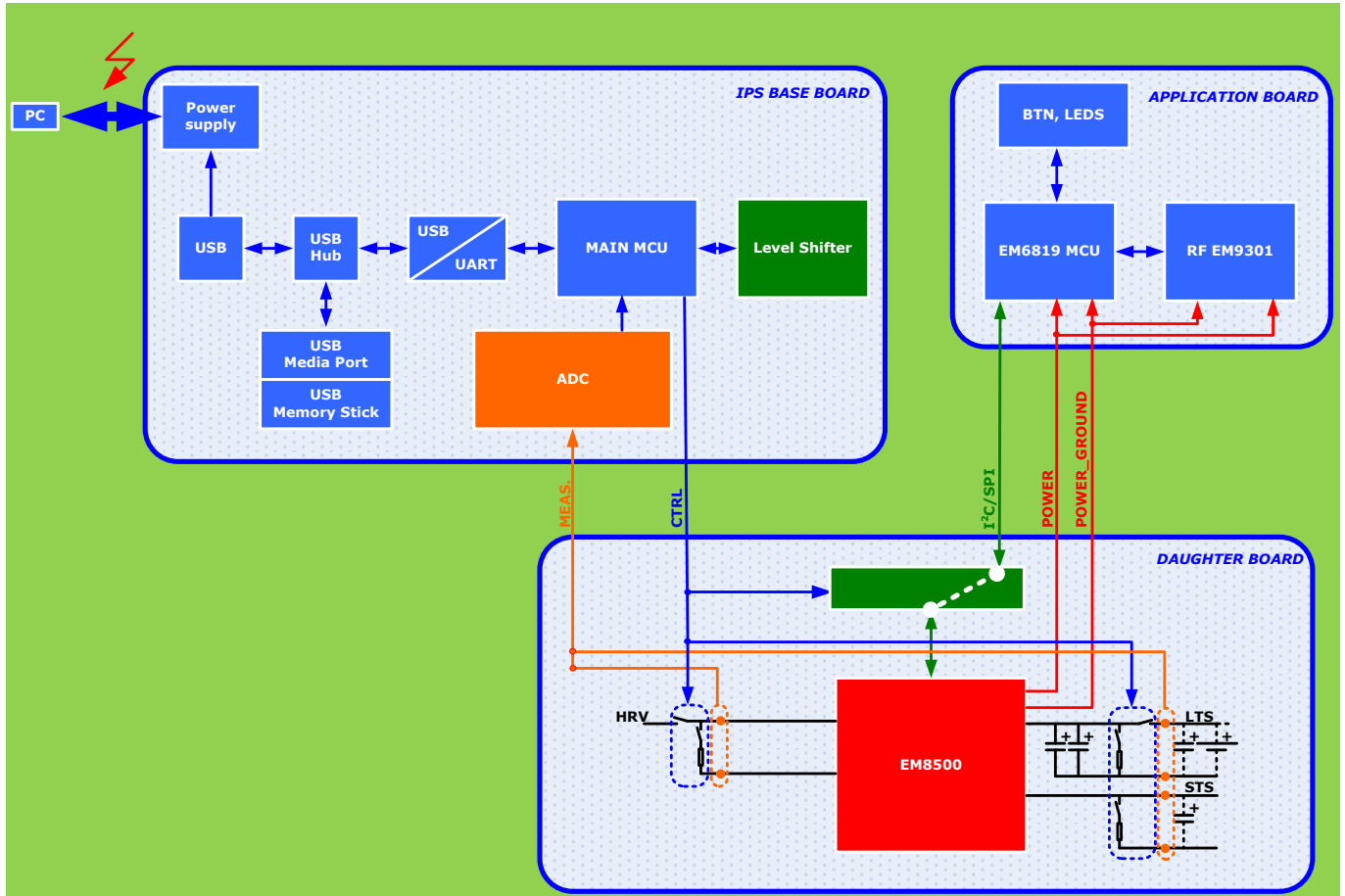

Figure 5-3 EMDVK85xx Application Mode

5.3 STAND-ALONE MODE

In this mode the Base board is not powered from the PC (no USB over the USB connection) or is even detached from the other two boards. . The EM85xx SPI/I²C interface is connected to the application board. The application is running. In this mode ADC acquisitions are not performed.

The corresponding mode is shown on the Figure 5-4 EMDVK85xx Stand-alone Mode with default application board.

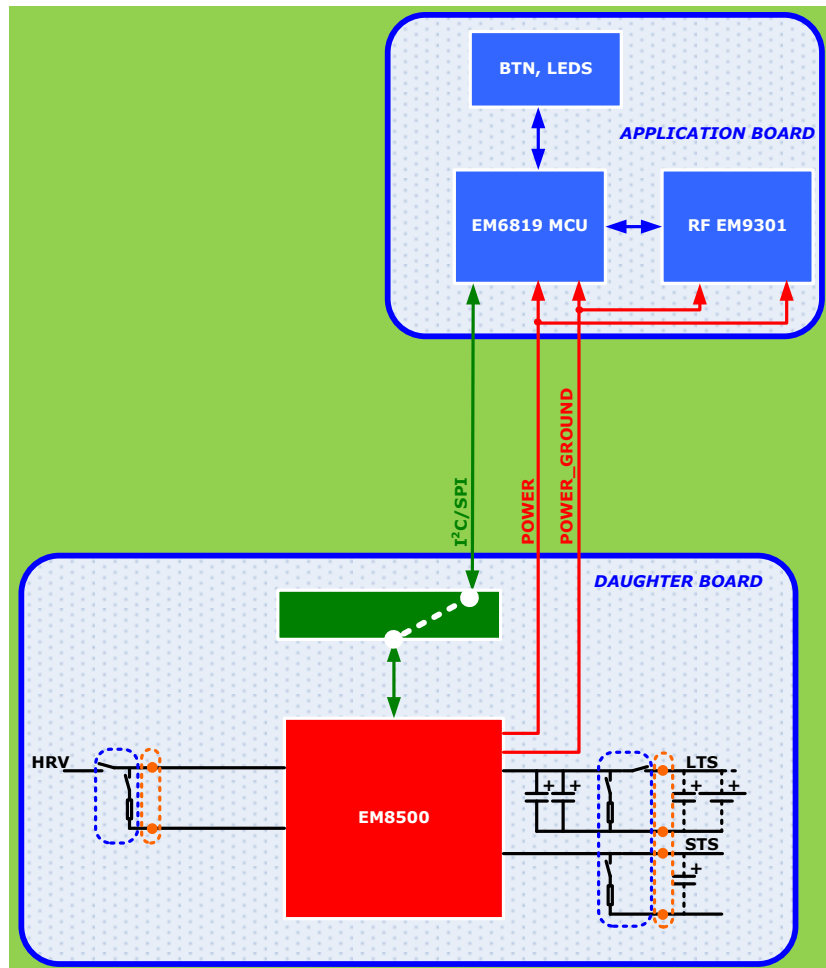

Figure 5-4 EMDVK85xx Stand-alone Mode with default application board

The other application mode option is the application board without default application board. The user directly accesses the application header available on the daughter board. The corresponding mode is shown on the Figure 5-5 EMDVK85xx Stand-alone Mode with user application connections.

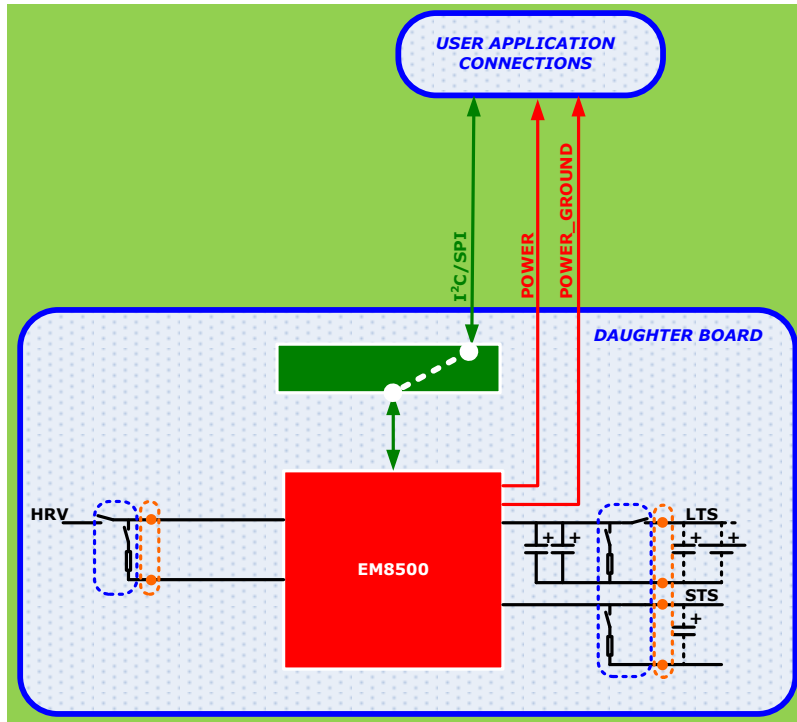

Figure 5-5 EMDVK85xx Stand-alone Mode with user application connections

6 APPLICATION INTERFACE

The application connector APP1 (J104) and APP2 (J107) provides all the connections for the application.

The application board can be connected to APP1 and APP2 or the user can access the connectors APP1 and APP2 and its test points.

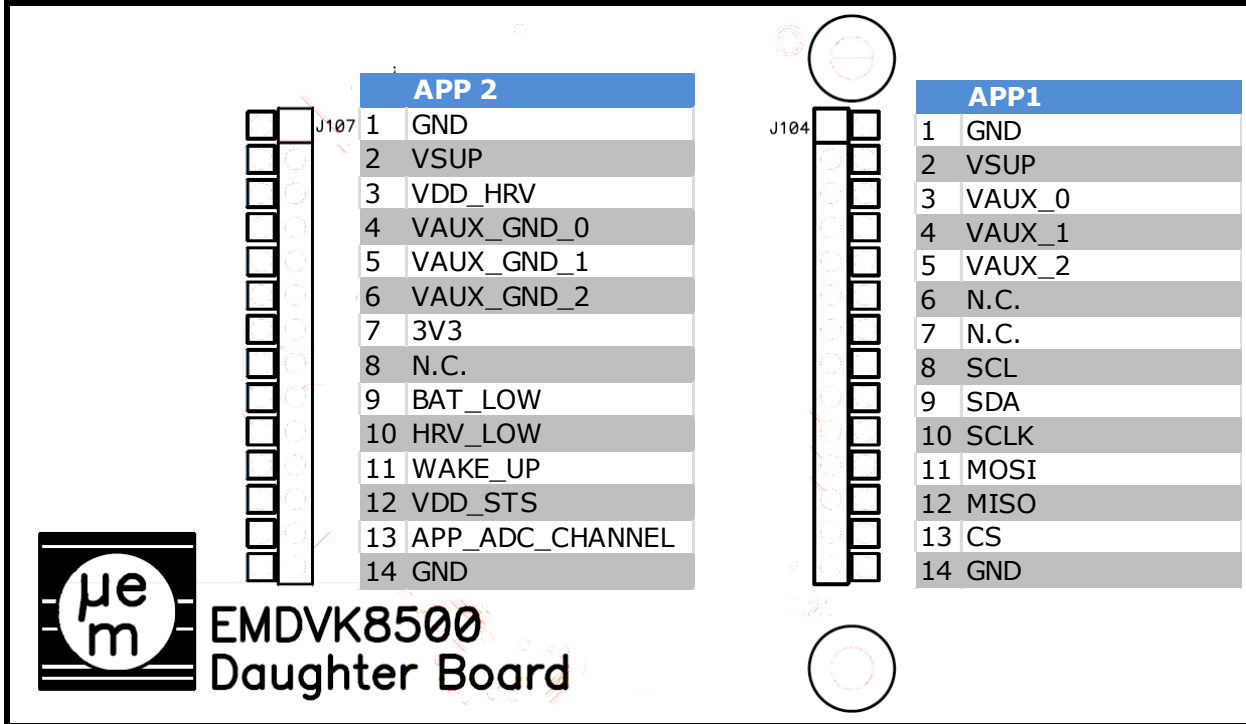

Figure 6-1 EMDVK85xx Daughter board – application connections APP2 (J107) and APP1 (J104) - top view

NO.	PIN NAME	I/O TYPE		DESCRIPTION
		DIRECTION ^(*)	SUPPLY	
1	GND	Supply	-	System ground connection (EM8500 device ground)
2	VSUP	Input	-	Main supply
3	VAUX[0]	Input	-	Auxiliary 0 supply input connection
4	VAUX[1]	Input	-	Auxiliary 1 supply input connection
5	VAUX[2]	Input	-	Auxiliary 2 supply input connection
6	N.C.			Reserved
7	N.C.			Reserved
8	SCL ^(*)	Output	VSUP	I ² C clock connection
9	SDA ^(*)	Inout	VSUP	I ² C data connection
10	SCLK ^(*)	Output	VSUP	SPI clock connection
11	MOSI ^(*)	Output	VSUP	SPI MOSI connection
12	MISO	Input	VSUP	SPI MISO connection
13	CS	Output	VSUP	SPI chip select and SPI/I ² C selection mode (when at '1')
14	GND	Supply	-	System ground connection (EM8500 device ground)

Table 6-1 APP1 Pin-out description

(*): DIRECTION is defined from the application point of view

(*): Pin 8 (SCL I²C clock) and Pin 10 (SCLK SPI clock) are connected together on the Base board.

(*): Pin 9 (SDA I²C data) and Pin 11 (MOSI SPI data) are connected together on the Base board.



NO.	PIN NAME	I/O TYPE		DESCRIPTION
		DIRECTION(*)	SUPPLY	
1	GND	Supply	-	System ground connection (EM8500 device ground)
2	VSUP	Output	-	Main supply Output
3	VDD_HRV	Output	-	Connection to the energy harvester
4	VAUX_GND[0]	Input	-	Auxiliary 0 ground connection
5	VAUX_GND[1]	Input	-	Auxiliary 1 ground connection
6	VAUX_GND[2]	Input	-	Auxiliary 2 ground connection
7	3V3	Input	-	+3.3V voltage
8	N.C.			Reserved
9	BAT_LOW	Input	VSUP	Battery low indicator (when at '1')
10	HRV_LOW	Input	VSUP	Energy harvester cell low indicator (when at '1')
11	WAKE_UP	Output	All	Wake-up pin
12	VDD_STS	I/O	-	Connection for the Short Term energy Storage element
13	APP_ADC_CHANNEL	Output	-	Application output for ADC channel acquisition
14	GND	Supply	-	System ground connection (EM8500 device ground)

Table 6-2 APP2 Pin-out description

(*): DIRECTION is defined from the application point of view

7 APPLICATION BOARD

7.1 DESCRIPTION

A default Application Board is provided with the EM8500 development kit.

The board is equipped with:

- | An 8-bit low power microcontroller EM6819F6-B300 in package TSSOP28.
- | A Bluetooth smart controller, 2.4Ghz RF balun and chip antenna
- | 2 push-buttons
- | 2 LEDs
- | Access to different nodes for ADC measurements
- | Application headers APP1 and APP2 and APP_TP

The board dimensions are 50 x 55.3 mm. APP1 and APP2 are Headers with 14 pins each (2.54 mm pitch).

Based on the default application board features, some low power application can be developed. With the on-board EM9301 wireless device some Bluetooth smart beacon applications can be implemented.

For the details concerning the EM9301 and the EM6819F6-B300, please refer to the corresponding datasheets.

The EM6819 can be programmed and debugged through the X1 connector (GASP connector). To develop EM6819 firmware, load firmware or debug EM6819 firmware the EM6819 development tools need to be used. Contact EM Microelectronic for more information or visit the EM Microelectronic Marin website <http://www.emmicroelectronic.com>.

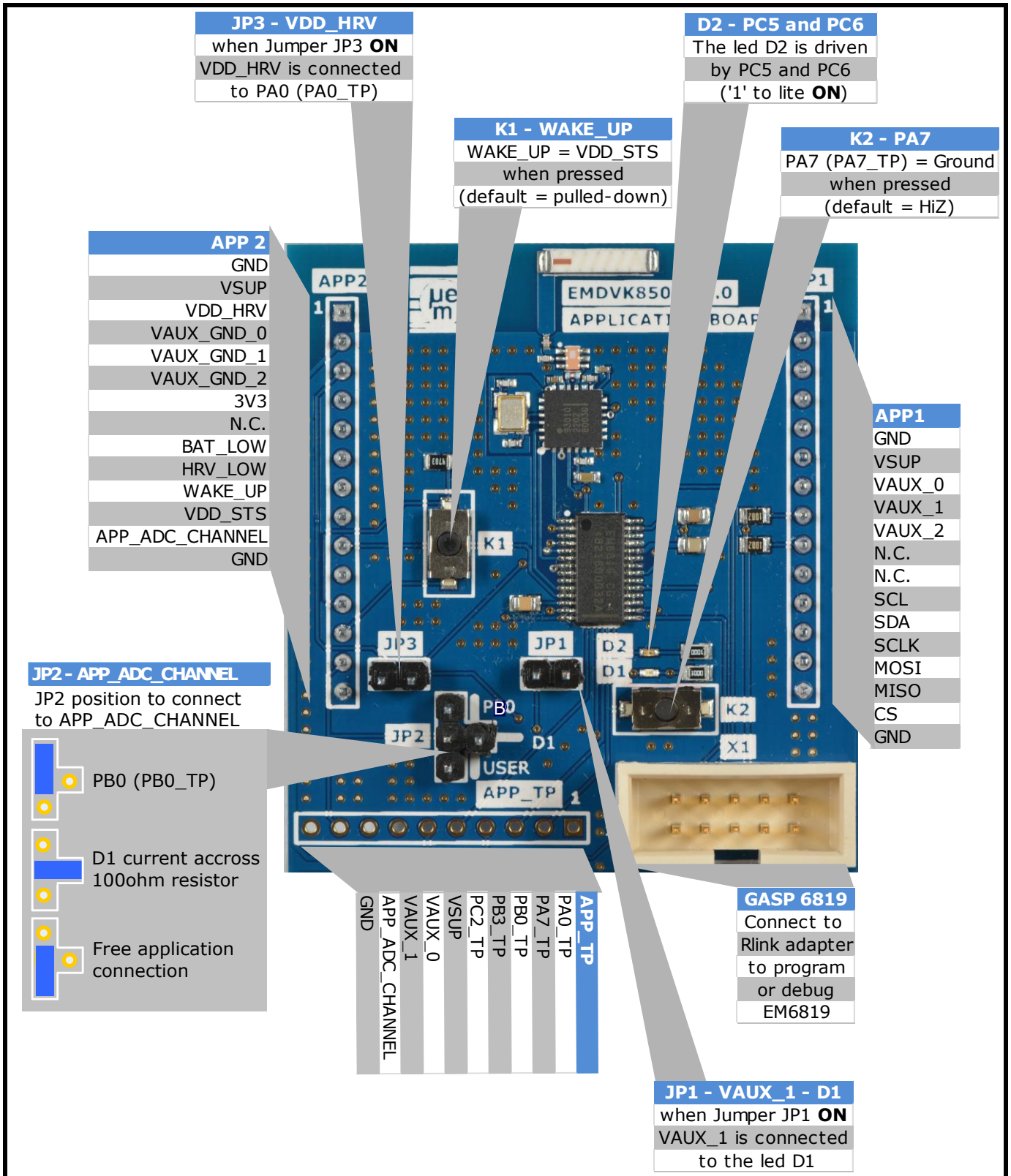

Figure 7-1: Application board description

7.2 SCHEMATIC

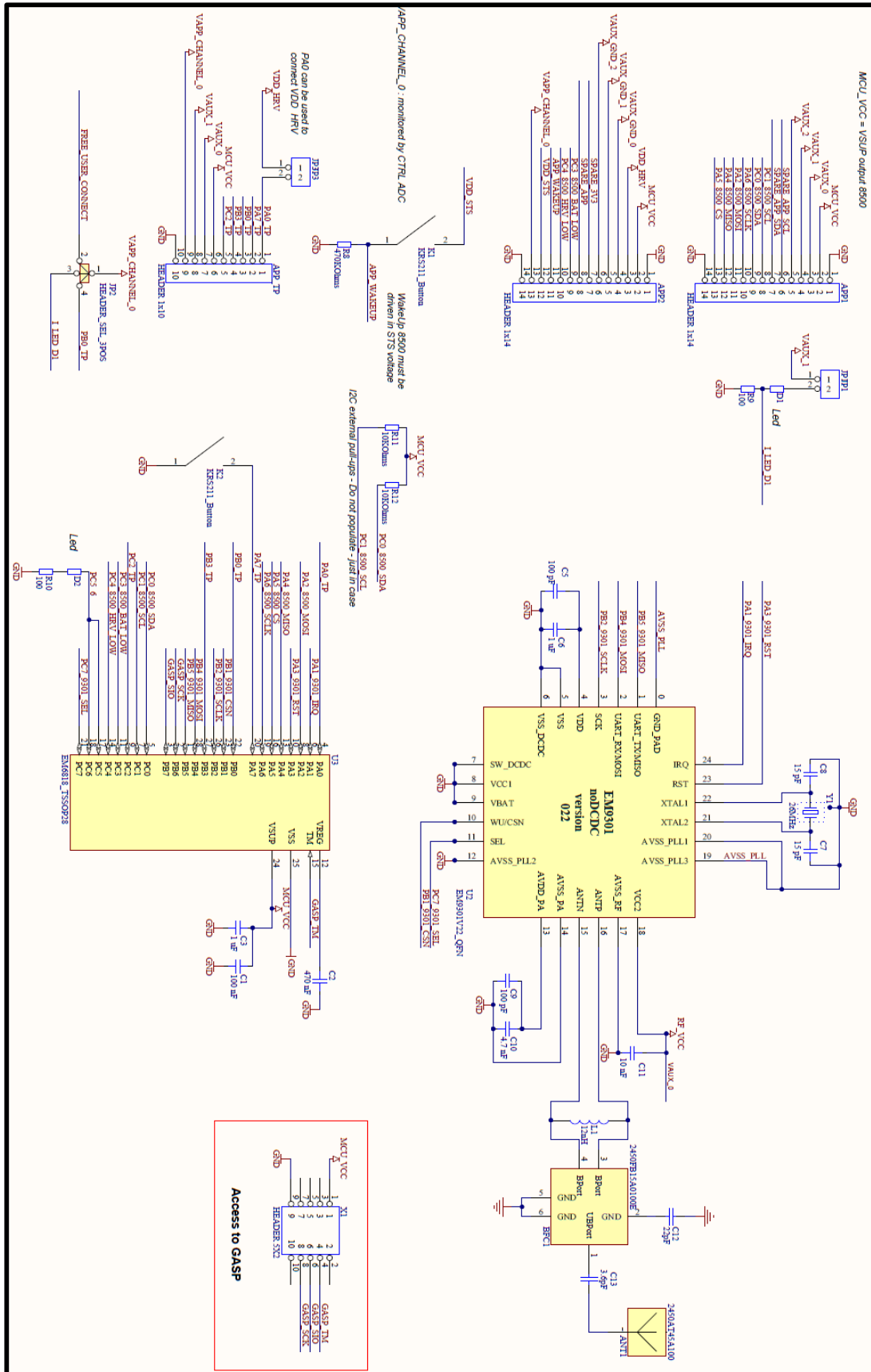

Figure 7-2: Application board schematic

7.3 BOM

	Part	Quantity
NT1	Chip antenna 2450AT45A100	1
APP2	HEADER 1x14	2
APP_TP	HEADER 1x10	1
BFC1	Balun 2450FB15A0100E	1
C1	100 nF	1
C2	470 nF	1
C3	1 uF	1
C5	100 pF	1
C6	1 uF	1
C7, C8	15 pF	2
C9	100 pF	1
C10	4.7 nF	1
C11	10 nF	1
C12	22pF	1
C13	3.6pF	1
JP1	JP1	1
JP2	HEADER Selection_3 Positions	1
JP3	Jumper JP3	1
K1, K2	Button KRS211	2
L1	12nH	1
R8	470KOhms	1
R9, R10	100Ohms	2
R11, R12	10KOhms	2
U2	EM9301	1
U3	EM6818	1
X1	HEADER 5X2	1
Y1	Quartz 26MHz	1
D1, D2	Led	2

Table 7-1 APP2 Pin-out description

7.4 INTERNAL MEASUREMENT: A/D ACQUISITION UNIT

One ADC single-ended channel is used for application board node voltage measurements. The node is shown in Figure 7-1: Application board description as "APP_ADC_CHANNEL" or Figure 7-2: Application board schematic as "VAPP_CHANNEL_0" or summarized below in Figure 7-3: Configuration for ADC application input.

The source of this ADC channel is selected through jumper JP2 as shown on the Figure 7-1: Application board description.

- I By connecting JP2 in position "PB0" the EM6819 pad PB0 (GPIO Port B bit 0) is connected to the A/D channel APP_ADC_CHANNEL ("VAPP_CHANNEL_0"). See Figure 7-3: Configuration for ADC application input configuration A.
- I By connecting JP2 in position "D1" the voltage across the resistor R9 serially connected to the LED D1, is connected to the A/D channel APP_ADC_CHANNEL ("VAPP_CHANNEL_0"). Additionally, to monitor the LED D1 current, the jumper JP1 must be placed to power D1 from the VAUX1 output of the EM8500. See Figure 7-3: Configuration for ADC application input configuration B.

TEST POINT	DOMAIN	SERIAL RESISTOR		DESCRIPTION
		NAME	VALUE	
JP1/JP3	Led D1	R9	100 ohm	Led serial resistor

Table 7-2 D1 monitoring

$$I(t)_{D1} = V(t)_{R9} / R9$$

- I By connecting JP2 to position "USER" the user input is connected to A/D channel APP_ADC_CHANNEL ("VAPP_CHANNEL_0"). The user signal can be applied on the connector APP_TP (pin 9). See Figure 7-3: Configuration for ADC application input configuration C.

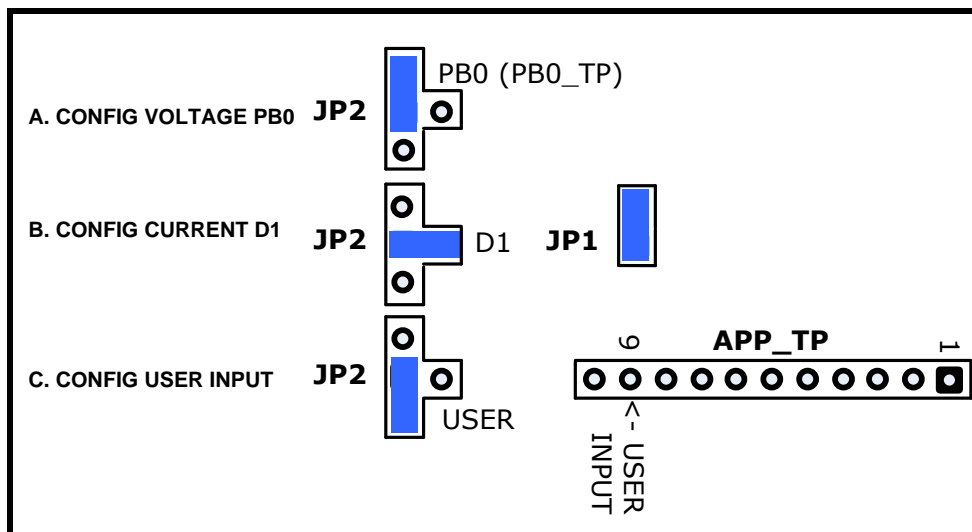

Figure 7-3: Configuration for ADC application input

8 DAUGHTER BOARD

8.1 OVERVIEW

The EMDVK85xx daughter board development kit is the board containing the EM85xx device.

The board is equipped with:

- | The power management controller EM85xx in MLF24 package
- | External components for EM85xx
- | Specific measurements nodes on HRV, LTS, STS, VSUP and VAUX to be measured by the A/D acquisition unit of the Base board
- | Shunt resistors to monitor the current profiles of the HRV, LTS and STS.
- | Switches to independently connect the HRV, LTS and STS.
- | Switches to enable some discharge path on HRV, LTS and STS
- | Relays to select the SPI or I²C coming from the Base board or the Application board.
- | Relays to connect the wake-up input from the Base board or the Application board.
- | Connections to the EM85xx flags (HRV_LOW BAT_LOW) to the Base board or the Application board.
- | Connection to HRV.
- | Super cap and rechargeable battery independently connectable to the LTS output
- | Connection to external LTS
- | Connection to external STS and spare footprint for additional STS capacitor
- | Jumper to connect or disconnect the LTS electronic
- | Jumper to connect or disconnect the STS electronic

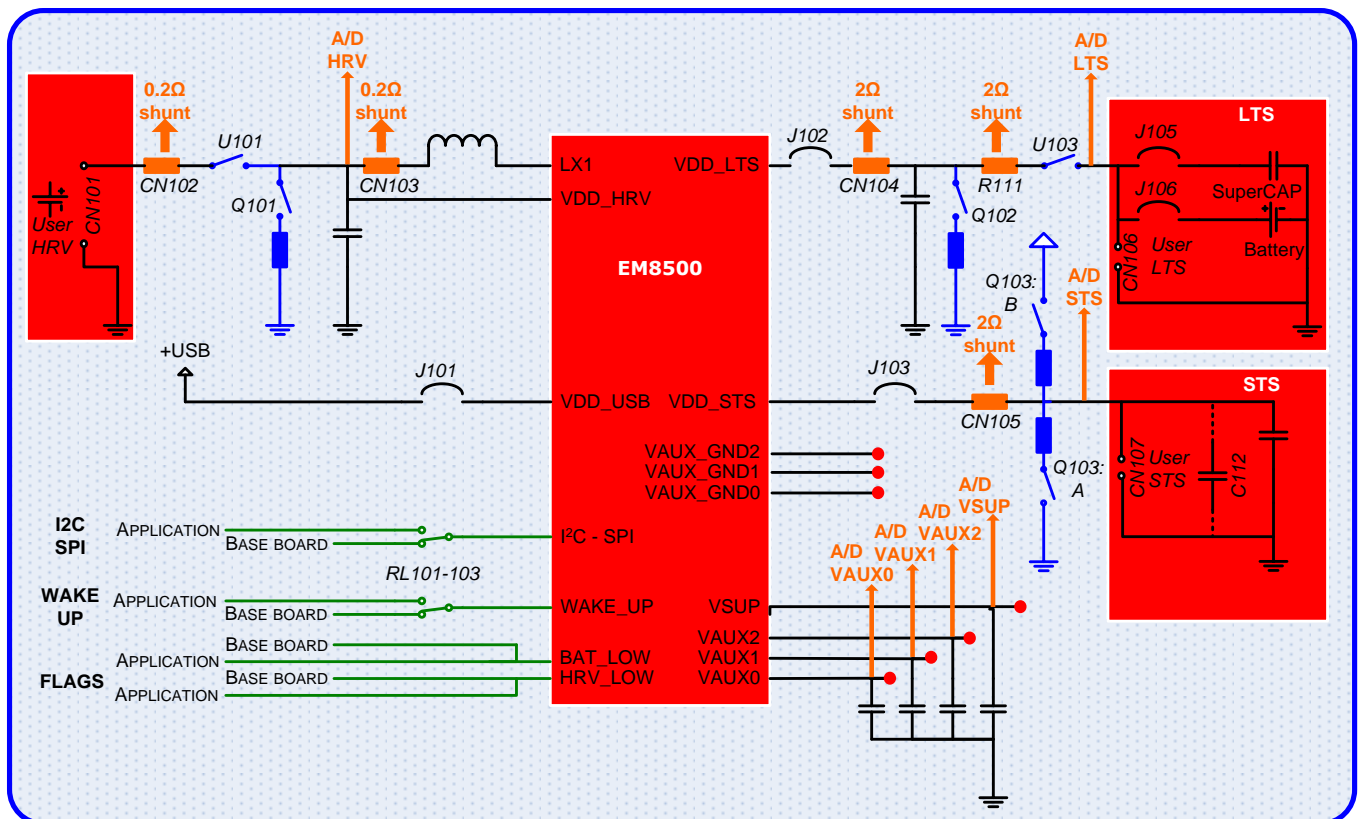

Figure 8-1: Daughter board simplified schematic variant EM8500

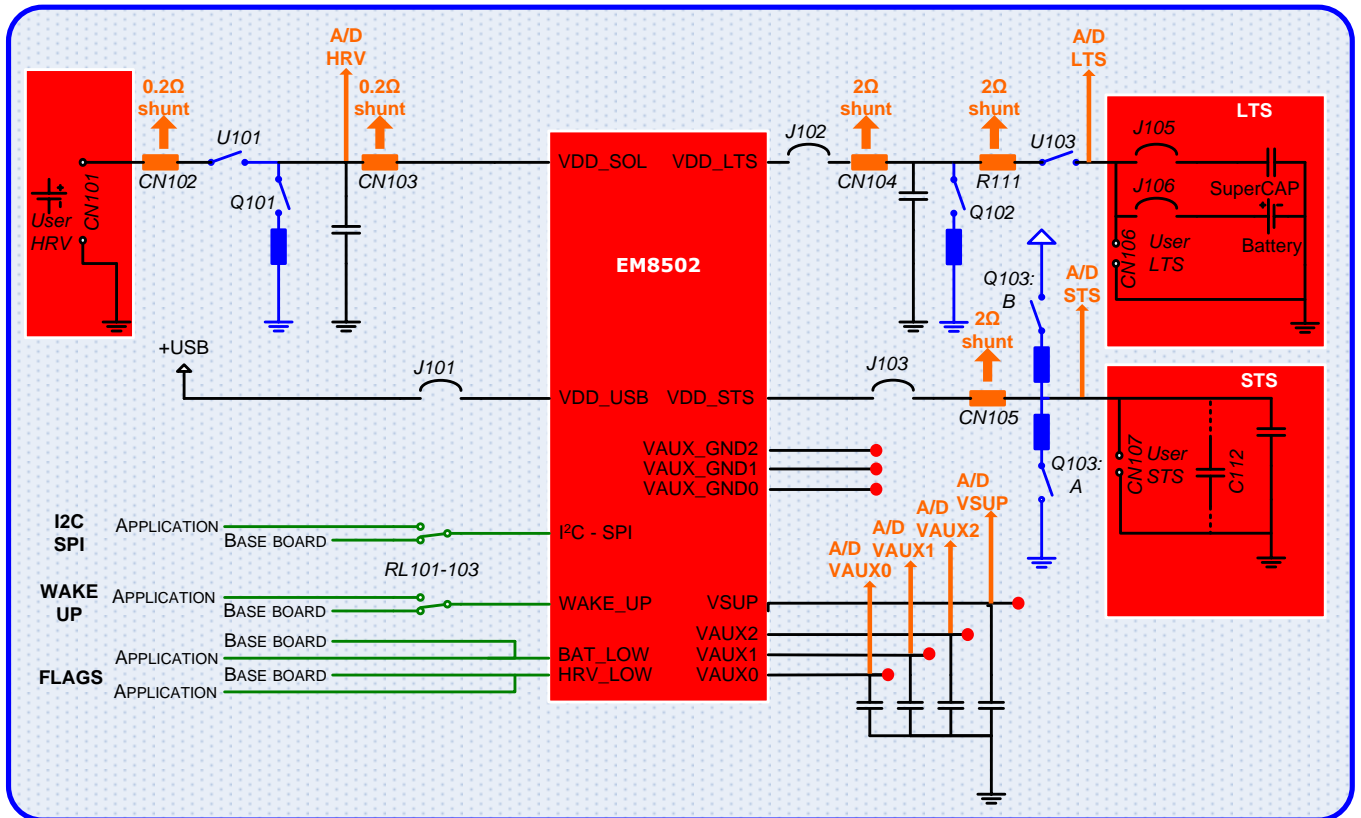

Figure 8-2: Daughter board simplified schematic variant EM8502

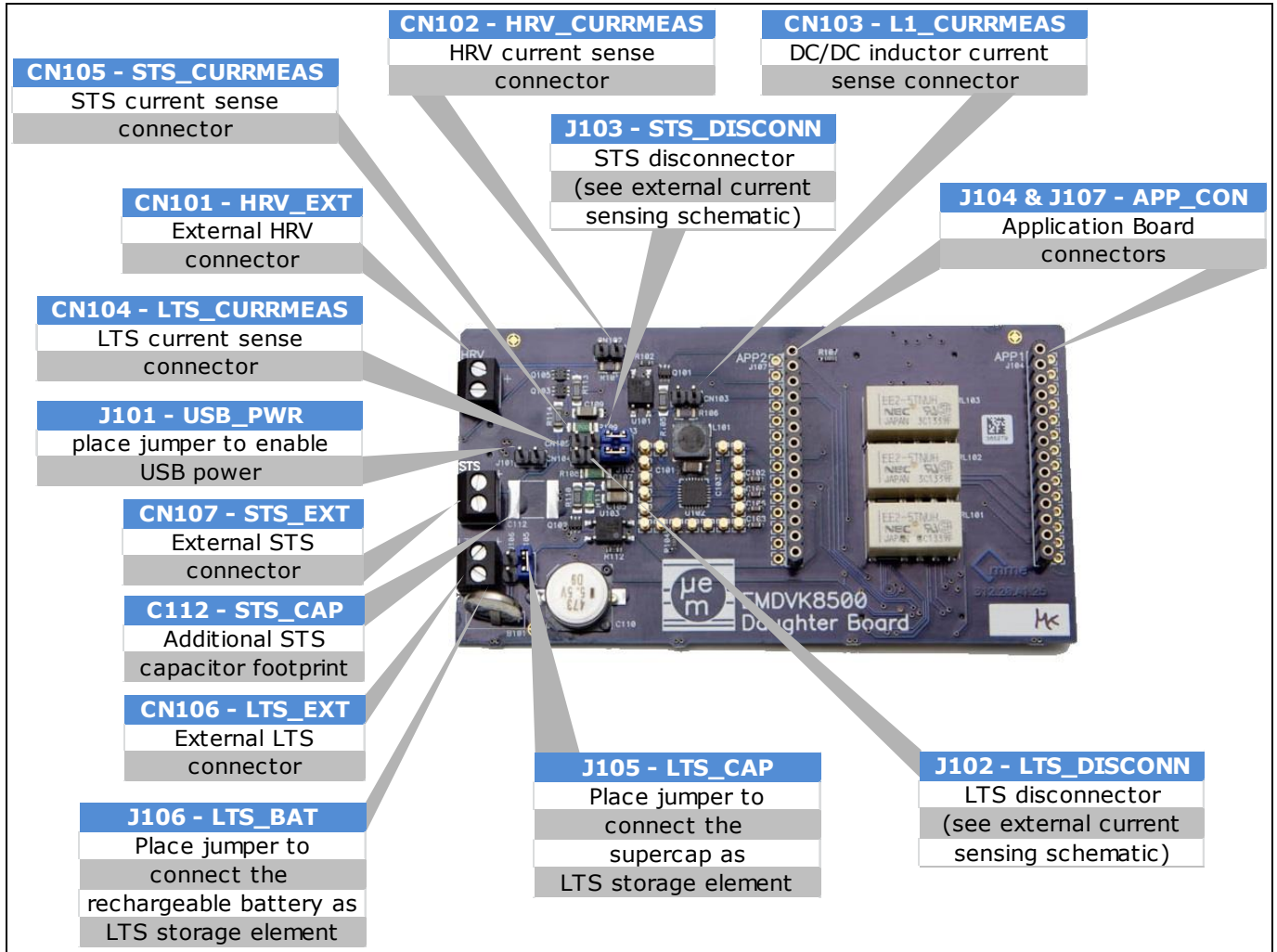

Figure 8-3: Daughter board description

8.2 INTERNAL MEASUREMENT: A/D ACQUISITION UNIT

Seven ADC single-ended channels are used for daughter board nodes voltage measurements. The nodes are shown on the

Figure 8-1: Daughter board simplified *schematic* as “A/D XXXX”. They concern the Harvester (A/D HRV), the Long-Term-Storage (A/D LTS), the Short-term-Storage (A/D STS) the VSUP (A/D VSUP) and the three VAUX (A/D VAUX0, VAUX1 and VAUX2).

8.3 EXTERNAL MEASUREMENT BY SHUNT RESISTORS

Beside the on-board voltage profiling and monitoring capabilities offered by the EMDVK85xx, some shunt resistors and connector test points are available in different places to allow voltage, current and power analysis with external lab equipment (oscilloscope or power analyser).

TEST POINT	DOMAIN	SHUNT RESISTOR		DESCRIPTION
		NAME	VALUE	
CN102	HRV	R101	0.2 ohm	HRV DC shunt
CN103	HRV	R106	0.2 ohm	HRV AC shunt
CN104	LTS	R108	2 ohm	LTS shunt
-	LTS	R111	2 ohm	LTS shunt – Reserved
CN105	STS	R109	2 ohm	STS shunt

Table 8-1 Shunt resistors description

8.4 CONNECTIONS FOR EXTERNAL HRV MEASUREMENTS

8.4.1 Oscilloscope measurements

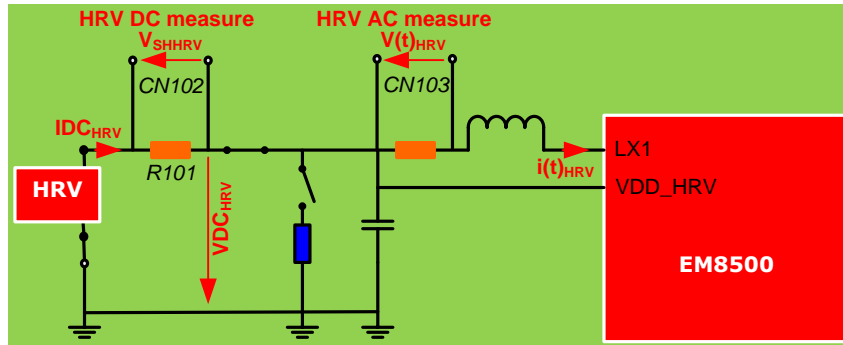

Figure 8-4: HRV measurements variant EM8500

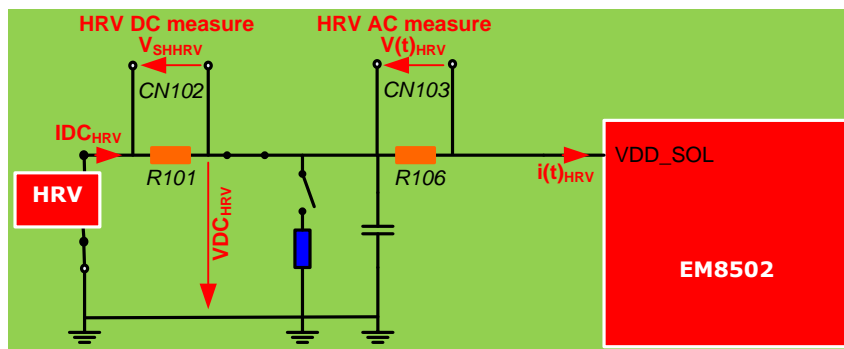

Figure 8-5: HRV measurements variant EM8502

In the DC domain the following measures can be performed:

(No jumper on CN102)

- | $IDC_{HRV} = V_{SHRV} / R101$
- | VDC_{HRV}

In the AC domain the following measures can be performed:

(No jumper on CN103)

- | $I(t)_{HRV} = V(t)_{HRV} / R106$

8.4.2 Power analyzer

Dedicated lab equipment (power analyser) can also be used to measure and analyse current flow, power, power efficiency etc ... Its connections depend on the lab equipment. Refer to the equipment manufacturer's user manual for proper connections.

8.5 CONNECTIONS FOR EXTERNAL LTS MEASUREMENTS

8.5.1 Oscilloscope measurements

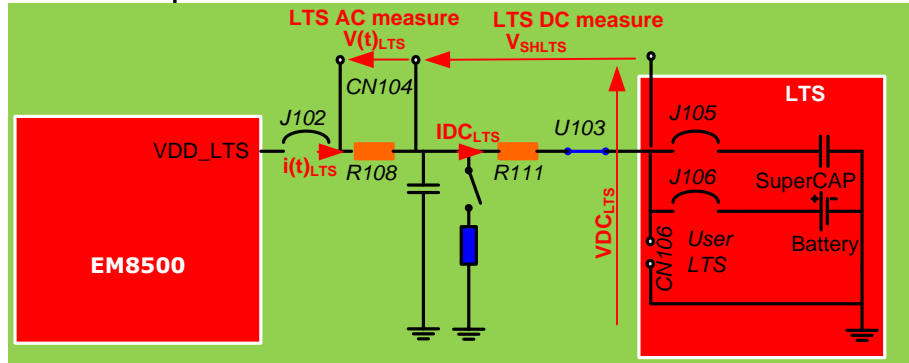

Figure 8-6: LTS measurements

In the DC domain the following measures can be performed:

- | $IDC_{LTS} = V_{SHLTS} / R111$
- | VDC_{LTS}

In the AC domain the following measures can be performed:

(No jumper on CN104)

- | $I(t)_{LTS} = V(t)_{LTS} / R108$

8.5.2 Power analyzer

Dedicated lab equipment (power analyser) can also be used to measure and analyse current flow, power, power efficiency etc. Its connections depends on the lab equipment. Refer to the equipment manufacturer's user manual for proper connections.

8.6 CONNECTIONS FOR EXTERNAL STS MEASUREMENTS

8.6.1 Oscilloscope measurements

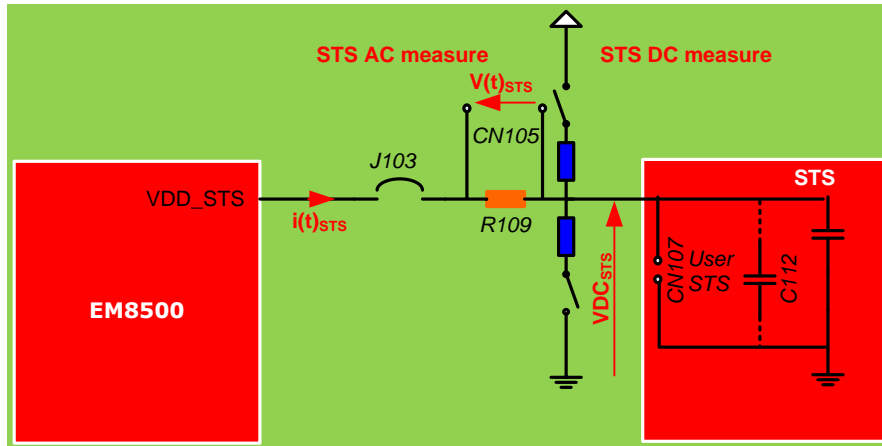

Figure 8-7: STS measurements

In the DC domain the following measures can be performed:

- | VDC_{STS}

In the AC domain the following measures can be performed:

(No jumper on CN105)

- | $I(t)_{STS} = V(t)_{STS} / R109$

8.6.2 Power analyzer

Dedicated lab equipment (power analyser) can also be used to measure and analyse current flow, power, power efficiency etc. Its connections depends on the lab equipment. Refer to the equipment manufacturer's user manual for proper connections.

9 BASE BOARD

9.1 OVERVIEW

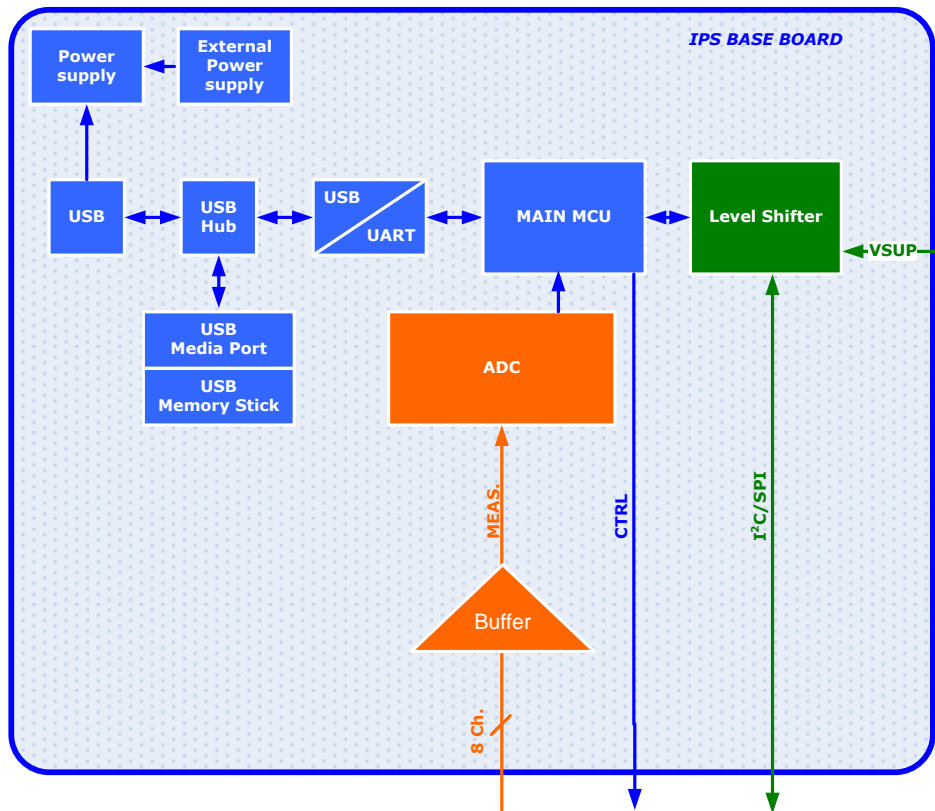

Figure 9-1: Base board simplified block diagram

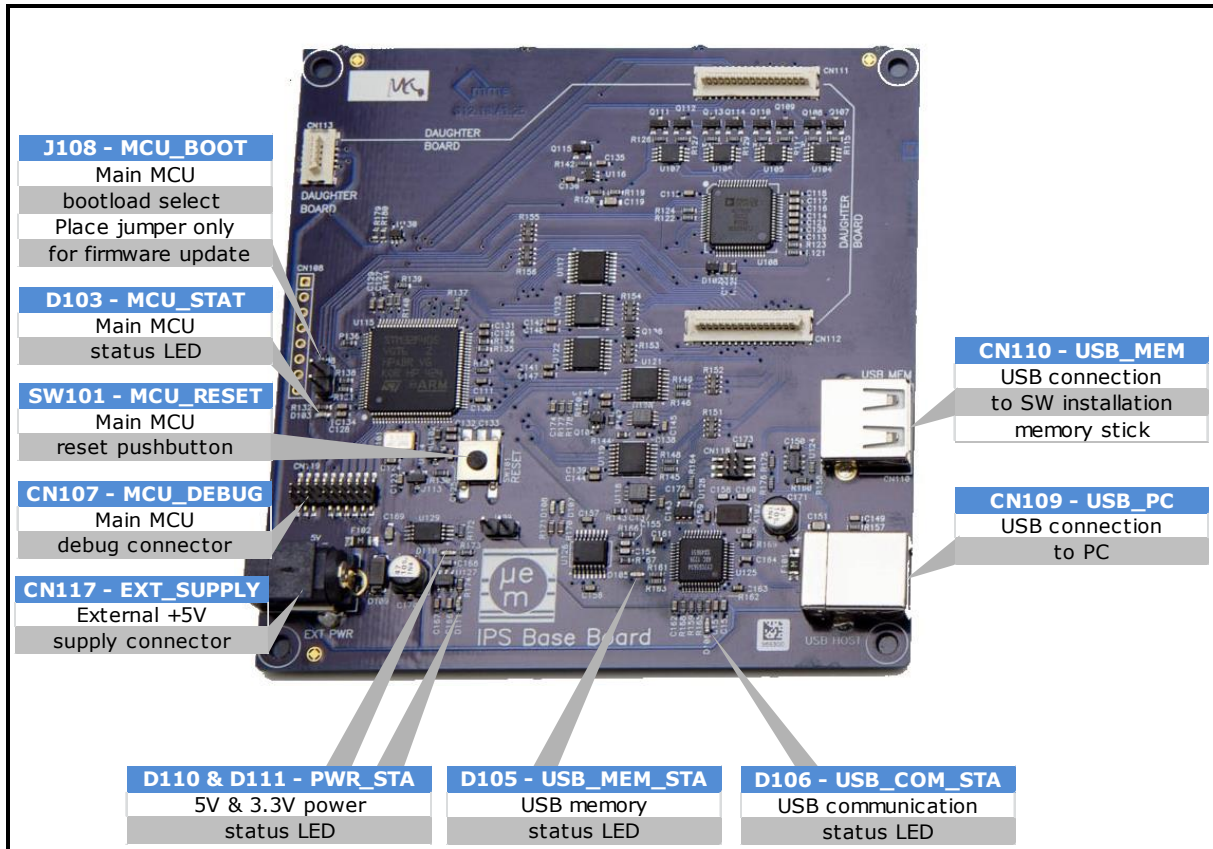

Figure 9-2: Base board description

10 EM8500 DEVELOPMENT EXPLORER USER INTERFACE

The EMDVK85xx is driven by the EM8500 Development Explorer user interface.

The user interface allows easy communication and configuration of the EM85xx device series through its EEPROM registers bank (write, read configuration). It supports loading and saving of EM85xx configurations, running measurements of the different EM85xx electrical nodes, monitoring and displaying of EM85xx electrical nodes.

The main window is shown below (Figure 10-1 EM8500 DevExplorer Main Window Description)

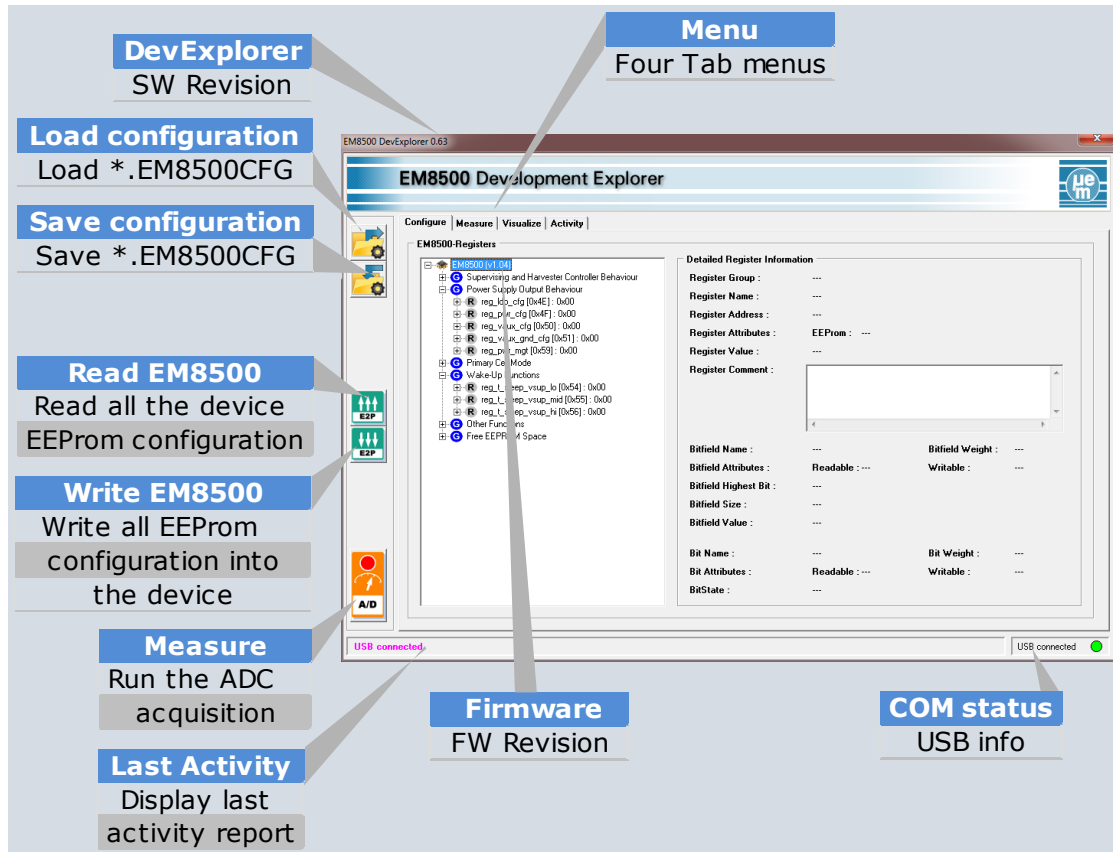

Figure 10-1 EM8500 DevExplorer Main Window Description

10.1 CONFIGURE MENU DESCRIPTION

This menu allows the user to control the EEPROM registers, to load and to save different configurations.

- | EM85xx Device configuration. This refers to the content of the EM8500 series device memory (EEProm registers).

- | The user interface (EM85xx Registers Configure window) is used to display or modify the content of the EEPROM register view. Each register group and register can be expanded. Each register or bit can be individually modified or read directly in this window.

- | The EM85xxCFG file configuration. This refers to the content of the *.em8500cfg file. An EM8500CFG file is the project and configuration file for the EM8500 DevExplorer. It contains different sections. The section referred as [Registers] is the memory configuration definition.

EM8500CFG file examples:

```
[Global]
Chip=EM8500 (V2.0 preliminary)
HWType=0x55
[Registers]
0x40=0x03
0x41=0x03
0x42=0x00
..... etc ...
[Options]
MainMode=ConfigurationMode
CommMode= FC
Switch_HR Venable=False
..... etc ...
```

Figure 10-2 EM8500 CFG file format for EM8500

```
[Global]
Chip=EM8502 (V2.0 preliminary)
HWType=0x65
[Registers]
0x40=0x03
0x41=0x03
0x42=0x00
..... etc ...
[Options]
MainMode=ConfigurationMode
CommMode= FC
Switch_HR Venable=False
..... etc ...
```

Figure 10-3 EM8500 CFG file format for EM8502

Four different buttons (Load, Save, Read and Write) are used to transfer and update the content from one type of configuration to another.

Figure 10-4 EM8500 DevExplorer configuration flow description) shows the different possible actions and data flow transfers.

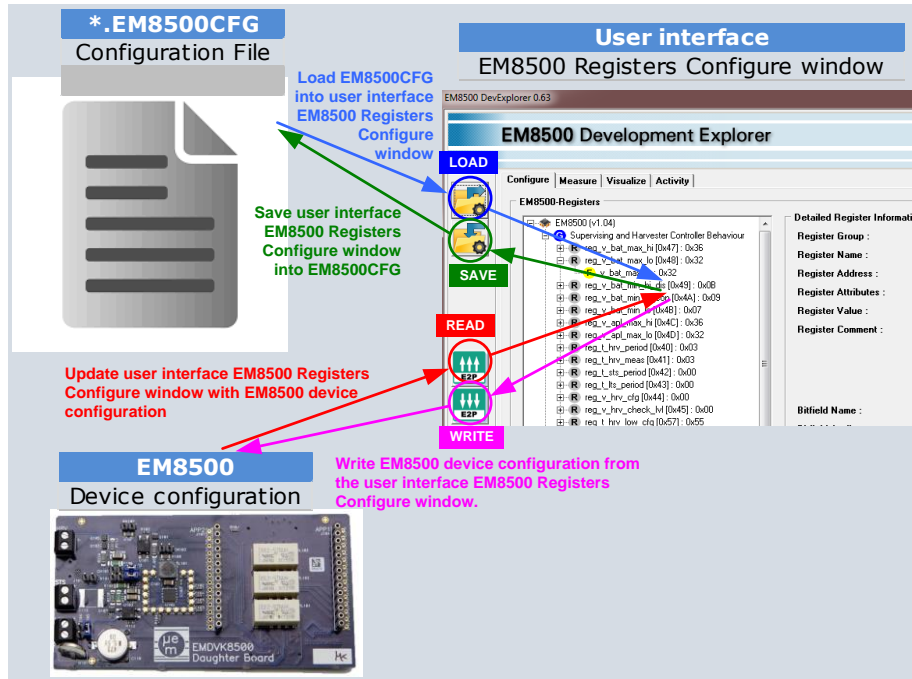

Figure 10-4 EM8500 DevExplorer configuration flow description

It is important to note that:

- | the “EM8500 Registers” view is not necessarily reflecting the physical content of the EM8500 EEPROM memory device and vice-versa.
- | the “EM8500 Registers” view is not necessarily reflecting the content of the EM8500CFG file and vice versa

10.2 MEASURE WINDOW DESCRIPTION

This menu allows the user to control the different switches/selectors and to start measurements.

Figure 10-5 EM8500 DevExplorer measure window description) describes these selections.

The “Configure mode” and the “Application mode” (described in the paragraph 5) can be selected through the selector called “Mode selector” in the Figure 10-5 EM8500 DevExplorer measure window description.

In Configure mode, the user is able to:

- | Use the Configure window to configure and access the EM85xx device
- | Control the HRV, STS and LTS switches (for hardware security reason some sequences are automatically managed or controlled by the tool)
- | Select (for configure mode) communication bus (I²C or SPI).
- | Run an INIT sequence to initialize the system
- | Start the ADC acquisition

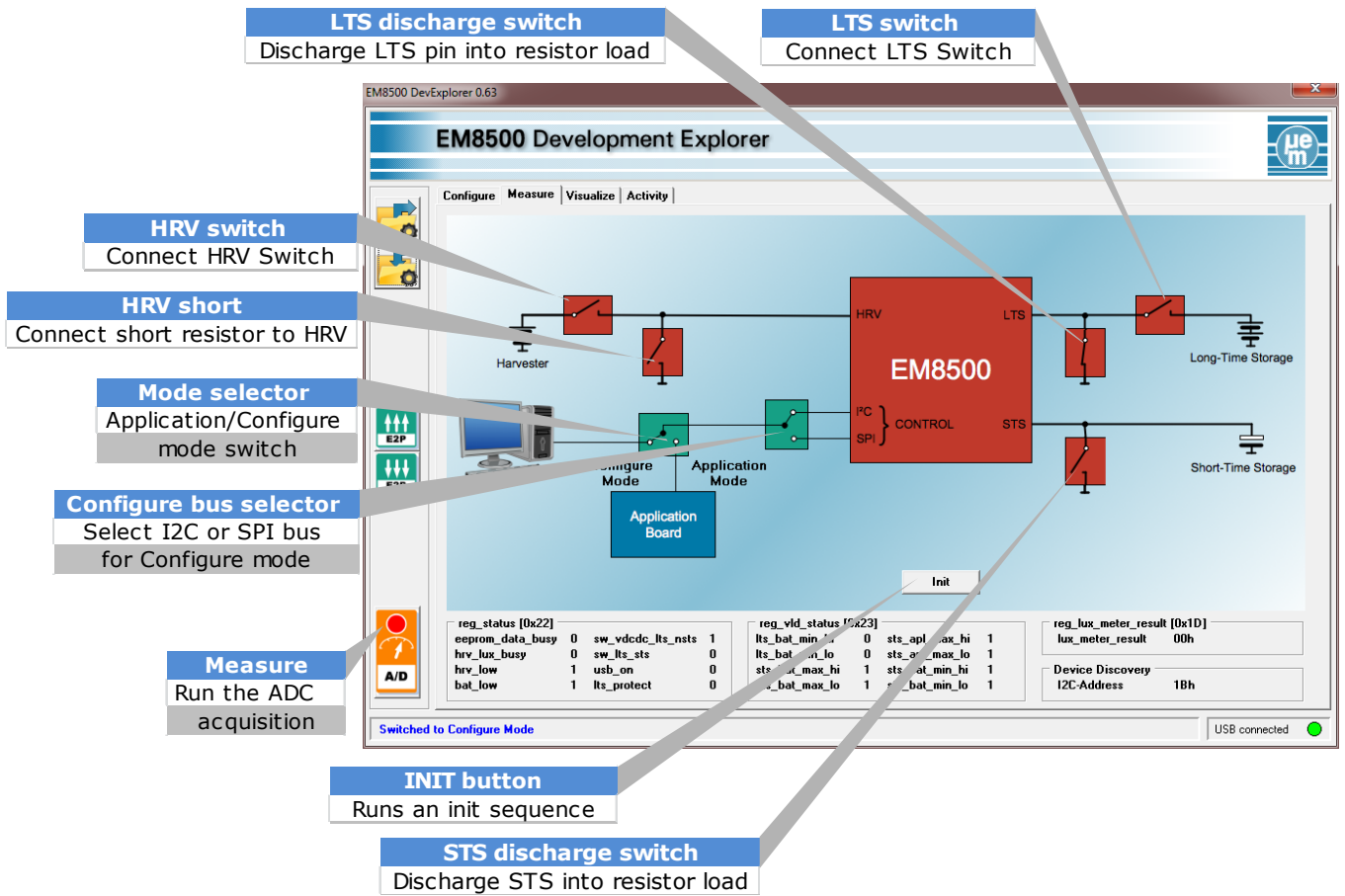

Figure 10-5 EM8500 DevExplorer measure window description

10.3 VISUALIZE WINDOW DESCRIPTION

This menu allows the user to add signals to be monitored in real-time. Selected signals are displayed in the two graphical windows shown below.

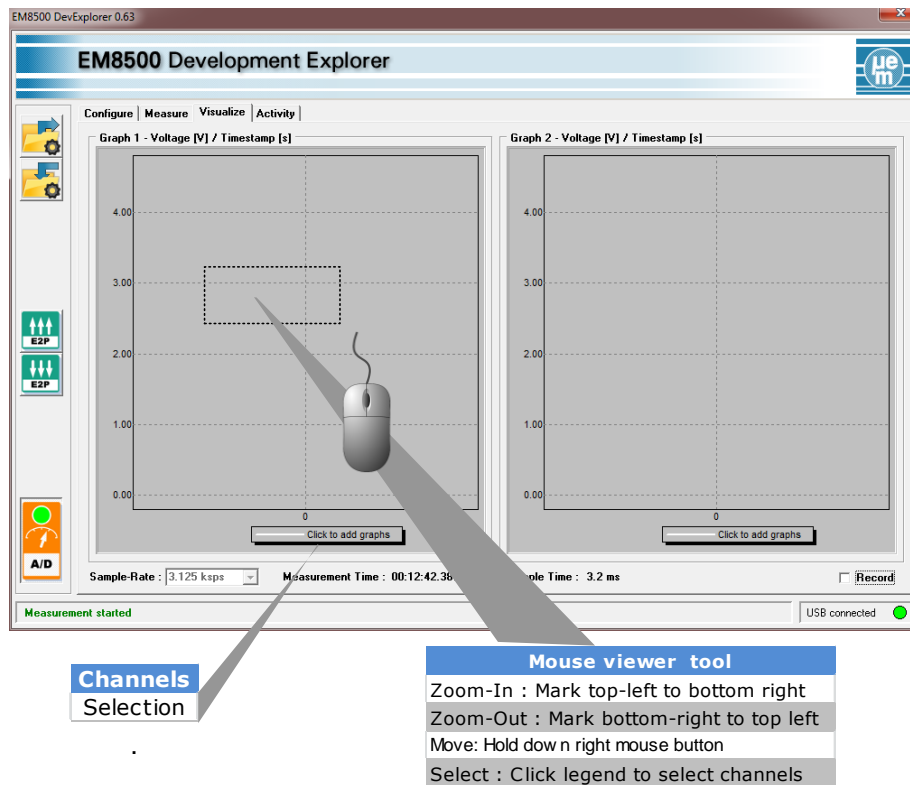
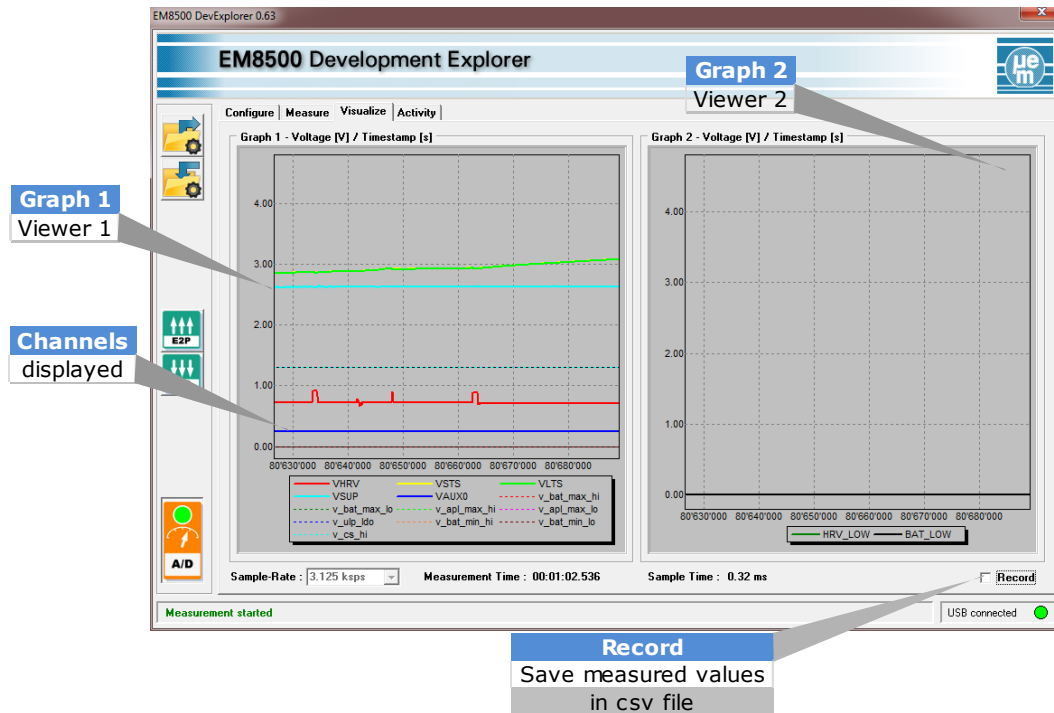

Figure 10-6 EM8500 DevExplorer visualize window description

The channel to be processed is available through the channel section menu. The measurement tool is able to monitor and display the measured values and threshold values. The selection menu can be access by a simple click on the “Click to add graph” button shown on the Figure 10-6 EM8500 DevExplorer visualize window description.

See below Figure 10-7 EM8500 DevExplorer visualize channel display selector

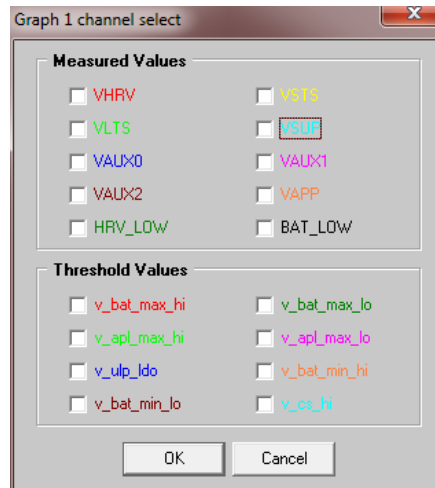

Figure 10-7 EM8500 DevExplorer visualize channel display selector

The user can also navigate within the waveforms. By using the mouse and the Mouse tool viewer the user is able to zoom in/out, move the displayed area or select different channels. The four available functions are:

- | **Zoom-In:** Mark top-left to bottom right
- | **Zoom-Out:** Mark bottom-right to top left
- | **Move:** Hold down right mouse button
- | **Select:** Click legend to select channels

Additionally all measurements can be logged. A recording function is available. By checking the box “Record”, monitored signals are saved in a CSV file.

10.4 MEASURE AND VISUALIZE WINDOWS - ACQUISITION UNIT INFORMATIONS

The graphs receive data from the analog-to-digital converters of the EMDVK85xx hardware.(Base board)
 The sampling rate is set by the drop-down menu below the graphs.

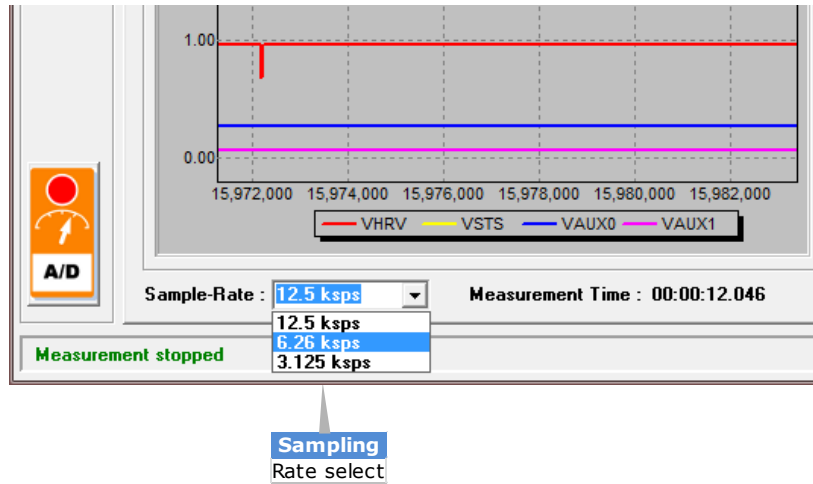

Figure 10-8 EM8500 DevExplorer visualize sampling rate selector

The time (x) axis (in seconds) is scaled dynamically as more and more samples are received.

The user may zoom into the time (x) or voltage (y) axis as required.

To maximize time resolution in the first seconds after starting a measurement, each sample received from the ADC is displayed, at up to 12.5 kSamples per second. After several seconds, a decimation of 10 starts (only 1 out of 10 samples is displayed). This decimation is required to avoid excessive amounts of data being collected. After a few minutes, decimation factor is increased from 10 to 100, then from 100 to 1000, and so on. The longer a measurement runs, the higher a decimation factor is applied. After stopping and restarting the measurement, decimation is reset to 1.

Even with decimation, it is possible to zoom into the time axis until individual samples are visible. It is, however, not possible to zoom into more detail than the decimation allows, because decimated values are discarded when reading from the ADC.

Data sample received from the ADC contain a time stamp. This time stamp is reset to zero when the EMDVK85xx is power-cycled. It increases continuously in time, even when measurements are stopped. The time stamp designates the exact moment in time when a sample is taken, regardless of decimation or stopping and restarting measurements.

Data from the graphs can be logged to CSV file.

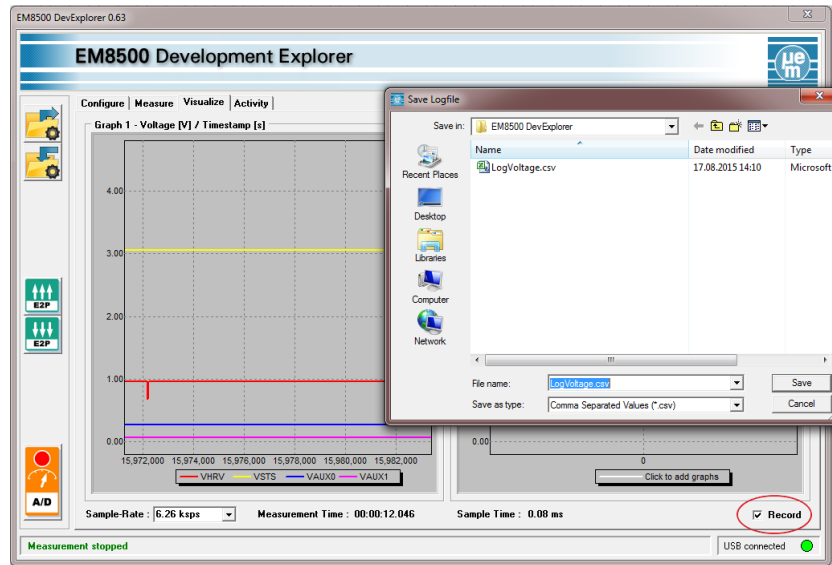

Figure 10-9 EM8500 DevExplorer visualize Record and CSV save function

Data in the log file is identical to the data graphed, including decimation and time stamp. The CSV file contains a header that identifies which column of data represents which voltage node. There is virtually no limit of how long data logging may run, as decimation avoids memory and hard disk overflows.

CSV file example:

Timestamp [ms], VHRV [V], VLTS [V], VSTS [V], VAUX0 [V], VAUX1 [V], VAUX2 [V], VSUP [V], VAPP [V], HRV_LOW [V], BAT_LOW [V],

```
16703461,0.9464,3.0440,3.0449,0.2779,0.0668,0.0484,2.6213,3.5980,0.0,0.0
16703461.16,0.9465,3.0440,3.0449,0.2779,0.0668,0.0484,2.6215,3.5942,0.0,0.0
16703461.32,0.9465,3.0441,3.0449,0.2779,0.0668,0.0484,2.6215,3.5928,0.0,0.0
16703461.48,0.9465,3.0441,3.0449,0.2780,0.0668,0.0484,2.6215,3.5938,0.0,0.0
16703461.64,0.9467,3.0441,3.0449,0.2779,0.0668,0.0484,2.6215,3.5936,0.0,0.0
16703461.8,0.9467,3.0440,3.0449,0.2779,0.0668,0.0484,2.6215,3.5939,0.0,0.0
```

11 TABLE OF CONTENTS

11.1 LIST OF FIGURES

Figure 1-1 EMDVK8500 deliverables	3
Figure 2-1 Configure boot mode (firmware update)	11
Figure 3-1 EMDVK8500 System Architecture	12
Figure 3-2 EMDVK8500 Configuration Mode	13
Figure 3-3 EMDVK8500 Application Mode	14
Figure 3-4 EMDVK8500 Stand-alone Mode with default application board	15
Figure 3-5 EMDVK8500 Stand-alone Mode with user application connections	16
Figure 4-1 EMDVK8500 Daughter board – application connections APP2 (J107) and APP1 (J104) - top view	17
Figure 5-1: Application board description	19
Figure 5-2: Application board schematic.....	21
Figure 5-3: Configuration for ADC application input	22
Figure 6-1: Daughter board simplified schematic variant EM8500	23
Figure 6-2: Daughter board simplified schematic variant EM8502	24
Figure 6-3: Daughter board description	25
Figure 6-4: HRV measurements variant EM8500.....	26
Figure 6-5: HRV measurements variant EM8502.....	26
Figure 6-6: LTS measurements.....	27
Figure 6-7: STS measurements	28
Figure 7-1: Base board simplified block diagram	29
Figure 7-2: Base board description	30
Figure 8-1 EM8500 DevExplorer Main Window Description	31
Figure 8-2 EM8500 CFG file format for EM8500	32
Figure 8-3 EM8500 CFG file format for EM8502	32
Figure 8-4 EM8500 DevExplorer configuration flow description	33
Figure 8-5 EM8500 DevExplorer measure window description	34
Figure 8-6 EM8500 DevExplorer visualize window description	35
Figure 8-7 EM8500 DevExplorer visualize channel display selector	36
Figure 8-8 EM8500 DevExplorer visualize sampling rate selector	37
Figure 8-9 EM8500 DevExplorer visualize Record and CSV save function	38

11.2 LIST OF TABLES

<i>Table 6-1 APP1 Pin-out description</i>	17
<i>Table 6-2 APP2 Pin-out description</i>	18
<i>Table 7-1 APP2 Pin-out description</i>	21
<i>Table 7-2 D1 monitoring</i>	22
<i>Table 8-1 Shunt resistors description</i>	25

EM Microelectronic-Marin SA (“EM”) makes no warranties for the use of EM products, other than those expressly contained in EM’s applicable General Terms of Sale, located at <http://www.emmicroelectronic.com>. EM assumes no responsibility for any errors which may have crept into this document, reserves the right to change devices or specifications detailed herein at any time without notice, and does not make any commitment to update the information contained herein.

No licenses to patents or other intellectual property rights of EM are granted in connection with the sale of EM products, neither expressly nor implicitly.

In respect of the intended use of EM products by customer, customer is solely responsible for observing existing patents and other intellectual property rights of third parties and for obtaining, as the case may be, the necessary licenses.

Important note: The use of EM products as components in medical devices and/or medical applications, including but not limited to, safety and life supporting systems, where malfunction of such EM products might result in damage to and/or injury or death of persons is expressly prohibited, as EM products are neither destined nor qualified for use as components in such medical devices and/or medical applications. The prohibited use of EM products in such medical devices and/or medical applications is exclusively at the risk of the customer