



EMEV8900 EVALUATION BOARD USER GUIDE

TABLE OF CONTENTS

1	INTRODUCTION	2
2	MAIN FEATURES	2
3	CONTENT DESCRIPTION	3
4	HARDWARE DESCRIPTION OVERVIEW	3
5	USER INTERFACE	4
6	TEST POINTS	5
6.1	SCHEMATIC	6
6.2	LAYOUT	7
6.3	BOM	8
7	TABLE OF CONTENTS	9
7.1	LIST OF FIGURES	9
7.2	LIST OF TABLES	10

1 INTRODUCTION

The EMEVB8900 board is targeted at rapid evaluation and prototyping of integrated energy harvesting solutions based on EM8900 device.

In particular, when combined with its companion chip EM8502, this board allows building a complete power management solution to harvest thermal energy, control energy storage elements and power a wide range of applications from wearables to industrial products.

The EMEVB8900 board comes in different configurations to cover different kind of application use cases. It allows flexibility with different set of combination, external harvester input, external DCDC boost converter, user connections and test points.

The EMEVB8900 is specifically suitable for being used with the EM8502 tools development (EMEVB8502 evaluation board, EMDVK8502 development kit) thanks to a specific and easy interconnection.

2 MAIN FEATURES

- | Flexible architecture for prototyping, test and customer application
- | Transformer, feedback capacitor, AC coupling capacitor and harvester capacitor
- | Ready to measure nodes for lab equipment (oscilloscope, power analyzer, ...)
- | Expansion header for prototyping and external connection (compliant with other EM power management and harvesting solutions) as shown below.

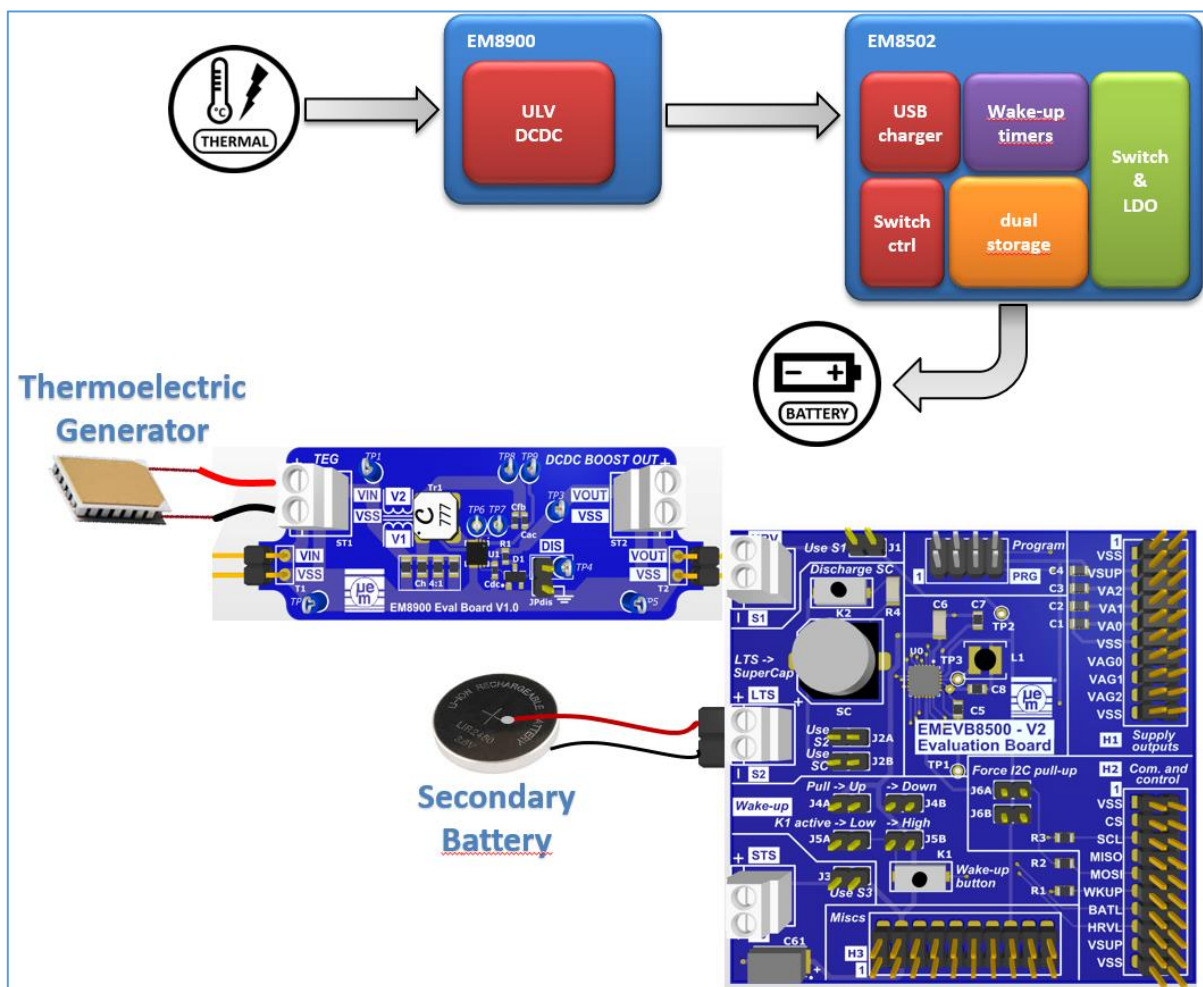

Figure 2-1 Example of tools development system - EMEVB8900 with EMEVB8502

3 CONTENT DESCRIPTION

The EMEVB8900 kit consist of the EM8900 Evaluation Board.

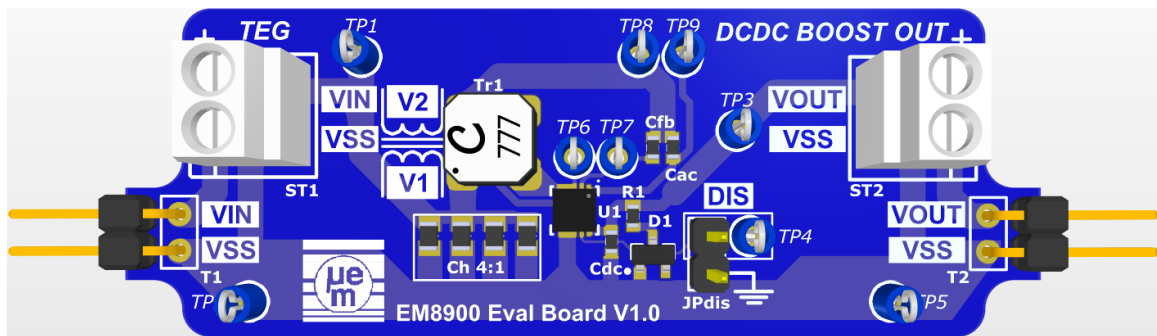

Figure 3-1 EMEVB8900

4 HARDWARE DESCRIPTION OVERVIEW

The EMEVB8900 exists in four different variants to support different use cases of the EM8900 series. The common architecture of the EMEVB8900 is based on the following block diagram.

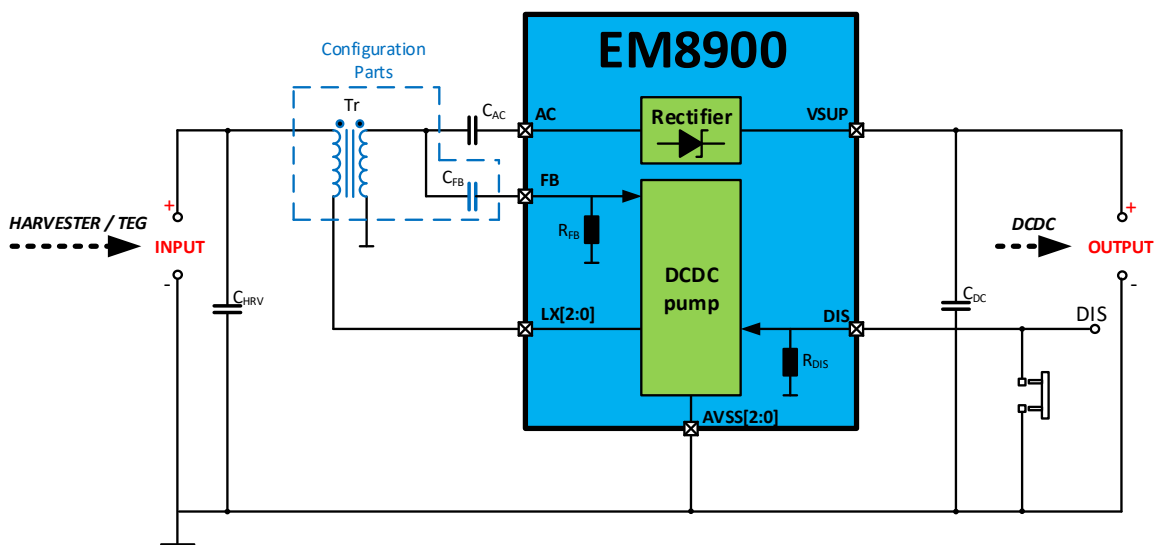

Figure 4-1 EMEVB8900 Architecture

The parts referenced as Tr (Coil) and C_{FB} (capacitor) are the elements that can be chosen according to the application requirements.

The EM8900 Evaluation board (EMEVB8900) connects its input to the harvester and its DCDC output to the source of the application (can be the EM8502).

The EM8900 Evaluation board contains an integrated ultra-low power DCDC converter (EM8900) and few external parts:

- | Transformer (**Tr**) with different turn ratio – typically from 1:20 to 1:100
- | Coupling capacitor from transformer to DCDC boost (**C_{FB}**) – different values typically from 22pF to 270pF
- | Coupling capacitor from transformer to rectifier (**C_{AC}**)
- | DCDC output capacitor (**C_{DC}**)
- | Harvester capacitor (**C_{HRV}**)

5 USER INTERFACE

The application connector T1, ST1, T2 and ST2 provide all the connections for the application.

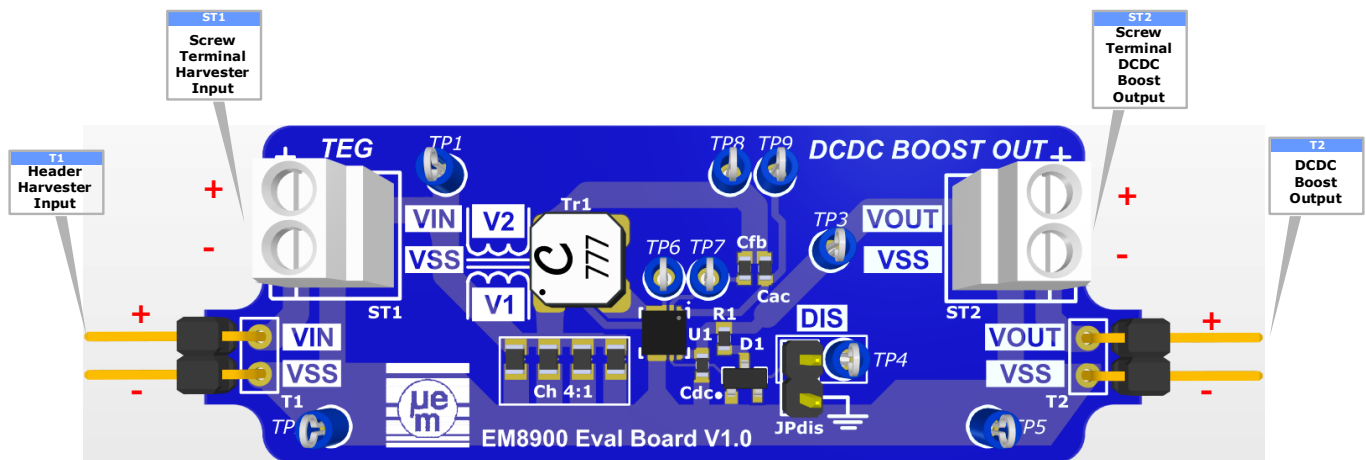

Figure 5-1 EMEVB8900 board – Application connections - top view

CONNECTION	PIN NAME	DIRECTION(*)	I/O TYPE	DESCRIPTION
ST1,T1	VIN	Input	Supply	Harvester input - Polarity +
ST1,T1	VSS	Input	-	Harvester input - System ground
ST2,T2	VOUT	Output	Supply	DCDC Boost output - Polarity +
ST2,T2	VSS	Output	-	DCDC Boost output - System ground
JP _{DIS}	DIS	Input	Digital	DCDC Boost output disable

Table 5-1 Board Pin-out description

(*): DIRECTION is defined from the EMEVB8900 point of view

The DIS pin is directly accessible on TP4 (test point plug).

By adding a jumper on JP_{DIS} the DIS pin shall be connected to the ground of the system. If no jumper is inserted the pin need to be forced externally (the internal weak pull down value of the EM8900 does not allow to let this pin floating).

If the Input pin DIS is connected to the ground, the DCDC is enabled.

If the Input pin DIS is connected to the logical level '1', the DCDC is disabled.

By default the output of the DCDC is protected against over voltage by a zener diode D1 (voltage clamped to 6.8V). This zener diode is connected through a 0 ohm resistor R1. By disconnecting the zener diode (e.g: removing the 0 ohm resistor) the system won't be protected against voltage surge.

The zener diode has been chosen in order to minimize its leakage current.

We strongly recommend users to keep this protection unless you make sure that the system is loaded and the DCDC output voltage shall be limited (e.g: by connecting the DCDC output to the EM8502).

Note: Connection to the TEG.

Due to the low voltage range (down to few mV) and the relatively high current (up to several tens of mA), the wiring to the TEG or equivalent source must be done in order to minimize losses in the corresponding path. Depending on the wiring (length, size and contact), the voltage drop might decrease significantly the efficiency of the system and introduce some unexpected overload. To minimize the voltage drop:

- the wiring must be as short as possible.
- the connection from the TEG to the TEG input of the of the EM8900 module should ensure a low resistive path. We recommend either using soldered wires or strong connection to ST1 or T1.

6 TEST POINTS

In addition, some test points (TP1 to TP9) are available on the board.

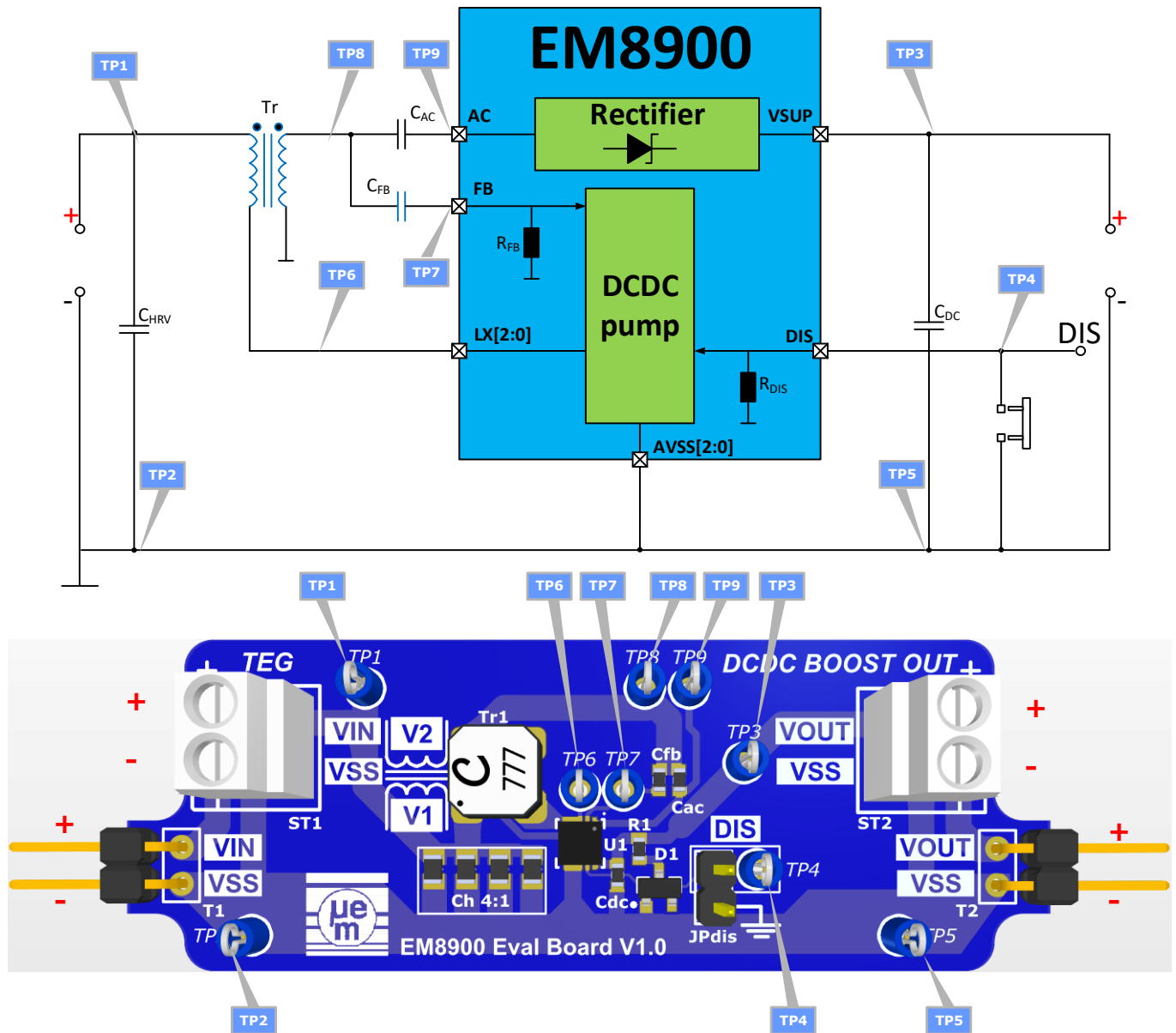

Figure 6-1 EMEVB8900 board – Test points position - Top view

By probing the tests points, you may cause some side effect. Due to the resistivity or the capacitive loading of the probes, the behaviour of the system might be strongly modified.

We do not recommend probing the test points TP7, TP6 and TP9 (unless you ensure to use the right active probes).

6.1 SCHEMATIC

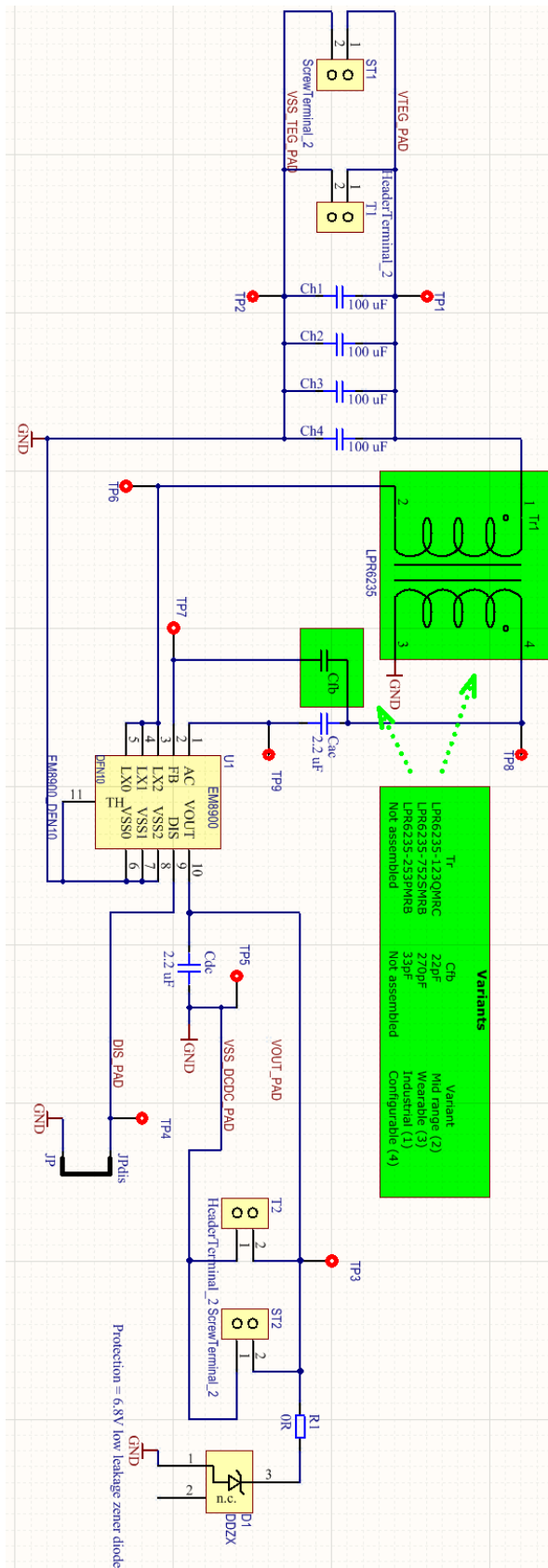

Figure 6-2 EMEVB8900 board – Schematic

6.2 LAYOUT

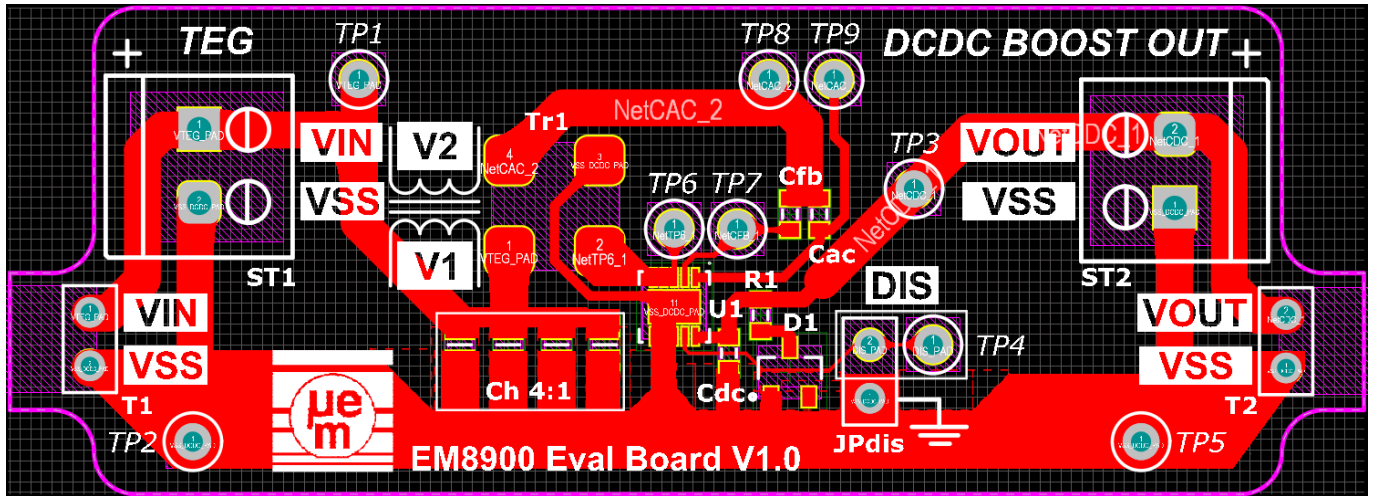

Figure 6-3 EMEVB8900 board – Layout

6.3 BOM

Designator	Part	Quantity
C _{AC} , C _{DC}	Capacitor 2.2uF	2
C _{H1} to C _{H4}	Capacitor 100uF	4
D1	Zener diode 6.8V	1
JP _{DIS}	Jumper	1
R1	Resistor 0 ohm	1
ST1,ST2	Screw terminal	2
T1,T2	Header	1
TP1 to TP9	Test pin plug	1
U1	EM8900	1
Cfb	Capacitor 22pf (variant mid-range) 270pf (variant wearable) 33pf (variant industrial) Not mounted (variant configurable)	1
Tr	Coil transformer 1:50 turn ration (variant mid-range - LPR6235-123QMRC) 1:100 turn ration (variant wearable - LPR6235-752SMRB) 1:20 turn ration (variant industrial - LPR6235-253PMRC) Not mounted (variant configurable)	1

Table 6-1 Bill of Material

7 TABLE OF CONTENTS

7.1 LIST OF FIGURES

Figure 2-1 Example of tools development system - EMEVB8900 with EMEVB8502	2
Figure 3-1 EMEVB8900.....	3
Figure 4-1 EMEVB8900 Architecture	3
Figure 5-1 EMEVB8900 board – Application connections - top view	4
Figure 6-1 EMEVB8900 board – Test points position - Top view.....	5
Figure 6-2 EMEVB8900 board – Schematic.....	6
Figure 6-3 EMEVB8900 board – Layout	7



7.2 LIST OF TABLES

Table 5-1 Board Pin-out description 4
Table 6-1 Bill of Material..... 8

EM Microelectronic-Marin SA (“EM”) makes no warranties for the use of EM products, other than those expressly contained in EM's applicable General Terms of Sale, located at <http://www.emmicroelectronic.com>. EM assumes no responsibility for any errors which may have crept into this document, reserves the right to change devices or specifications detailed herein at any time without notice, and does not make any commitment to update the information contained herein.

No licenses to patents or other intellectual property rights of EM are granted in connection with the sale of EM products, neither expressly nor implicitly.

In respect of the intended use of EM products by customer, customer is solely responsible for observing existing patents and other intellectual property rights of third parties and for obtaining, as the case may be, the necessary licenses.

Important note: The use of EM products as components in medical devices and/or medical applications, including but not limited to, safety and life supporting systems, where malfunction of such EM products might result in damage to and/or injury or death of persons is expressly prohibited, as EM products are neither destined nor qualified for use as components in such medical devices and/or medical applications. The prohibited use of EM products in such medical devices and/or medical applications is exclusively at the risk of the customer