



# Bluetooth® Low-Energy Proximity Beacon With Accelerometer



## FEATURES

- | Supports all popular beacon formats such as iBeacon™, Eddystone™, AltBeacon™, and compatible with Quuppa Intelligent Locating System™
- | Unique iBeacon ID and scannable QR-code come standard
- | Accelerometer can be used to activate beaconing on actions such as movement or gestures
- | Secure over-the-air updates possible with all major mobile platforms in the field
- | Multiple interleaved packet types with customizable parameters:
  - | Packet types, including custom packet types
  - | Device name, address, manufacturer name, model number, HW/SW revision
  - | UUID, Major/Minor ID, UID or URL
  - | Beacon interval, Transmitter power
  - | Accelerometer function and sensitivity
- | Firmware can be customized and loaded at production for large quantity orders
- | Over 4 year battery lifetime with 6 hours of activity per day
  - | Battery lifetime calculator available
- | Up to 200m range line-of-sight (LOS) at maximum output power
- | Push button with LED feedback (red and green)
- | Weatherproof Enclosure (IP-64 Rating)
- | Key-fob or custom accessories available
- | Available with an optional connector for
  - | Software development
  - | Adding sensors
  - | Alternate power source
- | Available as PCB module with CR2032 battery standard
  - | Allows support of other 20 and 24mm coin cell batteries and custom housing designs
- | Temperature range from -20C to +60C
- | Modular Bluetooth V5.0, FCC, IC, and CE certified, RoHS and REACH compliant
- | Made with Swatch Electronics Group technologies:
  - | EM Microelectronic EM9304 Bluetooth V5.0 SOC
  - | Renata CR2032 coin-cell battery
  - | Micro Crystal 32.768kHz crystal

## DESCRIPTION

The EMBC22 is a high-performance, customizable Bluetooth V5.0 low energy proximity beacon with an accelerometer for tracking objects that move. Similar to the EMBC02, the EMBC22 comes in simple, easy to use coin-shape housing, and is now powered by the EM9304, the world's lowest power Bluetooth IC.

New features include:

- Longer life from a CR2032 battery
- Longer range (up to 200m LOS)
- Over-the-air configurability
- Multiple interleaved packet types
- Modular RF certification
- Optional connector for sensors or power source

The EMBC22 is compatible with major beacon formats including iBeacon™, Eddystone™, AltBeacon™ and compatible with Quuppa Intelligent Locating System™. The beacon is fully customizable over the air or in manufacturing. For example, the following parameters can be easily modified:

- Packet types, including custom packet type
- Device name, address, manufacturer name, model number, HW/SW revision
- UUID, Major/Minor ID, UID or URL
- Beacon interval, Transmitter power
- Accelerometer function and sensitivity

The EMBC22 can be shipped pre-programmed with custom firmware or custom parameters and can be securely updated in the field with over-the-air programming from a mobile device (all major iOS® and Android™ devices supported).

The EMBC22 accelerometer can be used to implement efficient and low-energy algorithms for various applications. The accelerometer can be used to activate beaconing on movement, or gestures, for example. When not active, the beacon consumes minimal energy.

The EMBC22 can be stored in Warehouse Mode without significantly degrading the battery lifetime. When active for 6 hours per day and configured for 0dBm output power and 1 second advertising intervals, the battery lifetime is more than 4 years.

The EMBC22 can be delivered in any quantity with guaranteed unique ID. A 2D unique serial number is printed on the beacon housing for optical scanning.

The EMBC22 is also available in PCB module format without housing. The module comes with the switch and battery holder. The beacon comes standard with a Renata CR2032/ 225mAh battery. Other Renata Lithium primary batteries such as CR2016/90mAh, CR2450/540mAh and CR2477/950mAh can be accommodated.

The EMBC22 comes in a waterproof housing, and operates over a -20C to +60C temperature range. The EMBC22 is modular Bluetooth V5.0, FCC, IC, and CE certified, RoHS and REACH compliant.



TABLE OF CONTENTS

- 1. GENERAL DESCRIPTION .....3
- 2. ENVIRONMENTAL AND STORAGE CONDITIONS.....4
- 3. PRODUCT OUTLINE DIMENSIONS .....4
  - 3.1. FINISHED PRODUCT .....4
  - 3.2. PCB .....4
- 4. MECHANICAL .....5
  - 4.1. PUSH BUTTON.....5
  - 4.2. LED.....5
- 5. ELECTRICAL .....5
  - 5.1. HANDLING PROCEDURES AND ABSOLUTE MAXIMUM RATINGS .....5
  - 5.2. GENERAL OPERATING CONDITIONS .....5
  - 5.3. ELECTRICAL CHARACTERISTICS .....6
  - 5.4. REGULATORY .....6
    - 5.4.1. Regulatory Information CE .....6
    - 5.4.2. Regulatory Information USA .....6
    - 5.4.3. Regulatory Information Canada .....7
- 6. FIRMWARE .....9
  - 6.1.1. State Machine Configuration Options .....9
  - 6.1.2. Hardware Features .....9
  - 6.1.3. Operating Modes .....10
  - 6.1.4. Mode Transitions .....13
  - 6.1.5. Accelerometer Configuration .....15
  - 6.2. ADVERTISEMENTS.....16
    - 6.2.1. Device Address.....16
    - 6.2.2. Advertising Channels.....16
    - 6.2.3. RSSI Table.....16
    - 6.2.4. Connectable Advertisement.....17
    - 6.2.5. Non Connectable Advertisements .....17
  - 6.3. SUPPORTED BLE SERVICES .....17
    - 6.3.1. Firmware Over The Air (FOTA) Service .....18
    - 6.3.2. Beacon Information Service.....18
    - 6.3.3. Device Information Service.....19
  - 6.4. QUUPPA PROPRIETARY SYSTEM COMPATIBILITY .....19
- 7. UNIT LABEL .....19
  - 7.1. SERIAL NUMBER.....20
- 8. PACKING AND LABELING .....20
  - 8.1. FINISHED PRODUCT .....20
    - 8.1.1. Inner Packing .....20
    - 8.1.2. External Packing.....20
- 9. ACCESSORIES .....20
- 10. ENVIRONMENTAL SAFETY .....20
- 11. ORDERING INFORMATION.....21
- 12. CONTACT INFORMATION.....21
- 13. REFERENCE DOCUMENTS .....21



## 1. GENERAL DESCRIPTION

The EMBC22 is a 2.4 GHz RF electronic beacon with proximity capability, compatible with most common beacon standards with a low cost design for mass production, and includes a low-power accelerometer for activation features.

### Over-the-air configurable:

- **Up to 10 advertisements running parallel and uniquely defined**
  - Multiple Industry Standard Packet Types
    - iBeacon™
    - altBeacon™
    - Eddystone™ UID, TLM, and URL
    - User defined
  - Wide range advertisement interval
    - From 30ms to 18hrs
  - 17 Output Power Steps
    - From +6dBm to -34dBm
  - Activity Gated Advertising Options
    - Continuous Advertising
    - Advertising On Activity
    - Advertising When Not Active
- **Simple state machine**
  - User defined events to enter Configuration Mode
    - Options for: Short button press, long button press or accelerometer flip
  - User defined events to toggle between Warehouse and Beaconsing Mode
    - Options for: Short button press, long button press or accelerometer flip
  - User configurable timeouts from the Configuration and Active Modes
    - From 100ms to 1.8hrs
  - User defined events to activate Activity Mode
    - Motion, tap, double tap, freefall, flip or short button press
  - Lockable
- **Flexible accelerometer settings**
  - Control of sensitivity, sampling rates, duration, etc. settings

### Long Range:

- 100m LOS at 0dBm
- 200m LOS at max output power

### Long Battery Life:

- Replaceable CR2032 Li 3V battery
- Up to 10 years storage life

### Normal Operating Conditions:

- -20 to +60 C
- Weather proof (IP-64 rating)

### Small and Lightweight:

- 30mm diameter x 10mm disk
- 7 grams

### Certifications:

- Environmental: RoHS, REACH, Halogen Free
- RF: FCC, IC, CE

### Compatible With:

- Bluetooth Smart Ready Devices
- Most Common Beacon Standards

### EMBC Configuration Tool

- A free smart phone and tablet application for:
  - iOS
  - Android

### Included Hardware:

- A white plastic enclosure
- A push button for mode changes
- A green and red LED for user feedback
- A permanent label with a unique serial number and QR Code

### Multiple Delivery Formats:

- Finished product
- Custom Firmware
- Custom Housing
- PCB Only

### Optional Mounting Accessories:

- Key-fob
- Other options possible (wall-mount, wrist-band are available upon demand)

### Multiple Battery Sizes:

- Standard in EMBC22 housing is CR2032/225mAh battery
- CR2016/90mAh, CR2450/540mAh, CR2477/950mAh (housing available upon demand)

### Fully Customizable:

- Development kit available
- Adjustable parameters
- Modifiable firmware

## 2. ENVIRONMENTAL AND STORAGE CONDITIONS

The operating and storage conditions are listed in Table 1.

Table 1: Environmental and storage conditions	
Module operating temperature and humidity range	-20°C to 60°C and 0 to 90% RH
Weatherproof	Module can be used in outdoor conditions. It is rated IP64 according to CEI 60529.
Module storage temperature and humidity range	Modules must be stored in original EM packing at Temp=25°C±5°C / RH 30-45%.

## 3. PRODUCT OUTLINE DIMENSIONS

### 3.1. FINISHED PRODUCT

The finished product outline dimensions are shown in Figure 1 for the CR2032 version only. Dimensions for housings for other battery sizes available upon request.

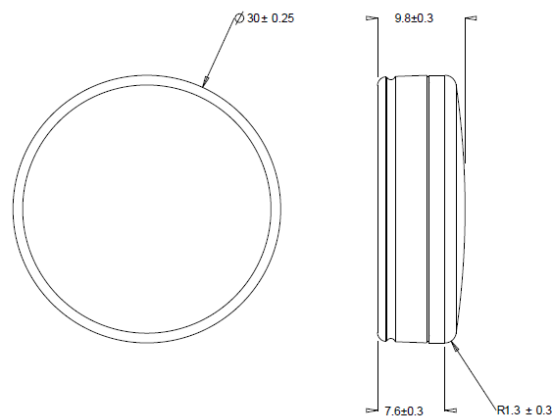

**Figure 1: EMBC22 finished product outline dimensions**

### 3.2. PCB

The EMBC22 accelerometer beacon module PCB is shown in Figure 2 with a 26mm diameter. An optional SlimStack™ connector (Molex PN 5037761610) can be used for software development (JTAG access), for connection to a daughter board with sensors for example, or to connect to a different power source such as a battery pack. The standard version comes with a CR2032 replaceable battery and battery holder. Battery sizes such as CR2016, CR2450, or CR2477 batteries can also be accommodated.

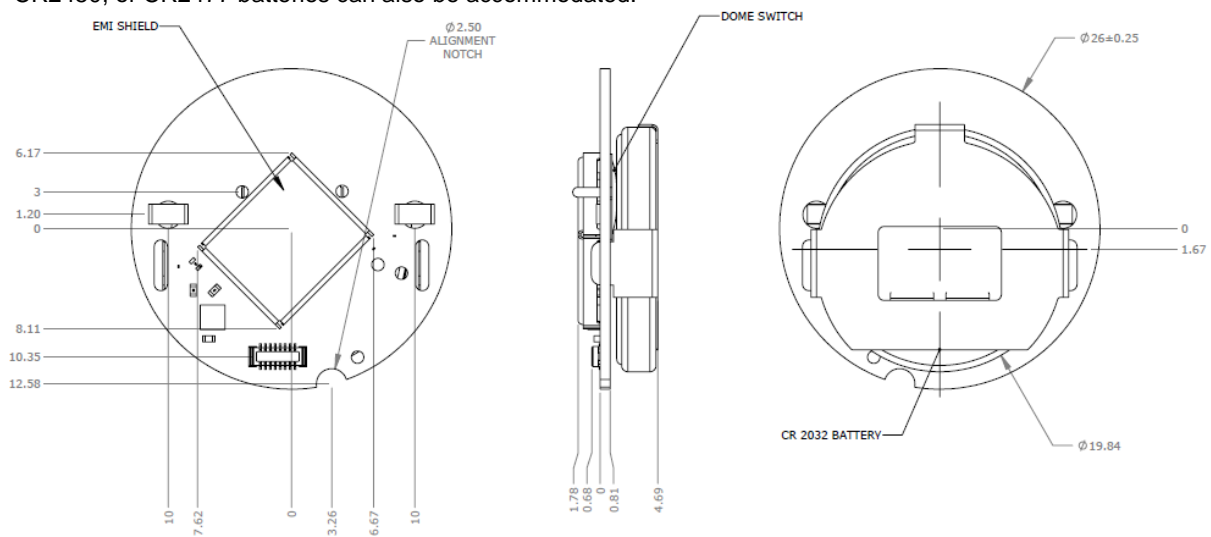

**Figure 2: Accelerometer beacon module PCB with connector (nominal dimension in mm)**

## 4. MECHANICAL

### 4.1. PUSH BUTTON

The push button is activated with a firm press. It is designed so that it cannot be activated accidentally.

### 4.2. LED

The green and red LEDs are visible through the plastic enclosure under indoor lighting conditions. LEDs are used to indicate the operating mode of the beacon.

## 5. ELECTRICAL

Typical values are stated at room temperature ( $T=25^{\circ}\text{C}$ ) with a supply voltage of  $V_{CC}=3.0\text{V}$ .

### 5.1. HANDLING PROCEDURES AND ABSOLUTE MAXIMUM RATINGS

The finished product is compliant with EN 61000-4-2 (Electrostatic Discharge) level 2: 4kV contact discharge and 4kV air discharge. This PCB module has built-in protection against high static voltages or electric fields; however, anti-static precautions must be taken when handling the PCB module, for example, when replacing the battery.

Unless otherwise specified, proper operation can only occur when all terminal voltages are kept within the specified voltage range. The absolute maximum ratings of are listed in Table 2.

Parameter	Min	Max	Unit
Supply Voltage $V_{CC} - V_{SS}$	-0.3	3.8	V

Stresses above these listed maximum ratings may cause permanent damage to the device. Exposure beyond specified operating conditions may affect device reliability or cause malfunction

**CAUTION. RISK OF EXPLOSION IF BATTERY IS REPLACED BY AN INCORRECT TYPE. DISPOSE OF USED BATTERIES ACCORDING TO THE INSTRUCTIONS.**

### 5.2. GENERAL OPERATING CONDITIONS

The general operating conditions are listed in Table 3.

Parameter	Min	Typ	Max	Unit
Supply Voltage ( $V_{CC}$ )	2.0	3.0	3.6	V
Temperature Range	-20	25	+60	$^{\circ}\text{C}$

### 5.3. ELECTRICAL CHARACTERISTICS

The electrical characteristics are given in Table 4 for a typical use case. A battery lifetime calculator is available to estimate battery the battery lifetime with alternate configurations.

Unless otherwise specified: VCC=3.0V, T=25°C.

	<b>Operating Mode</b>	<b>Specification</b>	<b>Min</b>	<b>Typ</b>	<b>Max</b>	<b>Unit</b>
<b>Use Case Operating Parameters</b>	Warehouse Mode	Storage Time		1		years
		Average Current		1.5		µA
	Beaconing Mode	Beacon Interval In Active Mode		1000		msec
		Output Power In Active Mode		0		dBm
		Average Current In Active Mode		15		µA
		Average Current in Inactive Mode		2.5		µA
		Line-of-Sight(LOS) Range		100		m
<b>Use Case Battery Life Based on Activity Level</b>	Example 1: 10% Activity	Percentage of Life in Active Mode		10		%
		Percentage of Life in Inactive Mode		90		%
		Lifetime Average Current		3.8		µA
		Battery Lifetime (CR2032)		73		months
	Example 2: 50% Activity	Percentage of Life in Active Mode		50		%
		Percentage of Life in Inactive Mode		50		%
		Lifetime Average Current		8.8		µA
		Battery Lifetime (CR2032)		31		months
	Example 3: 90% Activity	Percentage of Life in Active Mode		90		%
		Percentage of Life in Inactive Mode		10		%
		Lifetime Average Current		13.8		µA
		Battery Lifetime (CR2032)		19		months

Note 1: Battery Lifetime is calculated based on the average current using a Renata CR2032 battery with 225mAh of battery life under typical conditions.

Note 2: Beacon interval is the Bluetooth advertising interval (advInterval) as defined in the Bluetooth Specification V5.0, Volume 6, Part B, Section 4.4.2.2.

Note 3: Range is measured outdoors, line-of-sight, with an iPhone™. 4S

### 5.4. REGULATORY

EMBC22 is modular certified and complies with the following regulatory requirements:

#### 5.4.1. Regulatory Information CE

EM Microelectronic, as the responsible party for regulatory compliance, declares under our sole responsibility that as delivered the described product is in conformity with the RED Radio Equipment Directive 2014/53/EU, following the provisions of ERP Directive 2009/125/EC, EU RoHS Directive 2011/65/EU, including the amendment 2015/863/EU on the restriction of the use of certain hazardous substances in electrical and electronic equipment, and carries the CE-marking. Refer to [emmicroelectronic.com](http://emmicroelectronic.com) for the signed declaration.

##### 5.4.1.1. SAFETY File

1. Information on all plastics (flame rating and UL listing) model numbers
2. Battery: Specification, UL listing, and reports from vendor (Standards are UL 1642 and IEC/EN 62133)
3. PCB Board (same information as plastics)
4. Label (same information as plastics)

#### 5.4.2. Regulatory Information USA

Changes or modifications not expressly approved by the party responsible for compliance could void the user's authority to operate the equipment.

- Part 15 – General emissions
- Part 15.247:2011 – Operation within the band 2.4-2.4835GHz

This device complies with part 15 of the FCC Rules. Operation is subject to the following two conditions: (1) This device may not cause harmful interference, and (2) this device must accept any interference received, including interference that may cause undesired operation.

#### 5.4.2.1. Class A Device Notice

This equipment has been tested and found to comply with the limits for a Class A digital device, pursuant to part 15 of the FCC Rules. These limits are designed to provide reasonable protection against harmful interference when the equipment is operated in a commercial environment. This equipment generates, uses, and can radiate radio frequency energy and, if not installed and used in accordance with the instruction manual, may cause harmful interference to radio communications. Operation of this equipment in a residential area is likely to cause harmful interference in which case the user will be required to correct the interference at his own expense.

#### 5.4.2.2. RF Exposure Safety

The EMBC22 is a radio transmitter and receiver.

It is designed not to exceed the emission limits for exposure to radio frequency (RF) energy set by the Federal Communications Commission.

The antenna must be installed and operated with minimum distance of 20 cm between the radiator and your body.

This transmitter must not be co-located or operating in conjunction with any other antenna or transmitter.

#### 5.4.2.3. Permitted Antenna

This radio transmitter model, FCC ID: 2ACQR-EMBC22 has been approved by FCC to operate with the antenna types listed below with the maximum permissible gain indicated. Antenna types not included in this list, having a gain greater than the maximum gain indicated for that type, are strictly prohibited for use with this device.

Type	Max Gain
Integrated PCB IFA	1.5 dBi

#### 5.4.2.4. Labelling Requirements for the Host Device

The host device shall be properly labelled to identify the modules within the host device. The certification label of the module shall be clearly visible at all times when installed in the host device, otherwise the host device must be labelled to display the IC of the module, preceded by the words "Contains transmitter module", or the word "Contains", or similar wording expressing the same meaning, as follows:

Contains FCC ID: 2ACQR-EMBC22

#### 5.4.3. Regulatory Information Canada

Changes or modifications not expressly approved by the party responsible for compliance could void the user's authority to operate the equipment.

Les changements ou modifications non expressément approuvés par la partie responsable de la conformité pourraient annuler l'autorisation de l'utilisateur d'utiliser l'équipement.

This device complies with Industry Canada's licence-exempt RSSs. Operation is subject to the following two conditions: (1) This device may not cause interference; and (2) This device must accept any interference, including interference that may cause undesired operation of the device.

Le présent appareil est conforme aux CNR d'Industrie Canada applicables aux appareils radio exempts de licence. L'exploitation est autorisée aux deux conditions suivantes : (1) l'appareil ne doit pas produire de brouillage, et (2) l'utilisateur de l'appareil doit accepter tout brouillage radioélectrique subi, même si le brouillage est susceptible d'en compromettre le fonctionnement.

- ICES-003 – General emissions
- RSS-210:2010 – Low-power License exempt Radio Communication Devices

#### 5.4.3.1. RF Exposure Safety

The EMBC22 is a radio transmitter and receiver. It is designed not to exceed the emission limits for exposure to radio frequency (RF) energy set by the ISED. The antenna must be installed and operated

with minimum distance of 20 cm between the radiator and your body. This transmitter must not be co-located or operating in conjunction with any other antenna or transmitter.

Type	Max Gain
Integrated PCB IFA	1.5 dBi

Le EMBC22 est un émetteur et un récepteur radio. Il est conçu pour ne pas dépasser les limites d'émission pour l'exposition à l'énergie radiofréquence (RF) établie par l'ISDE. L'antenne doit être installée de façon à garder une distance minimale de 20 cm entre la source de rayonnements et votre corps. L'émetteur ne doit pas être colocalisé ni fonctionner conjointement avec à autre antenne ou autre émetteur.

Type	Max Gain
Integrated PCB IFA	1.5 dBi

#### 5.4.3.2. *Permitted Antenna*

This radio transmitter model, IC: 12155A-EMBC22 has been approved by the ISED to operate with the antenna types listed below with the maximum permissible gain indicated. Antenna types not included in this list, having a gain greater than the maximum gain indicated for that type, are strictly prohibited for use with this device.

Le présent émetteur radio modèle, IC: 12155A-EMBC22 a été approuvé par ISDE pour fonctionner avec les types d'antenne énumérés ci-dessous et ayant un gain admissible maximal. Les types d'antenne non inclus dans cette liste, et dont le gain est supérieur au gain maximal indiqué, sont strictement interdits pour l'exploitation de l'émetteur.

#### 5.4.3.3. *CAN ICES-3 (A/B)/NMB-3(A/B)*

This Class A/B digital apparatus complies with Canadian ICES-003

Cet appareil numérique de classe A/B est conforme à la norme Canadienne ICES-003

#### 5.4.3.4. *Labelling Requirements for the Host Device*

The host device shall be properly labelled to identify the modules within the host device. The certification label of the module shall be clearly visible at all times when installed in the host device, otherwise the host device must be labelled to display the IC of the module, preceded by the words "Contains transmitter module", or the word "Contains", or similar wording expressing the same meaning, as follows:

Contains IC: 12155A-EMBC22

L'équipement hôte doit être correctement étiqueté pour identifier les modules dans l'équipement. L'étiquette de certification du module doit être clairement visible en tout temps lorsqu'il est installé dans l'hôte, l'équipement hôte doit être étiqueté pour afficher l'IC du module, précédé des mots "Contient le module émetteur", ou le mot "Contient", ou un libellé similaire exprimant la même signification, comme suit:

Contains IC: 12155A-EMBC22



## 6. FIRMWARE

The following is a basic description of EMBC22 firmware functionality.

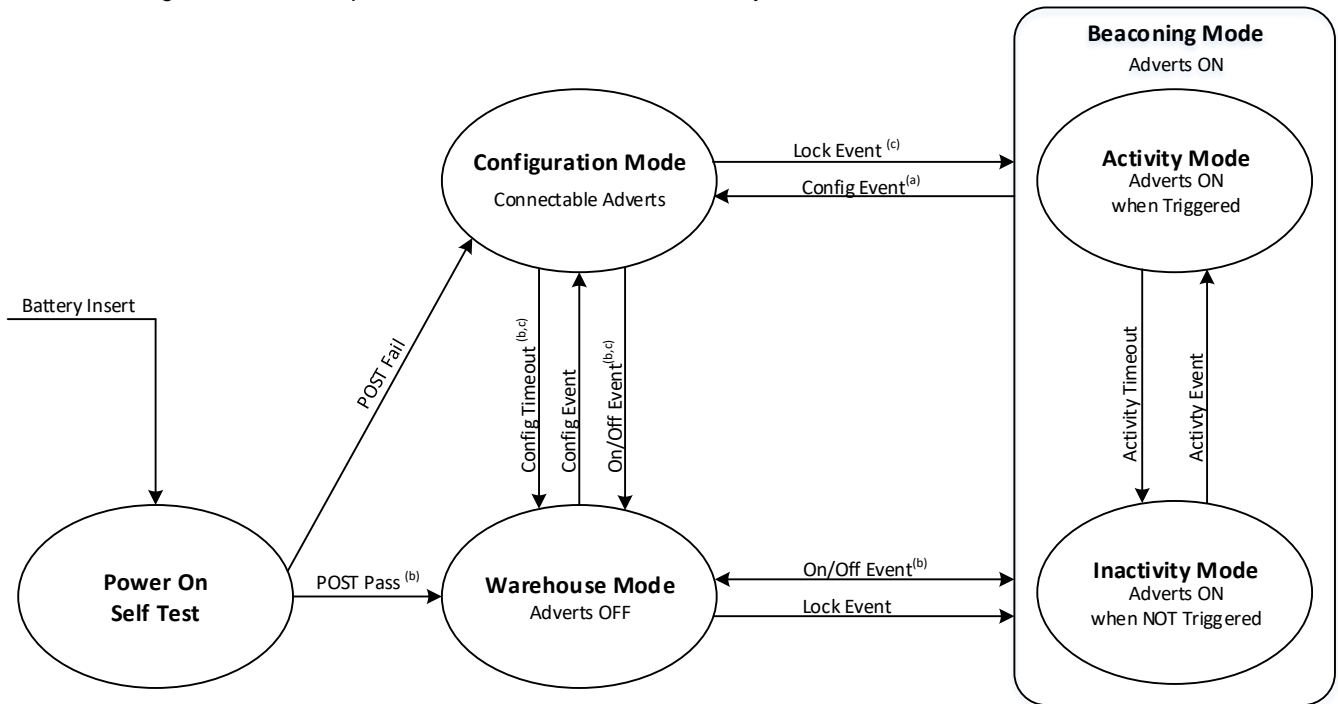

- (a) Event disabled after Lock Event occurs
- (b) Event can be configured transition to “Beaconing”, rather than “Warehouse” Mode
- (c) Disabled by POST failure

**Figure 3: Firmware State-Diagram**

### 6.1.1. State Machine Configuration Options

Table 8: State Machine Configuration Options		
Parameter	Options	Default
Hardware Features	Button Red LED Green LED Accelerometer	All Enabled
Startup Mode	Warehouse Mode Beaconing Mode	Warehouse Mode
Activity Event Source	Disabled Short Button Press Movement Tap Double Tap Freefall Flip	Movement
On/Off Event Source	Disabled Short Button Press Long Button Press Flip	Short Button Press
Configuration Event Source	Disabled Short Button Press Long Button Press Flip	Long Button Press
Lock Event	Lock Button Press	Lock Button Press
Configuration Timeout	0.1 to 6553.5 seconds	60 sec
Activity Timeout	0.1 to 6553.5 seconds	60 sec

### 6.1.2. Hardware Features

The hardware features of the button, Red LED, Green LED and Accelerometer may be disabled in firmware. The option to disable these hardware features is unavailable in the standard release of the Beacon Configuration Tool Suite. Options to control these features can be made available on request.

### 6.1.2.1. Button Press Duration

The button can be used to trigger up to three different events based on the duration that the button is pressed. Button presses are categorized as described in Table 9: Button Press Duration Options. A Short Button Press is any press of a duration less than a Long Button Press. A Long Button Press is any press longer than the Short Press Duration, but less than the Lock Press Duration.

Parameter	Press Duration Options	Default Press Duration
Short Button Press		-
Long Button Press	1000 to 4999ms	2000ms
Lock Button Press	5000 to 15000ms	10000ms

The duration of the Long and Lock button press may be modified. The option to modify the button press durations is unavailable in the standard release of the Beacon Configuration Tool Suite. These features can be made available on request.

### 6.1.3. Operating Modes

Operating Modes of the EMBC22 are indicated with boxes in the Figure 3: Firmware State-Diagram. The modes are fixed unless code patches are written and applied to redefine the states. Code patches may be developed using the EM Beacon SDK on the EMBC22 DVK. Behaviors within specific states, such as advertisement profiles in the Beaconsing Mode, can be redefined using the Beacon Configuration Tool Suite. No source code development is required when using the Beacon Configuration Tool Suite.

#### 6.1.3.1. Power-On-Self-Test (POST)

On battery insertion, a self-test feature is run to confirm functionality of the key electrical components for advertising. The self-test checks for hardware failures on the module. If the test passes, both LEDs will turn off. If the test fails, one or more of the LEDs will remain on in the present state to indicate which step failed. Table 10: POST Test Sequence shows the sequence of the tests and the illuminated LED that corresponds to the test that failed.

Feature Tested	Failure Mode LED Indicator
Accelerometer	Solid Red + Green LED
48MHz High Frequency Crystal	Solid Red LED
32kHz Low Frequency Crystal	Solid Green LED
Invalid Configuration	Flash Red LED

A set of invalid configuration options are checked after the hardware tests are complete. If an invalid configuration option is detected the device will disable the accelerometer and button and enter Configuration Mode. The red LED will flash in this state indicating that an invalid configuration has been loaded.

#### 6.1.3.2. Startup Mode

The startup mode is the mode that will be entered after POST or on a Configuration Timeout Event. The default definition of Startup Mode and reassignment options are as defined in Table 8: State Machine Configuration Options.

#### 6.1.3.3. Warehouse Mode

In Warehouse Mode, the EMBC22 is in its lowest consumption state to support long term storage. A Configuration Event, On/Off Event or Lock Event will all initiate exiting the Warehouse Mode. If a Configuration Event or On/Off Events are defined to use the flip option, the accelerometer will be sampling at the rate defined in the accelerometer configuration settings. The consumption will increase as defined in the Table 13: Accelerometer Configuration Options at the selected sampling rate. If the Configuration Event and On/Off Event are not defined to use the flip option, the accelerometer is in a power down state and the consumption of the device is as defined in *Table 4: Battery Life-Time and Range Use Case Example*

#### 6.1.3.4. Configuration Mode

In Configuration Mode, the EMBC22 advertises a connectable advertisement at the default interval and output power as defined in Table 11: Configuration Mode Advertisement Configuration Options. The advertisement rate and output power may be redefined by the user. The configuration timer is started on entry into the Configuration Mode. If no connections are made before the Configuration Timeout occurs, the EMBC22 returns to the startup state. Exit from Configuration Mode is initiated by an On/Off Event, Lock Event or Configuration Timeout. When a connection is made to the EMBC22, the part will stay in a

connected state until the master breaks the connection or is out of range. On disconnect, the EMBC22 returns to the previous state unless a reset was initiated during the connection.

Description	Supported Type	Default
Packet Type	Connectable	Connectable
Advertisement Interval	30ms - 18hrs <sup>(1)</sup>	500 ms
Tx Power Level Settings (dBm)	6.2 4.6 2.5 0.4 -1.4 -2.6 -4 -5.5 -6.9 -8.4 -9.9 -11.4 -13.1 -14.6 -16.4 -17.9 -29 -33.5	0.4 dBm

**6.1.3.5. Beaconing Mode**

In Beaconing Mode, the EMBC22 beaconing engine is enabled. The beaconing engine supports up to 10 advertisements running in parallel. Each advertisement may have a unique Packet Type, Advertisement Interval, and Transmit Power Level. In addition, each advertisement may be gated such that the advertisement is Always Enabled, Enabled Only When Active or Enabled Only When Inactive. Table 12: Beaconing Mode Advertisement Configuration Options shows the configuration options available for each advertisement.

Description of the transmit power level settings are from the EM9304 datasheet version 4.1. Additional details regarding the impact on the operating behavior, consumption and performance of the device can be found in the datasheet. Modifications to the transmit output power and advertisement interval can have a dramatic impact on battery life. Consult the EM9304 datasheet to calculate the full impact of changes.

Description	Supported Type	Default
Packet Type	iBeacon™ Eddystone UID™ Eddystone URL™ Eddystone TLM™ altBeacon™ Connectable User Defined – Fixed Payload	Advertisement 1-10 Disabled
Advertisement Interval	30ms - 18hrs <sup>(1)</sup>	Advertisement 1-10 Disabled
Transmit Power Level Settings (dBm)	6.2 4.6 2.5 0.4 -1.4 -2.6 -4 -5.5 -6.9 -8.4 -9.9 -11.4 -13.1 -14.6 -16.4 -17.9	Advertisement 1-10 Disabled

	-29 -33.5	
Advertisement Gating	Off Always Enabled Enabled when Active Enabled when Inactive	Off

The beacon engine combines the settings of the 10 defined advertisement to create an interleaved advertisement profile. Below is a diagram showing an example where three advertisements are enabled. Adv1 is an Eddystone™ URL packet type with an output power of 0dBm at a 1 second interval and a URL of www.Moving.com set to transmit when the module is moving. Adv2 is a Connectable advertisement with an output power of -14dBm at a 300ms interval and is always enabled. Adv3 is an Eddystone™ URL packet type with an output power of -5dBm at a 1.5 second interval and a URL of www.NotMoving.com set to transmit only when the module is not moving.

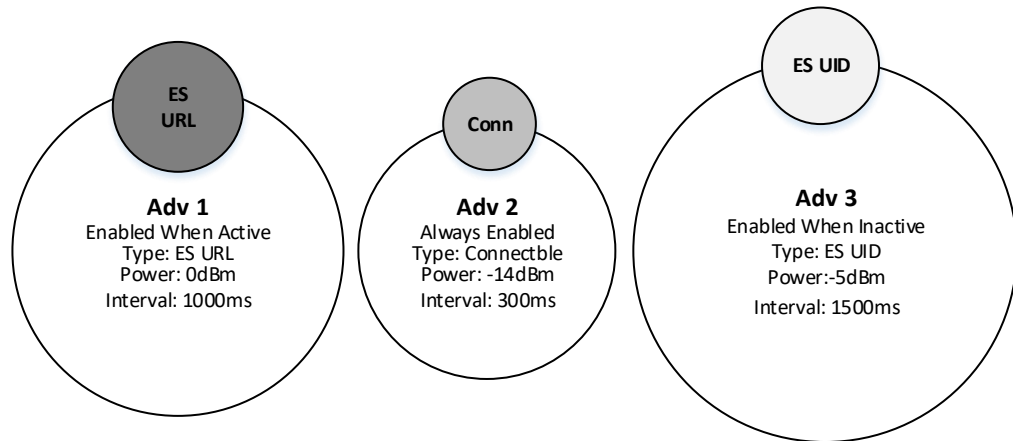

**Figure 4: Example of three advertisements enabled**

The beacon engine combines these three independent advertisement definitions to create appropriate interleaved advertisement profiles based on the Activity Events detected. The part is in an Inactivity Mode until an Activity Event is detected and the beacon engine manages interleaving the advertisement profiles is as shown in the figure below.

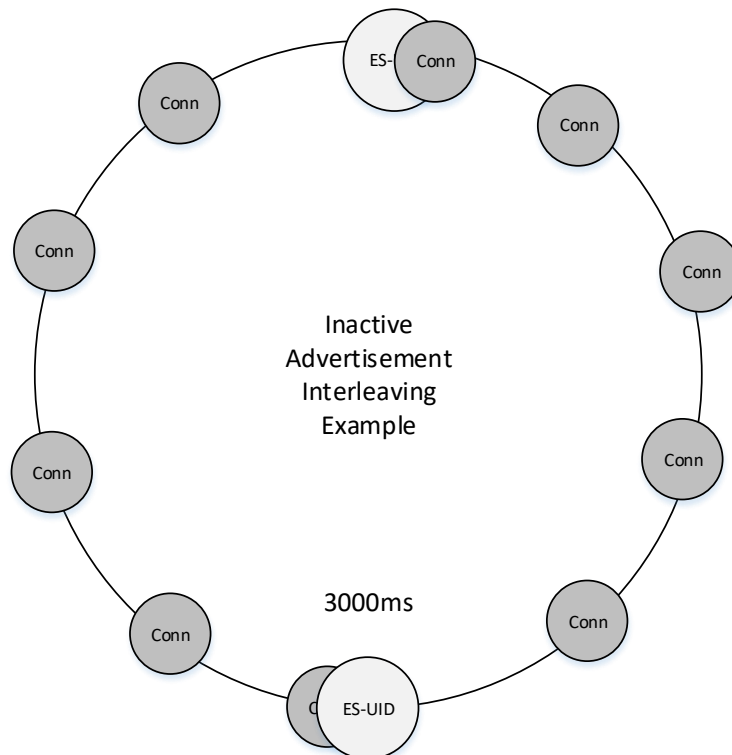

**Figure 5: Example advertisement interleaving in Inactivity Mode**

Once an Activity Event is detected, the beacon engine reengages to disable the On When Inactive advertisement and enable the On When Active advertisements. The resulting interleaved advertisement for profile in this example is shown below.

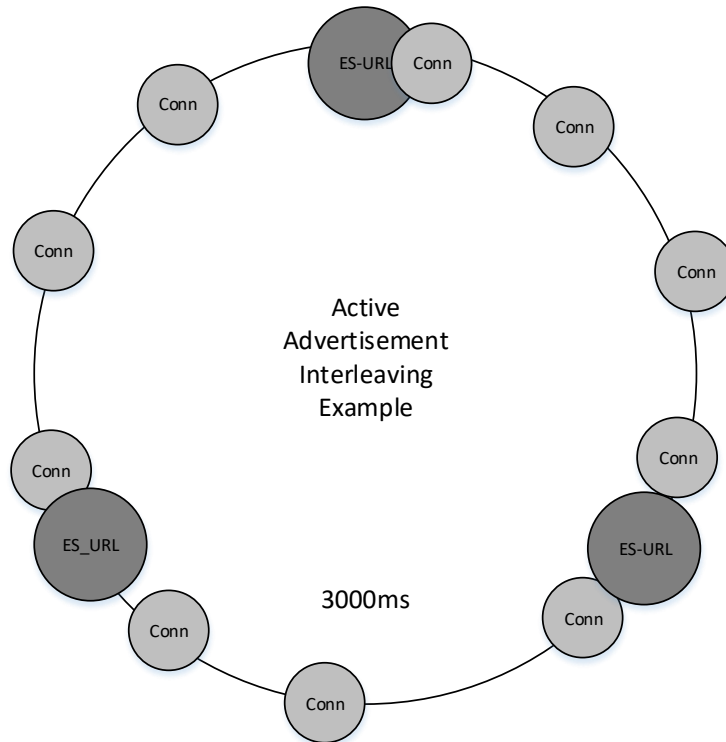

**Figure 6: Example advertisement interleaving in Activity Mode**

When multiple advertisements are running in parallel timing collisions may occur. The firmware will make priority decisions regarding which advertisement to send next. The advertising interval of one or more packets is extended by a minimum of 30ms when collisions occurs in order to prevent violation to BLE advertisement protocols.

**6.1.3.5.1. Activity Mode**

Activity Mode is a subset of Beaconsing Mode. When advertisements are assigned to this Advertisement Gating option, the advertisement will only occur after an Activity Event has been detected and for the duration of time defined by the Activity Timeout. Advertisements assigned to the Always Enabled advertisement gating option will continue to be transmitted while in the Activity Mode.

**6.1.3.5.2. Inactivity Mode**

Inactivity Mode is a subset of Beaconsing Mode. When advertisements are assigned to this advertisement gating option, the advertisement will only occur when not in the Activity Mode. Advertisements assigned to the Always Enabled advertisement gating option will continue to be transmitted while in the Inactivity Mode.

**6.1.3.6. BLE Connection**

A connection can be initiated from any mode where a connectable advertisement is sent. When a connection is made, all accelerometer interrupt sources are disabled. If the connection was made from Configuration or Activity Mode, the correlating timer continues to run while the connection is enabled. If the corresponding timer expires while the connection is enabled, the timeout event will occur on disconnect. Pressing the button during a connection will initiate a disconnect. If the corresponding timer does not expire while the connection is still enabled, the mode that the connection was initially made in will resume on disconnect. Specific services may initiate a Reset Event. Refer to Section 6.3 on the supported services for more details. A Reset Event will return the part to POST.

**6.1.4. Mode Transitions**

Mode transitions of the EMBC22 are indicated with arrows in the Figure 3: Firmware State-Diagram. The start and ending mode of transitions are fixed unless code patches are written and applied. Code patches may be written using the EM Beacon SDK and developed on the EM Beacon DVK. The duration of a Configuration

Timeout or an Activity Timeout can be redefined using the EM Beacon Configuration Tools. Additionally, the source of the Configuration Event and On/Off Event can be redefined using the EM Beacon Configuration Tools. No source code development is required when using the EM Beacon Configuration Tools.

#### 6.1.4.1. Configuration Event

A Configuration Event generates a transition from the Beaconsing Mode or Warehouse Mode into Configuration Mode. The Configuration Event may be assigned as defined in Table 11: Configuration Mode Advertisement Configuration Options using the EM Beacon Configuration Tools. No source code development is required when using the EM Beacon Configuration Tools.

If the Configuration Event is assigned to flip, the event will only be triggered when the module is rotated from the gravity vector pointing in the negative Z (1) direction to the gravity vector pointed in the positive Z direction.

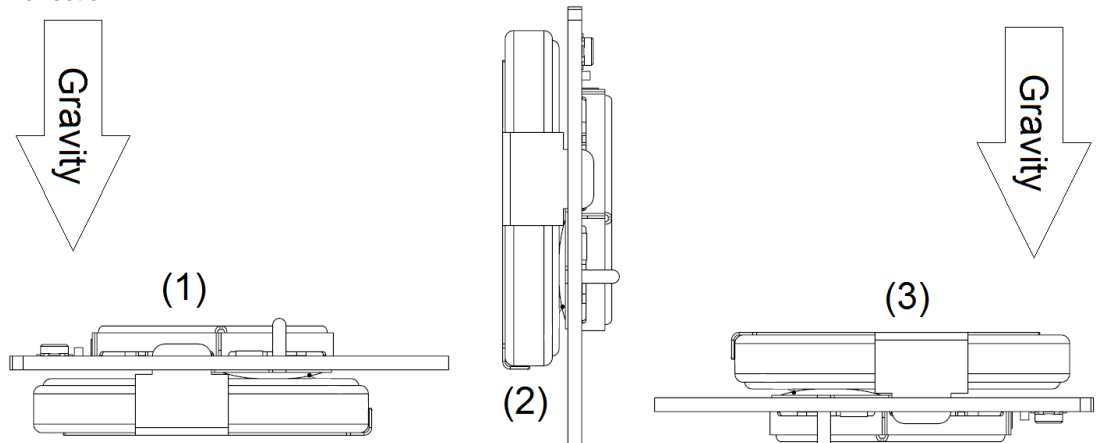

Figure 7: Configuration Event Flip Sequence

The Green LED flashes twice when a Configuration Event occurs.

#### 6.1.4.2. Configuration Timeout

On entry into the Configuration Mode, the configuration timer is started. A Configuration Timeout is generated when that timer expires and initiates a transition from Configuration Mode to the startup mode. The duration of the Configuration Timeout may be modified with the EM Beacon Configuration Tools as defined in Table 11: Configuration Mode Advertisement Configuration Options. No source code development is required when using the EM Beacon Configuration Tools.

The Red LED flashes twice when a Configuration Timeout occurs.

#### 6.1.4.3. On/Off Event

An On/Off Event generates a transition from the Beaconsing Mode to Warehouse Mode, from Configuration Mode to Beaconsing Mode and from Beaconsing Mode to Warehouse Mode. The On/Off Event may be modified as defined in Table 11: Configuration Mode Advertisement Configuration Options using the EM Beacon Configuration Tools. No source code development is required when using the EM Beacon Configuration Tools.

When the On/Off Event initiates transitioning to Beaconsing Mode, the Green LED is enabled while the event is occurring. When the On/Off Event initiates transitioning to Warehouse Mode, the Red LED is enabled while the event is occurring.

#### 6.1.4.4. Activity Event

No LED indicators are used to communicate transitions between Activity and Inactivity Mode.

#### 6.1.4.5. Activity Timeout

An Activity Event generates a transition from the Inactivity Mode to Activity Mode. The Activity Event may be assigned as defined in Table 11: Configuration Mode Advertisement Configuration Options.

On entry into the Activity Mode, the activity timer is started. An Activity Timeout is generated when the activity timer expires and initiates a transition from Activity Mode to the startup mode. The duration of the Activity Timeout may be modified with the EM Beacon Configuration Tools as defined in Table 11: Configuration Mode Advertisement Configuration Options. No source code development is required when using the EM Beacon Configuration Tools.

No LED indicators are used to communicate transitions between Activity and Inactivity Mode.

**6.1.4.6. Reset Event**

A Reset Event is initiated by battery insertion, toggling the enable signal from the test bus or from select BLE services. A Reset Event clears data RAM and returns to the POST state to reinitialize the part.

After a Reset Event the LED indicators of POST running will be seen.

**6.1.4.7. Lock Event**

A Lock Event will disable the On/Off Event and initiate a transition to Beaconsing Mode. The only way to exit beaconsing mode after an On/Off Event has been initiated is to issue a Reset Event.

The Green LED flashes three times when a Lock Event has been initiated.

**6.1.5. Accelerometer Configuration**

Configuration of key control registers on the accelerometer may be modified from the EM Beacon Configuration Tools. The configurable options are listed in Table 13: Accelerometer Configuration Options. Full descriptions of the parameter are available in the STM LIS2DWL datasheet (see DocID029682 Rev4). Additional details regarding the impact on the operating behavior, consumption and performance of the device can be found in the accelerometer datasheet.

<b>Table 13: Accelerometer Configuration Options</b>			
Description	Available Options	Default	Units
Output Data Rate	Power Down 1.6 12.5 25 50 100 200	12.5	Hz
Power Mode	Low Power High Performance	Low Power	-
Low Noise	Enable Disable	Disabled	-
Filter Bandwidth	Div 2 Div 4 Div 10 Div 20	Div 2	-
Full Scale Range	2 4 8 16	2	G
Filter Selection	Low Pass High Pass	Low Pass	-
Movement Threshold	0 to 63	4	Samples
Movement Duration	0 1 2 3	0	Sequential Samples
Flip 4D/6D	4D Detection 6D Detection	6D	-
6D Threshold	50 60 70 80	60	Degrees
6D Low Pass Filter	Enable Disable	Disable	-
Tap Shock X Threshold	0 to 31	9	-
Tap Shock Y Threshold	0 to 31	9	-
Tap Shock Z Threshold	0 to 31	9	-
Tap Shock Time	4 8 12 16	16	Samples
Tap Quiet Time	2 4	8	Samples



	6		
	8		
Double Tap Latency	16	128	Samples
	32		
	48		
	64		
	80		
	96		
	112		
	128		
	144		
	160		
	176		
	192		
	208		
	224		
	240		
	256		
Tap Axi	X Axis Y Axis Z Axis	All Enabled	-
Freefall Duration	0-63	3	Samples
Freefall Threshold	156	312	mg
	219		
	250		
	312		

Modifications to the accelerometer settings can have a dramatic impact on battery life. Consult the STM datasheet to calculate the full impact of changes to the accelerometer settings.

## 6.2. ADVERTISEMENTS

### 6.2.1. Device Address

Each EMBC22 has a unique factory-assigned address. The first 3 octets of the device address are the EM Microelectronic OUI assigned address from the IEEE 802 committee: 0x0CF3EE. The last 3 octets of the device address are uniquely assigned by EM Microelectronic. All advertisements enabled in the Beacons and Configuration Modes share the same Device Address.

The device address to be used may be modified with the EM Beacon Configuration Tools. If the address 00:00:00:00:00:00 is entered, then the factory-assigned address will be used.

### 6.2.2. Advertising Channels

Advertisements are transmitted on channel 37, 38 and 39. Firmware options to disable up to two of the three advertisement channels for non-connectable advertisements are available. The option to disable the advertisement channels is unavailable in the standard release of the Beacon Configuration Tool Suite. The features can be made available on request in Beacon Configuration Tool Suite. Disabling of advertisement channels is not compliant with Bluetooth specifications and compatibility with other BLE technology cannot be guaranteed when channels are disabled.

### 6.2.3. RSSI Table

The Eddystone™, iBeacon™ and altBeacon™ packet types include a one byte signed value that is used to communicate the signal strength of the packet being transmitted. This byte is retrieved from the RSSI Table in the EMBC22. The beacon engine will automatically retrieve the setting that correlates to the selected output power setting for the advertisement. Default values are assigned using the calibration procedure defined by Apple™ and an iPhone 4S™. The default settings are as defined in Table 14: RSSI Table.

Tx Power Level (dBm)	RSSI Table Entry (dBm at 1m)
6.2	-55
4.6	-57
2.5	-59
0.4	-61
-1.4	-63
-2.6	-64
-4	-66
-5.5	-67
-6.9	-68



-8.4	-70
-9.9	-71
-11.4	-73
-13.1	-75
-14.6	-76
-16.4	-78
-17.9	-79
-29	-91
-33.5	-95

The RSSI Table values may be modified using the EM Beacon Configuration Tools.

#### 6.2.4. *Connectable Advertisement*

These Bluetooth advertising packets are connectable, undirected advertising events (ADV\_IND) which follow the GAP specification according to the Bluetooth Specification V5.0, Volume 3, Part C, Section 11.

The friendly name used in the connectable advertisement may be redefined using the Beacon Configuration Tool Suite. If the friendly name is left blank in the Beacon Configuration Tool Suite, the name is automatically generated from the device address.

#### 6.2.5. *Non Connectable Advertisements*

These Bluetooth advertising packets are non-connectable, undirected advertising events (ADV\_NONCONN\_IND) which follow the GAP specification according to the Bluetooth Specification V5.0, Volume 3, Part C, Section 11.

##### 6.2.5.1. *iBeacon™ Format*

The format of the iBeacon™ packet is described in the following specification: Proximity Beacon Specification Release R1 Draft D1, which can be obtained from Apple, Inc.

The UUID, Major ID and Minor ID used in the iBeacon™ advertisement may be redefined using the Beacon Configuration Tool Suite. If the UUID is set to 0, the default UUID of 699EBC80-E1F3-11E3-9A0F-0CF3EE3BC012 is used. If both the Major ID and Minor ID are set to 0 in the Beacon Configuration Tool Suite, the Major ID and Minor ID are extracted from the lowest four bytes of the device address.

##### 6.2.5.2. *Eddystone™ UID, URL and TLM*

Refer to the Eddystone™ specifications available on GitHub for details on the payload of an Eddystone™ URL, Eddystone™ UID and Eddystone™ TLM packet.

The URL, UID Namespace and UID Instance used in the Eddystone™ advertisement may be redefined using the Beacon Configuration Tool Suite. If the URL parameter is left blank in the Beacon Configuration Tool Suite, the default URL of [www.emdeveloper.com](http://www.emdeveloper.com) is used. If the UID Namespace is set to 0 in the Beacon Configuration Tool Suite, the default UID Namespace value is 699E-BC80-E1F3-11E3-9A0F. If the UID Instance is set to 0 in the Beacon Configuration Tool Suite, the default UID Instance value is the device address.

##### 6.2.5.3. *AltBeacon™ Formats*

Refer to the AltBeacon™ specifications available on GitHub for details on the payload of an AltBeacon packet.

The UUID, Major ID and Minor ID used in the altBeacon™ advertisement may be redefined using the Beacon Configuration Tool Suite. If the UUID parameter is set to 0, the default UUID of 699EBC80-E1F3-11E3-9A0F-0CF3EE3BC012 is used. If the Major ID and Minor ID parameters are both set to 0 in the Beacon Configuration Tool Suite, the Major ID and Minor ID are extracted from the lowest 4 bytes of the device address.

##### 6.2.5.4. *User Defined Format*

A fixed payload of up to 31 bytes may be defined by the user. Compliance with BLE advertising specification and requirements are the responsibility of the user to maintain compatibility with third party BLE equipment.

### 6.3. SUPPORTED BLE SERVICES

### 6.3.1. *Firmware Over The Air (FOTA) Service*

Service UUID: 00007001-0000-0041-4c50-574953450000

The EM9304 Firmware Over-The-Air (FOTA) service allows the user to upload new configuration and code containers onto the EM9304. Containers may be uploaded into one of two memories: IRAM or OTP. In addition, the containers stored on the EM9304 may be listed and invalidated through the FOTA profile. The FOTA profile can also reset the part as well as turn off IRAM.

Details about the OTP, IRAM and patching are available in the Beacon User Guide.

The Implementer's Guide for the EM9304 FOTA service is available through the development support forums.

### 6.3.2. *Beacon Information Service*

Service UUID: F4000A80-DE94-078F-E311-35B1EE4FDB15

The Beacon Information Service is design to allow users to read the current configuration status of the module.

The protocol is a command-response. To use the service, the remote app writes a command to the Command Characteristic and reads the response from the Data Characteristic. Refer to the EM Beacon SDK for more details on the protocol.

#### 6.3.2.1. *Command Characteristic*

Characteristic UUID: F1000A80-DE94-078F-E311-35B1EE4FDB15

The Command Characteristic is a write-only characteristic. The complete list of commands is shown in Table 15: Beacon Information Service Commands.

Table 15: Beacon Information Service Commands		
Command	Description	Hex Code
Get Version	Request for the firmware version of the application.	0x01
Get Device Configuration	Request for the settings of the parameters in the Device Configuration tab of the Beacon Editor.	0x02
Get Advertising Configuration <n>	Request for the settings of the parameters in the Advert-x tab of the Beacon Editor.	0x03
Get Accelerometer Configuration	Request for the settings of the parameters in the Accelerometer Configuration tab of the Beacon Editor.	0x04
Get RSSI Table	Request for the settings of the parameters in the RSSI tab of the Beacon Editor.	0x05
Get Device Address	Request for the factory assigned Device Address	0x06

The format of the command is

<Command>    <Optional Parameter>    <Bytes to Follow>    <Optional Data>

#### 6.3.2.2. *Data Characteristic*

Characteristic UUID: F2000A80-DE94-078F-E311-35B1EE4FDB15

The Data Characteristic is a read-only characteristic. The format of the return is either the requested data or an error code. The first byte of the return is unique and indicates the type of response as defined in Table 16: Beacon Information Data Characteristic.

Table 16: Beacon Information Data Characteristic		
First Data Byte	Description	Hex Code
Error Response	A detailed error code and additional data if any follows.	0x80
Configuration Patch	This response can be saved as a binary file and used as a 9304 patch file. The beacon produces responses in this format when the request is for the Device Configuration, Advertisement Configuration, Accelerometer Configuration, or RSSI Table.	0x33
Command Echo	Echo of the command code that generated the data	All Others

### 6.3.3. Device Information Service

SIG Service Assigned Number: 0x180A

The Device Information Service is the standard service defined by the Bluetooth SIG. This service exposes manufacturer information about a device. The Device Information Service is instantiated as a Primary Service. Only one instance of the Device Information Service is exposed on a device. The service defines 9 characteristics. Usage for the 9 characteristics are detailed in Table 17: Device Information Service.

Table 17: Device Information Service			
Parameter	Default	Configurable	Assigned Number
Manufacturer Name	EM Microelectronic	Yes	0x2A29
Model Number	blank	Yes	0x2A24
Serial Number	Factory MAC Address	No	0x2A25
Hardware Revision	Unused	No	0x2A27
Firmware Revision	5A.00.01.00.00	No	0x2A26
Software Revision	Unused	No	0x2A28
System ID	Unused	No	0x2A23
Regulatory Certification List	Unused	No	0x2A2A
PnP ID	Unused	No	0x2A50

### 6.4. QUUPPA PROPRIETARY SYSTEM COMPATIBILITY

The EMBC22 can be made compatible with Quuppa proprietary following instruction provided on the EM support forum. Contact your local EM sales representative for further details.

## 7. UNIT LABEL

The label has the following contents:

- Model: EMBC22
- Unique Serial Number
- Contains FCC-ID: 2ACQR-EMBC22
- Contains IC ID: 12155A-EMBC22
- FCC and CE Marking
- EM Microelectronic company name
- QR Code containing the unique Serial Number

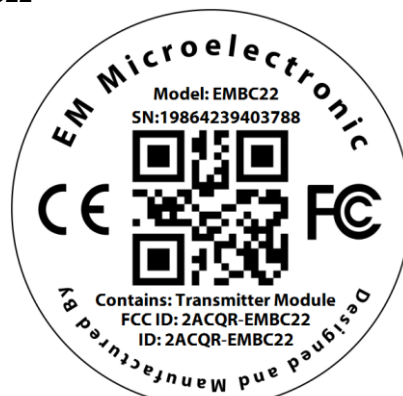

**Figure 8: Unit label**

## 7.1. SERIAL NUMBER

The serial number is generated by reading the device address of EMBC22, reversing the byte order, and printing the number in decimal form.

For example:

- Device Address: 0x0CF3EE001122 corresponds to Serial Number: 19864239403788

## 8. PACKING AND LABELING

### 8.1. FINISHED PRODUCT

#### 8.1.1. Inner Packing

EMBC22 beacons are packed in custom antistatic trays.

- Only one tray per box can have parts from 2 different product lots.
- Tray size is 300 x 261 x 38 mm.
- Number of parts per tray is 100pcs.
- There are 5 trays per stack, excluding cover tray.

A label is applied on each stack. The minimum information on the label is specified in Figure 9.

EM P/N:
Mfg date:
Module Lot Nr:
Qty:

**Figure 9: Packing label information**

#### 8.1.2. External Packing

Tray stacks are packed in cardboard box.

- Quantity of parts per box is 1000 pcs (2 tray stacks).
- Box dimensions are 37 x 55 x 43 cm.

A label is applied on each box. The minimum information on the label is specified in Figure 10.

EM P/N:
Mfg date:
Module Lot Nr:
Qty:
Weight:

**Figure 10: Panel packing label information**

## 9. ACCESSORIES

Please reference the EMBC01 datasheet for description of available accessories.

## 10. ENVIRONMENTAL SAFETY

EMBC22 is:

- RoHS compliant according to EU Directive 2011/65/EU and its amendments including 2015/863/EU
- Halogen Free according to IEC 61249-2-21:2003.
- REACH compliant according to EU Regulation 1907/2006

## 11. ORDERING INFORMATION

The EMBC22 is available as a finished product in a plastic housing with full FCC, IC, and CE certification. It is also available in PCB form as a panel which requires country certification (ie FCC, CE, etc.) of final product performed by the customer. The EMBC01 key-fob, wall-mount, and wrist-band accessories are available separately. Pre-certification beacons are available for evaluation and development. The EMBC22 Beacon Development Kit is available with 5 pre-certification beacons, an interface board, and JTAG cable for custom program development. The EMBC22 ordering information is shown in Figure 11 and the order numbers are shown in Table 18.

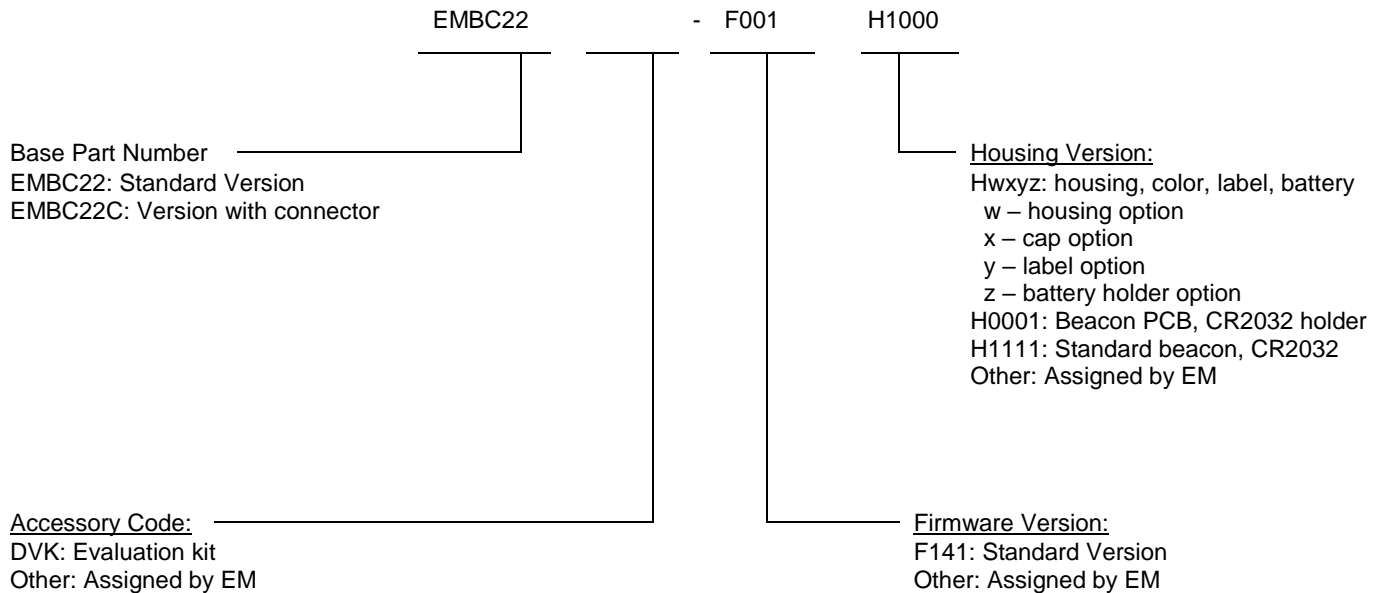

**Figure 11: EMBC22 Ordering Information**

**Table 18: EMBC22 Related Order Numbers**

ORDER NUMBER	DESCRIPTION	CONTAINER	UNITS PER CONTAINER	MINIMUM ORDER QUANTITY
EMBC22-F141-H1111	Standard Accelerometer beacon	Tray	100	100
EMBC22-F141-H0001	Accelerometer beacon PCB, CR2032 battery holder, switch, (no battery). Special conditions apply, please contact EM.	Tray	100	100
EMBC22DVK	EMBC22 Development Kit – includes 5 beacons with connectors	Box	1	1

## 12. CONTACT INFORMATION

**Inquiries for lead-times, quotes, orders:**

[EMDirect@emmicroelectronic.com](mailto:EMDirect@emmicroelectronic.com)

## 13. REFERENCE DOCUMENTS

- EMBC01 device specification
- EM9304 device specification
- LIS2DWL device Specification
- Bluetooth Specification V5.0
- Proximity Beacon Specification Release R1 Draft D



EM Microelectronic-Marín SA ("EM") makes no warranties for the use of EM products, other than those expressly contained in EM's applicable General Terms of Sale, located at <http://www.emmicroelectronic.com>. EM assumes no responsibility for any errors which may have crept into this document, reserves the right to change devices or specifications detailed herein at any time without notice, and does not make any commitment to update the information contained herein.

No licenses to patents or other intellectual property rights of EM are granted in connection with the sale of EM products, neither expressly nor implicitly.

In respect of the intended use of EM products by customer, customer is solely responsible for observing existing patents and other intellectual property rights of third parties and for obtaining, as the case may be, the necessary licenses.

**Important note: The use of EM products as components in medical devices and/or medical applications, including but not limited to, safety and life supporting systems, where malfunction of such EM products might result in damage to and/or injury or death of persons is expressly prohibited, as EM products are neither destined nor qualified for use as components in such medical devices and/or medical applications. The prohibited use of EM products in such medical devices and/or medical applications is exclusively at the risk of the customer.**

Bluetooth is a trademark of the Bluetooth SIG. iPad and iPhone are trademarks of Apple Inc., registered in the U.S. and other countries. Android is a trademark of Google Inc. Google Play is a trademark of Google Inc. Other product and company names mentioned herein may be trademarks of their respective companies.