



DUAL FREQUENCY RAINFC TRANSPONDER IC

DESCRIPTION

em|echo corresponds to the latest generation of EM Microelectronic contactless devices, bringing innovative features to the NFC and EPC™ worlds. The chip combines two functionalities on one single die, the EPC technology used for long range application purposes and the NFC used to exchange data in a proximity range. Both protocols may share a common unique ID.

Targeted applications and market segments include retail, product authentication or smart NFC posters.

A tag or label based on the em|echo provides multiple benefits and usages via the EPC communication interface like stock inventory, product returns, and data privacy. The same tag or label also enables new marketing services like product information or loyalty programs using an NFC enabled smartphone.

The chip is a dual frequency device supporting ISO/IEC14443 Type A, NFC Forum™ Type 2 specifications, ISO/IEC18000-63 and EPC Gen2 V2. Additional features have been added to provide chip privacy. For the NFC interface, the smart counter increments its value each time the NFC message has been read by the end-user.

Each chip is manufactured with a 96-bit unalterable unique identifier (UID) to ensure full traceability. The same UID number is used by both RF protocols. During an ISO/IEC14443 anti-collision procedure, the 7 bytes which are part of the 96-bit are sent back by the transponder IC.

The em|echo offers two non-volatile memories which are accessible by both RF air interfaces. The two memories are segmented to implement multiple applications.

em|echo supports the optional *BlockWrite* command, enabling the fast encoding of a 96-bit EPC. em|echo also supports the optional *Untraceable* command to hide portions of memory of the tag or label.

FEATURES

- | Dual Frequency 1-step inlay manufacturing
- | Shared unique ID
- | Shared memory
- | Minimum 100k write cycles endurance
- | Minimum 10 years data retention
- | Extended temperature range: -40°C to +85°C
- | Sawn wafers, 6-mil thickness, gold bumps

NFC INTERFACE

- | ISO/IEC 14443A -3 compliant tag
- | NFC Forum Type 2 compatible
- | Enables NDEF data structure configurations
- | Communication baud rates at 106kbps
- | Anti-tearing support for NFC capability container (CC) and Static/Dynamic lock bytes
- | ACCESS counter increased at first reading
- | Optional limit of unsuccessful LOGINs
- | Optional security timeout for unsuccessful LOGINs
- | Optional control of EPC privacy features
- | UHF power detection
- | 50pF NFC on-chip resonant capacitor

EPC INTERFACE

- | ISO/IEC 18000-63 compliant
- | EPC Gen2 V2 certified
 - Alteration EAS certified
 - Tag Alteration (Core) certified
- | 32-bit Access and Kill passwords
- | Read sensitivity up to -18dBm with a dipole antenna
- | Write sensitivity up to -13dBm with a dipole antenna
- | Fast writing using the *BlockWrite* command
- | Block permalock for USER memory
- | NFC field detection
- | NFC ACCESS counter

MEMORY

- | 32-bit Shared unique ID included in:
 - 7 bytes UID (NFC)
 - 96-bit TID (EPC)
- | 2080-bit or 1984-bit User memory
 - 1920 bit contiguous user data from NFC
 - 160 or 64 bit USER contiguous data from EPC
- | 128-bit or 224-bit UUI/EPC encodings
- | 1 step encoding possible from NFC or EPC interface.



RAIN RFID is a trademark of the RAIN RFID Alliance.

EPC is a trademark of EPCglobal Inc.



APPLICATIONS

- | Product Identification
- | Customer engagement, coupons, loyalty programs
- | Inventory and supply chain management
- | Asset control
- | Single tap quick re-ordering

TYPICAL OPERATING APPLICATION

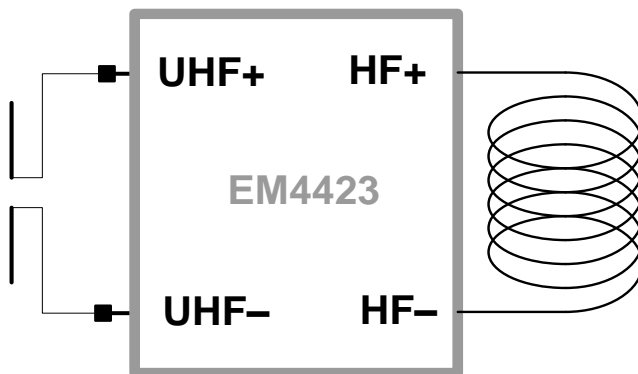



SYMBOLS, ABBREVIATED TERMS AND NOTATION

AC	Anticollision
ATQA	Answer To reQuest, Type A
BCC	Block Check Character (UID CLn check byte), Type A
BLF	Backscatter Link Frequency (EPC)
CC	Capability Container
CRC_A	Cyclic Redundancy Check error detection code, Type A
E	End of communication, Type A
FDT	Frame Delay Time PCD to PICC, Type A
fa	UHF carrier frequency
fc	HF carrier frequency
HLTA	HaLT command, Type A
lsb	Least Significant Bit
LSB	Least Significant Byte
msb	Most Significant Bit
MSB	Most Significant Byte
P	Odd Parity bit, Type A
PCD	Proximity Coupling Device
PICC	Proximity Card or object
REQA	REQuest command, Type A
RFU	Reserved for Future Use (always understood as '0' if not mentioned differently)
S	Start of communication, Type A
SAK	Select AcKnowledge, Type A
SEL	SElect code, Type A
WUPA	Wake-UP command, Type A

REFERENCES

- [\[ISO_14443_3\]](#) *ISO/IEC 14443-3 (Type A) – Initialization and anti-collision*
- [\[NFC_T2TOP\]](#) *NFC Forum Type 2 Operation Technical Specification, Version 1.1*
- [\[NFC_DIGITAL\]](#) *NFC Forum Digital Protocol Technical Specification, Version 1.0*
- [\[NFC_NDEF\]](#) *NFC Forum Data Exchange Format Technical Specification, Version 1.0*
- [\[ISO_18000_63\]](#) *ISO/IEC 18000-63 : Information technology – Radio frequency identification for item management – Part 63: Parameters for air interface communications at 860 MHz to 960 MHz Type C*
- [\[EPC_Gen2v2\]](#) *“EPC™ Radio-Frequency Identity Protocols, Generation-2 UHF RFID, Specification for RFID Air Interface Protocol for Communications at 860 MHz - 960 MHz, Version 2.0.1 Ratified” from EPCglobal Inc., April 2015*
- [\[EPC_TDS\]](#) *“EPC Tag Data Standard, GS1 Standard, Version 1.9, Ratified, Nov-2014” from EPCglobal Inc.*



TABLE OF CONTENTS

- 1. Block Diagram6
- 2. Electrical specifications.....7
 - 2.1. Absolute Maximum Ratings7
 - 2.2. Handling Procedures7
 - 2.3. Operating Conditions7
 - 2.4. Electrical Characteristics – NFC Forum Type 2 Contactless Interface8
 - 2.5. Electrical Characteristics – EPC Contactless Interface.....8
 - 2.6. NVM Electrical Characteristics8
 - 2.7. Timing Characteristics – NFC Forum Type 2 Contactless Interface9
 - 2.8. Timing Characteristics - EPC Contactless Interface9
- 3. Product overview 10
 - 3.1. Overview (NFC) 10
 - 3.2. Overview (EPC) 10
 - 3.3. Memory Access Arbitration 10
 - 3.4. Functional Description 11
 - 3.4.1. State diagram 11
 - 3.4.2. States description 11
- 4. NFC Functional Description 12
 - 4.1. State diagram 12
 - 4.1.1. States description 13
 - 4.1.2. Proprietary options and features..... 14
- 5. NFC Memory organization 15
 - 5.1. EPC Memory Mapping for Small EPC 16
 - 5.2. EPC Memory Mapping for Large EPC 16
 - 5.3. Memory Content at Delivery 17
 - 5.4. Detailed Memory description 18
 - 5.4.1. Static Lock bytes 18
 - 5.4.2. Capability container (CC)..... 19
 - 5.4.3. NFC User memory..... 19
 - 5.4.4. EPC mapped memory 19
 - 5.4.5. Gen2V2config Word 19
 - 5.4.6. Dynamic Lock bytes 21
 - 5.4.7. IC Configuration 0 word..... 22
 - 5.4.8. IC Configuration 1 word..... 23
 - 5.4.9. IC Configuration 2 word..... 23
 - 5.4.10. IC Configuration 3 word..... 25
 - 5.4.11. 4 Byte Password..... 26
 - 5.4.12. PACK..... 26
 - 5.4.13. 2 Byte Password..... 26
 - 5.4.14. 32 Byte Signature 26
 - 5.4.15. NFC sharing “read” Lock Bytes 27
 - 5.4.16. NFC sharing “write” Lock Bytes 28
 - 5.4.17. EPC sharing “read” Lock Bytes 28



5.4.18. EPC sharing “write” Lock Bytes	30
6. NFC Command set	31
6.1. Summary of commands	31
6.2. Commands and states	31
6.2.1. Timing	32
6.2.2. ISO14443-3 commands	32
6.2.3. ACK and NACK responses	32
6.3. NFC commands	33
6.3.1. Proprietary commands	36
7. EPC functional description	39
7.1. EPC memory organization	39
7.2. EPC Gen2 V2 - Small EPC memory map	40
7.3. EPC Gen2 V2 - Large EPC memory map	41
7.4. NFC Memory Mapping	42
7.5. EPC Gen2 V2 Delivery State	43
8. EPC Gen2 V2 Commands	43
8.1. Write operations using the Tag Notification (TN) indicator	44
8.2. EPC Privacy Features	44
9. Pad location diagram	45
9.1. Pin description	45
10. Ordering Information	46
10.1. Versions	46
10.2. Standard Versions and Samples	46
11. Product Support	47



1. BLOCK DIAGRAM

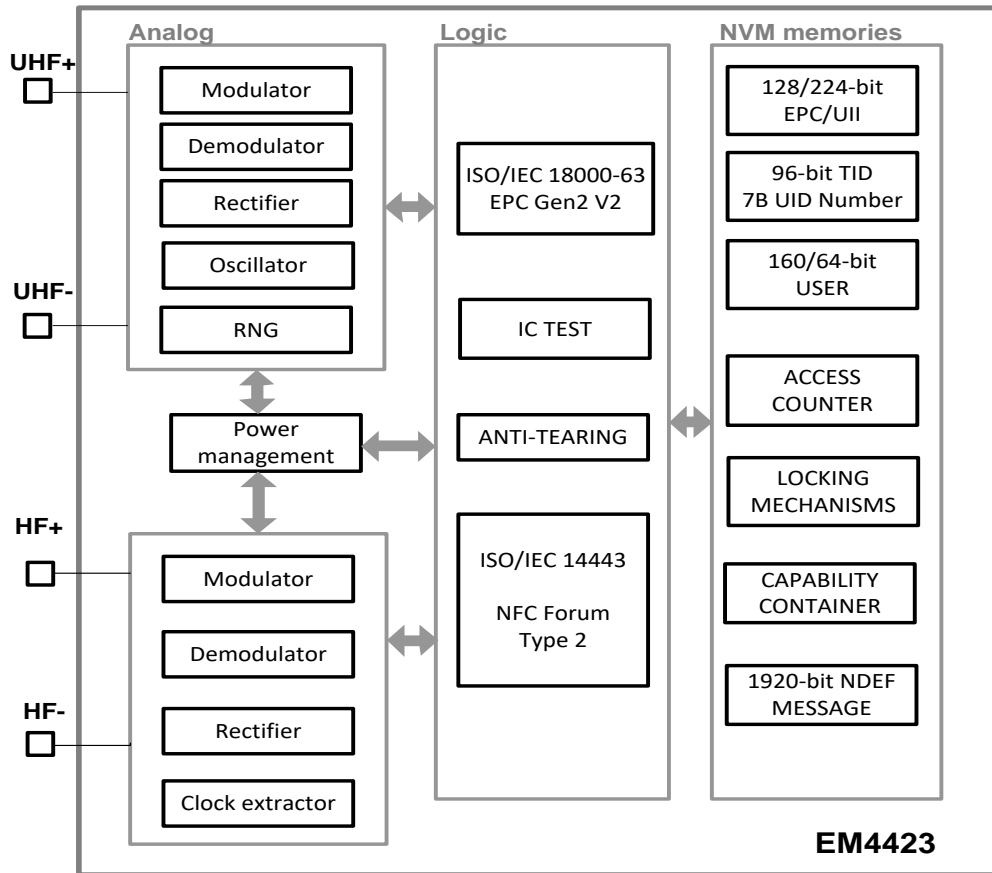



2. ELECTRICAL SPECIFICATIONS

2.1. ABSOLUTE MAXIMUM RATINGS

Parameters	Symbol	Min.	Max.	Unit
Storage temperature	T _{STORE}	-50	125	°C
RF power at pads UHF+,UHF- ¹⁾	P _{A_ABS}		25	dBm
Maximum AC current induced on HF+, HF-	I _{coil_RMS}		50	mA
ESD hardness pad UHF+, UHF-, HF+ and HF- ²⁾	V _{ESD}	-2000	2000	V

Note 1: IC impedance matched to antenna at read sensitivity (P_{RD_UHF})

Note 2: Human Body Model, all combinations between pins UHF+, UHF-, HF+, HF-.ESD measurements are made using die having VSS that is mounted into CDIP packages.

Stresses above these listed maximum ratings may cause permanent damages to the device. Exposure beyond specified operating conditions may affect device reliability or cause malfunction.

2.2. HANDLING PROCEDURES

This device has built-in protection against high static voltages or electric fields; however, anti-static precautions must be taken as for any other CMOS component. Unless otherwise specified, proper operation can only occur when all terminal voltages are kept within the voltage range. Unused inputs must always be tied to a defined logic voltage level.

2.3. OPERATING CONDITIONS

Parameters	Symbol	Min.	Max.	Unit
Operating temperature	T _{OP}	-40	+85	°C
RF power at pad UHF+, UHF- ¹⁾	P _A		20	dBm
RF carrier frequency	f _A	860	960	MHz
AC peak current induced on HF+, HF- in operating conditions	I _{coilop}		30	mA

Note 1: IC impedance matched to antenna at read sensitivity (P_{RD_UHF})



2.4. ELECTRICAL CHARACTERISTICS – NFC FORUM TYPE 2 CONTACTLESS INTERFACE

Operating conditions (unless otherwise specified): $V_{coil} = 4V_{pp}$, $V_{SS} = 0V$, $f_c = 13.56MHz$ sine wave, $T_{op} = 25^{\circ}C$

Parameters	Symbol	Conditions	Min.	Typ.	Max.	Unit
Resonance Capacitor – 50pF version	C_{r50}	$f_c = 13.56MHz$ $U = 2V_{rms}$	47.5	50	52.5	pF
Operating frequency	f_c		-	13.56	-	MHz

2.5. ELECTRICAL CHARACTERISTICS – EPC CONTACTLESS INTERFACE

Operating conditions (unless otherwise specified): $T_A = 25^{\circ}C$.

Parameters	Symbol	Conditions	Min.	Typ.	Max.	Unit
Incoming RF carrier modulation	K_M		65		100	%
Chip input capacitance	C_p	Parallel	-	0.67	-	pF
Chip impedance	Z_{AB}	866MHz ¹⁾²⁾	-	19.8-j273	-	Ω
		915MHz ¹⁾²⁾	-	18.1-j260	-	Ω
		960MHz ¹⁾²⁾	-	17.4-j248	-	Ω
Typical assembled impedance ³⁾	Z_{ass}	915MHz ⁴⁾	-	10.7-j200	-	Ω
Resistive load (between UHF+ and UHF-) when modulator is on	R_{B_ON}	1mA between pads	-	50	-	Ω
IC read sensitivity, UHF memory	P_{RD_UHF}	$f_A = 866MHz$ $f_A = 915MHz$	-	-16 ⁵⁾⁶⁾⁷⁾ -16 ⁵⁾⁶⁾⁷⁾	-	dBm dBm
IC read sensitivity, HF memory	P_{RD_HF}	$f_A = 866MHz$ $f_A = 915MHz$	-	-14 ⁵⁾⁶⁾ -14 ⁵⁾⁶⁾	-	dBm dBm
IC write sensitivity, UHF memory	P_{WR_UHF}	$f_A = 866MHz$ $f_A = 915MHz$	-	-11 ⁵⁾⁶⁾ -11 ⁵⁾⁶⁾	-	dBm dBm
IC write sensitivity, HF memory	P_{WR_HF}	$f_A = 866MHz$ $f_A = 915MHz$	-	-10 ⁵⁾⁶⁾ -10 ⁵⁾⁶⁾	-	dBm dBm

Note 1: Measured with a 100 Ω differential network analyzer directly on wafer**Note 2:** At Minimum operating power without command**Note 3:** The antenna should be matched to this impedance**Note 4:** Assuming 200fF additional input capacitance**Note 5:** IC impedance conjugate matched to antenna at read sensitivity (P_{RD_UHF})**Note 6:** 25 us TARI, 256 KHz BLF, Miller 4 encoding**Note 7:** Power to process a *Query* command

2.6. NVM ELECTRICAL CHARACTERISTICS

Parameters	Symbol	Conditions	Min.	Typ.	Max.	Unit
Erase / write endurance	T_{CYC}		100k			Cycles
Retention	T_{RET}	$T_{OP} = 55^{\circ}C$	10			Years



2.7. TIMING CHARACTERISTICS – NFC FORUM TYPE 2 CONTACTLESS INTERFACE

The time between the end of the last pause transmitted by PCD and the first modulation edge within the start bit transmitted by PICC is defined as follows for data rate $f_c/128$:

Last PCD bit = (1)b

$$(N \times 128 + 84) / f_c \text{ [ms]}$$

Last PCD bit = (0)b

$$(N \times 128 + 20) / f_c \text{ [ms]}$$

Symbol	minimum time [N]	maximum time [N, ms]
T _{NACK}	9	9
T _{READ}	9	≥ 9; ~5 ms
T _{WRITE}	9	≥ 9; ~10 ms
T _{SECTOR_SELECT}	9	9
T _{READ_COUNTER}	9	≥ 9; ~5 ms
T _{EN_DIS_PRIVACY}	9	≥ 9; ~10 ms
T _{LOGIN}	9	≥ 9; ~5 ms

Note: The NFC memory write operation timing can differ depending on the current content and data being written, it means that PICC can reply in different timeslots.

2.8. TIMING CHARACTERISTICS - EPC CONTACTLESS INTERFACE

The timings are according to [EPC_Gen2v2].

Note: The EPC memory write operation timing can differ depending on the current content and data being written.

Note: The EPC read operation for NFC memory is limited to a maximum data rate of 256Kbps. Using data rates above 256Kbps will result in read operations returning an error code.



3. PRODUCT OVERVIEW

3.1. OVERVIEW (NFC)

The em|echo corresponds to the latest generation of NFC devices offering innovative and enriched features. The em|echo supports ISO/IEC 14443-3 Type A standard with data rate at 106kbps and complies with the NFC Forum Type 2 specification.

The NFC memory offers R/W user's memory structured by segments and memory pages. The NFC memory contains the NFC capability container, the NDEF message and other proprietary data.

The em|echo offers the maximum of flexibility in terms of security. The user has also the possibility to select a 4-byte password with an optional and programmable limit of unsuccessful trials.

Each em|echo chip is delivered with a unique 7-byte ID number programmed at wafer level.

The NFC memory is also accessible through EPC interface as specified later on.

The NFC specific mechanisms and features don't influence EPC functionality excluding memory sharing and mechanisms which are explicitly described.

3.2. OVERVIEW (EPC)

The em|echo is an EPC RFID IC compliant with ISO/IEC 18000-63 and EPC Gen2 V2. It supports the core Tag Alteration and Alteration EAS application requirements to provide data privacy and EAS capability.

Each chip is provided with a 96-bit inalterable unique identifier to ensure full traceability. The em|echo is providing two optional configurations of the memory. (128-bit EPC+160-bit USER or 224-bit EPC + 64-bit USER) In both cases also 16-bit PC, 32-bit kill password, and 32-bit access password, and the support of ISO or EPC data structures.

The em|echo achieves a typical read sensitivity of -16 dBm at IC level (25us TARI, 256KHz BLF, Miller 4 encoding), and a typical write sensitivity of -11 dBm.

em|echo supports the optional *BlockWrite* command, enabling rapid EPC encoding.

The EPC memory is also accessible through NFC interface as specified later on.

The EPC specific mechanisms and features don't influence NFC functionality excluding memory sharing and mechanisms which are explicitly described.

3.3. MEMORY ACCESS ARBITRATION

The NFC and EPC interfaces have access to both the NFC memory and the EPC memory. No priority is given to either air interface. The memories cannot be accessed in parallel and memory access arbitration is performed on a per command basis as they are received over the air interfaces.



3.4. FUNCTIONAL DESCRIPTION

3.4.1. STATE DIAGRAM

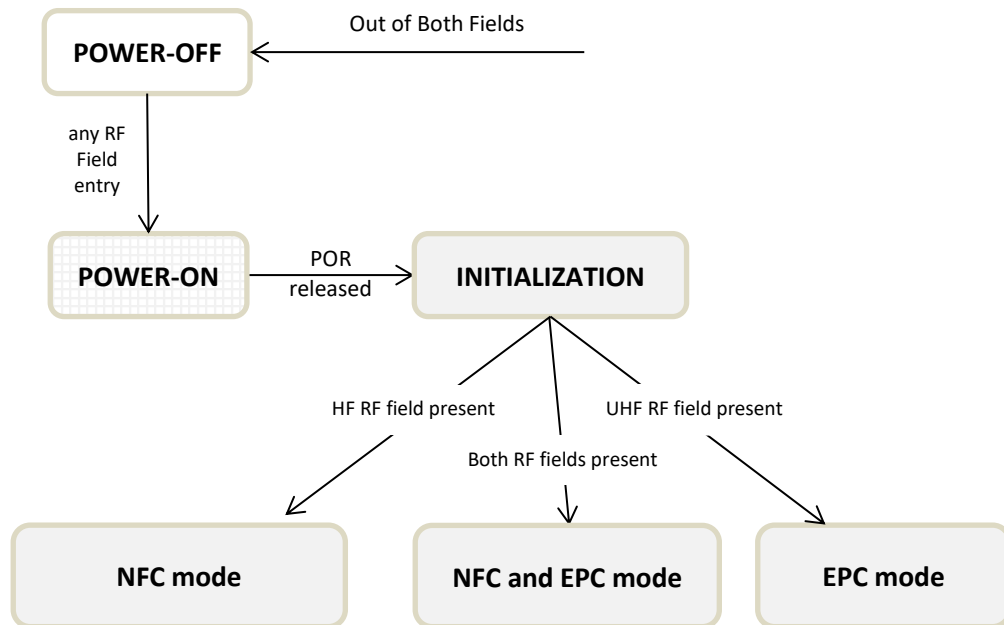

3.4.2. STATES DESCRIPTION

As soon as the em|echo enters RF operating field (HF or UHF), the energy from the operating field is extracted to power the em|echo. It's not distinguished if HF or UHF field is present. Also both fields can be present at the same moment.

Firstly the Power-On is released and then the em|echo initialization follows by reading initial values from NVM memory during INITIALIZATION. The em|echo stays quiet and ignores all incoming communication.

If UHF field is present EPC mode is available (if not killed) after INITIALIZATION and EPC interface is ready to execute commands.

If HF field is present NFC mode is available after INITIALIZATION and NFC interface is ready to execute commands.

If both fields are present NFC mode and EPC mode are available and will execute commands in the first in first served basis.

4. NFC FUNCTIONAL DESCRIPTION

4.1. STATE DIAGRAM

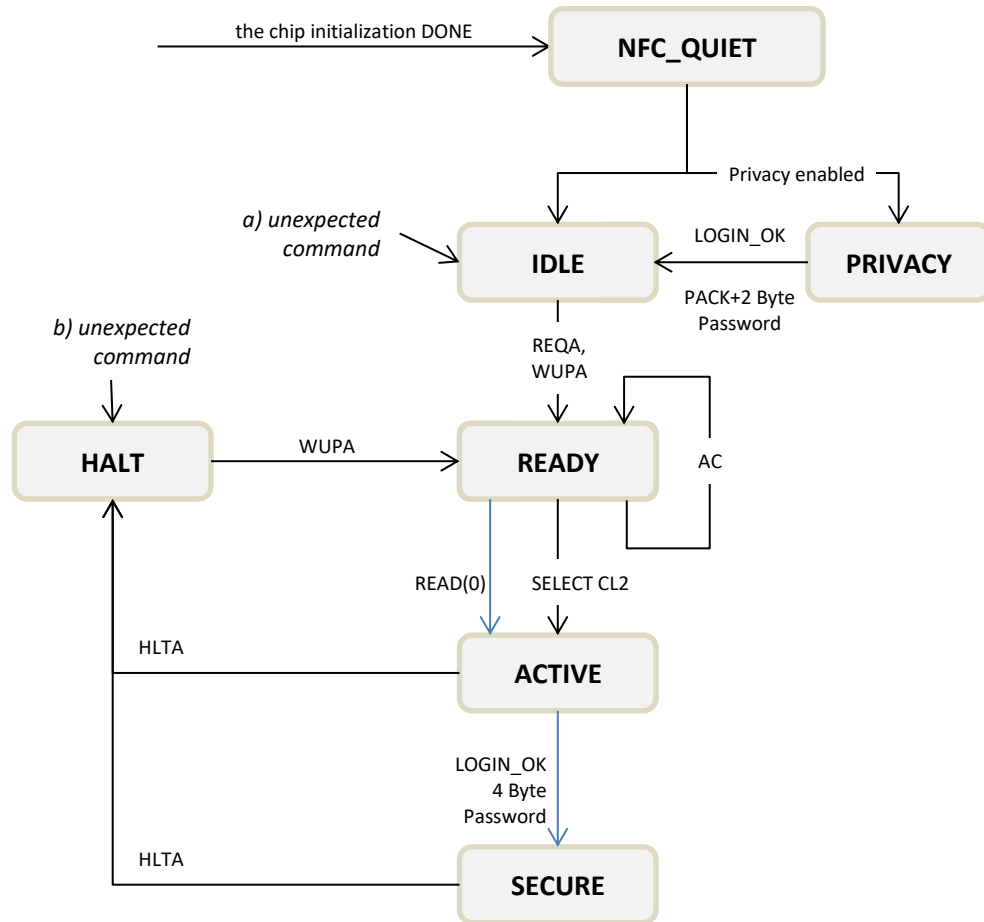

Not mentioned transitions are described in the below text:

- a) There is the transition to IDLE state if *unexpected* command is detected and the em|echo is in READY or ACTIVE or SECURE state and if em|echo was never been before in the HALT state.
- b) There is the transition to HALT state if *unexpected* command is detected and the em|echo is in READY or ACTIVE or SECURE state and if em|echo was at least once in the HALT state.

The following symbols apply for the state diagram above:

AC	ANTICOLLISION command (matched UID)
SELECT CL2	SELECT Cascade Level 2 command (matched UID)
REQA, WUPA, HLTA	ISO/IEC 14443-3 commands
unexpected	transmission error detected or unexpected frame
READ(0)	NFC Forum Type 2 READ command from block address 0



4.1.1. STATES DESCRIPTION

NFC_QUIET

The em|echo is powered and after INITIALIZATION it listens for commands in this state.

IF privacy mode is selected then there is transition to PRIVACY state

ELSE transition to IDLE state.

PRIVACY

In the PRIVACY state it waits for successful LOGIN command and then there is transition to IDLE state.

During PRIVACY the em|echo is not replying to any ISO14443 communication during this state.

IDLE

In the IDLE state it listens for commands. The only REQA and WUPA commands are valid in this state to reach READY state.

See also [ISO_14443_3].

READY

In the READY state, the bit frame anti-collision method shall be applied. Cascade levels are handled inside this state to get the complete UID. If SELECT CL2 is completed then there is transition to ACTIVE state.

The ACTIVE state is reached also after READ command with parameter addressing block 0. If more PICCs are responding at the same moment to READ(0) then PCD can see the collision because as part of the answer message is unique UID and PCD can continue accordingly. READ(0) can be initiated by PCD in any stage inside READY state.

See also [ISO_14443_3].

HALT

This state is reached after HLTA command received in ACTIVE or SECURE states.

The only WUPA command can initiate the transition from HALT state to READY state. Any other commands received in HALT state are interpreted as an error and em|echo remains in HALT state.

During HALT the em|echo stays quiet and ignores all incoming communication except WUPA command.

See also [ISO_14443_3].

ACTIVE

In ACTIVE state the em|echo is selected to communicate with PCD. Operations over memory are performed with respect to lock bits.

SECURE

The successful authentication by LOGIN provides the em|echo to SECURE state. It enhances the em|echo to provide additional services which are not allowed in the ACTIVE state.

Following services are additionally specified in SECURE state:

- change password
- the PWD_PROT_ADDR address protection is ignored (like 7Fh set)
- PRIVACY

SECURE state is lost when:

- Power down
- Unexpected command
- HLTA command



4.1.2. PROPRIETARY OPTIONS AND FEATURES

PRIVACY

This option is represented by PRIVACY state where the successful LOGIN command is expected. The em|echo replies only to the successful authentication by LOGIN command in this state. It allows avoiding any chip tracking if needed. The chip is invisible for any reader. The Privacy option can be enabled or disabled by the EN_DIS_PRIVACY command in SECURE state. The new configuration is valid after next chip Power-up.

ACCESS COUNTER

ACCESS counter represents a counter which is incremented once after Power-up when the first READ command is received. This option can be enabled or disabled by the appropriate configuration bit.

The ACCESS counter is anti-tearing mechanism proof.

If the ACCESS counter reaches maximum value (100 000 decimal) then next incrementations are blocked.

A status of the counter can be read by READ_COUNTER command.

The ACCESS counter is available also through memory sharing via EPC interface.

MEMORY PROTECTION

The memory can be protected against writing and/or reading.

It is controlled by:

- Static Lock bits
- Dynamic lock bits
- Password protection address
- Sharing Lock Bytes
- SECURE vs ACTIVE state

LIMIT OF UNSUCCESSFUL LOGINS

The number of unsuccessful password authentications, in ACTIVE state, can be optionally limited. When the limit specified by PWD_LIM is reached then a security timeout (100 ms typical) is initiated and any following LOGIN is ignored until the security timeout has expired. If the unsuccessful LOGIN counter is disabled then security timeout is ignored.

If the successful LOGIN is received before internal counter saturated then internal counter is cleared and there is again available maximum number of attempts defined by PWD_LIM.

In PRIVACY state this feature is not available.



5. NFC MEMORY ORGANIZATION

The memory is divided in blocks containing 4 bytes each.

NFC Block Address (decimal)	Bytes Within a Block				Access Type (unless password protected or locked)	Memory Type
	MSB Byte 0	Byte 1	Byte 2	LSB Byte 3		
0	UID0	UID1	UID2	BCC0	Read Only	NVM NFC
1	UID3	UID4	UID5	UID6		
2	BCC1	RFU	Static Lock0	Static Lock1	Read & Write 1's	NVM NFC
3	CC0	CC1	CC2	CC3	Read & Write	NVM NFC
4	Data0	Data1	Data2	Data3	Read & Write	NVM NFC
5	Data4	Data5	Data6	Data7		
...		
63	Data236	Data237	Data238	Data239		
64 to 79	EPC memory mapping (see tables below)				see below	NVM EPC
80	Dynamic Lock0	Dynamic Lock1	Dynamic Lock Lock	RFU	Read & Write 1's	NVM NFC
81	RFU	RFU	RFU	IC Config 0	Read & Write	NVM NFC
82	IC Config 1 Config Locks	IC Config 1 Config Locks	RFU	RFU		
83	IC Config 2	RFU	RFU	RFU		
84	IC Config 3 EPC Privacy Select	RFU	IC Config 3 EPC Privacy Set	RFU	Read 0's & Write	NVM EPC
85	4 Byte Password0	4 Byte Password1	4 Byte Password2	4 Byte Password3	Read 0's & Write	NVM NFC
86	PACK0	PACK1	2 Byte Password0	2 Byte Password1		
87	32 Byte Signature0	32 Byte Signature1	32 Byte Signature2	32 Byte Signature3	Read & Write	NVM NFC
...		
94	32 Byte Signature28	32 Byte Signature29	32 Byte Signature30	32 Byte Signature31		
95	NFC Sharing Read Lock0	NFC Sharing Read Lock1	NFC Sharing Read Lock2	NFC Sharing Read Lock3	Read & Write	NVM NFC
96	NFC Sharing Write Lock0	NFC Sharing Write Lock1	NFC Sharing Write Lock2	NFC Sharing Write Lock3		
97	EPC Sharing Read Lock0	EPC Sharing Read Lock1	RFU	RFU		
98	EPC Sharing Write Lock0	EPC Sharing Write Lock1	RFU	RFU		

The NFC interface access to blocks 64 to 79 (EPC mapped memory) is controlled first by the NFC password protection and locks used for the NFC User memory and subsequently by the EPC locks used by the EPC interface unless stated otherwise in this document.

The NFC interface has read/write access to the EPC mapped memory but only as permitted by Gen2V2config word byte0.

Block 64 is read/write from the NFC interface when Kill Pwd [1:0] = 00₂ or 01₂ and is both read and write protected from the NFC interface when Kill Pwd [1:0] = 10₂ or 11₂.

Block 65 is read/write from the NFC interface when Access Pwd [1:0] = 00₂ or 01₂ and is both read and write protected from the NFC interface when Access Pwd [1:0] = 10₂ or 11₂.

Blocks 66 to 68 can always be read but are always write protected from the NFC interface.

Blocks 69 to 78 can always be read but are write protected from the NFC interface when EPC [1:0] = 10₂ or 11₂.

Blocks 2, 3, 79, 80, 83, 84 are anti-tearing mechanism protected.

**5.1. EPC MEMORY MAPPING FOR SMALL EPC**

NFC Block Address (decimal)	EPC MEMORY BANK	Bytes Within a Block				Access Type (unless password protected or locked)	Memory Type
		MSB Byte 0	Byte 1	Byte 2	LSB Byte 3		
64	RESERVED	Word 0 : Kill Password MSW		Word 1 : Kill Password LSW		Read & Write	NVM EPC
65		Word 2 : Access Password MSW		Word 3 : Access Password LSW			
66	TID	Word 0		Word 1		Read Only	ROM / NVM EPC
67		Word 2		Word 3			
68		Word 4		Word 5			
69	EPC/UII	Word 0 : StoredCRC		Word 1 : StoredPC		Read & Write	Computed / NVM EPC
70		Word 2 : SGTIN-96 MSW		Word 3			
71		Word 4		Word 5			
72		Word 6		Word 7 : SGTIN-96 LSW			
73		Word 8		Word 9			
74	USER	Word 0		Word 1		Read & Write	NVM EPC
75		Word 2		Word 3			
76		Word 4		Word 5			
77		Word 6		Word 7			
78		Word 8		Word 9			
79	N/A	Gen2V2 Configuration (see Gen2V2config Word)				Read & Write 1's	Computed / NVM EPC

NOTE: EPC Memory Bank example for SGTIN-96 encoding.

5.2. EPC MEMORY MAPPING FOR LARGE EPC

NFC Block Address (decimal)	EPC MEMORY BANK	Bytes Within a Block				Access Type (unless password protected or locked)	Memory Type
		MSB Byte 0	Byte 1	Byte 2	LSB Byte 3		
64	RESERVED	Word 0 : Kill Password MSW		Word 1 : Kill Password LSW		Read & Write	NVM EPC
65		Word 2 : Access Password MSW		Word 3 : Access Password LSW			
66	TID	Word 0		Word 1		Read Only	ROM / NVM EPC
67		Word 2		Word 3			
68		Word 4		Word 5			
69	EPC/UII	Word 0 : StoredCRC		Word 1 : StoredPC		Read & Write	Computed / NVM EPC
70		Word 2 : SGTIN-198 MSW		Word 3			
71		Word 4		Word 5			
72		Word 6		Word 7			
73		Word 8		Word 9			
74		Word 10		Word 11			
75		Word 12		Word 13			
76		Word 14 : SGTIN-198 LSW		Word 15			
77		USER	Word 0		Word 1		
78	Word 2		Word 3				
79	N/A	Gen2V2 Configuration (see Gen2V2config Word)				Read & Write 1's	Computed / NVM EPC

NOTE: EPC Memory Bank example for SGTIN-198 encoding.



5.3. MEMORY CONTENT AT DELIVERY

At chip delivery, all memory is programmed to 00h if not stated differently.

The Capability Container (CC) is programmed during the IC production according to NFC Forum

Type 2 Tag specification as follows:

Capability Container (CC)		Description
Field name	Value at delivery (Hex)	
CC0	E1h	E1h indicates that NDEF data is present inside the tag
CC1	10h	10h indicates support for version 1.0 of the [NFC_T2TOP] specification
CC2	1Eh	indicates 240 bytes of memory size assigned to the data area (240/8)
CC3	00h	indicates read and write access granted to User's memory and CC area without any security

At chip delivery, the byte PWD_PROT_EPC+PWD_PROT_ADDR value is programmed to FFh.

UID is programmed and write protected before delivery.

UID is defined as follows:

UID Number		Description
Field name [bits range]	Value at delivery (Hex)	
UID0	16h	IC manufacturer Code
UID1 & UID2	16h	6 bit IC ID 16h corresponds to em echo
	001h	10 bit Customer ID (standard version)
BCC0	calculated	in accordance with ISO/IEC 14443-3 defined as $CT \oplus UID0 \oplus UID1 \oplus UID2$ CT – Cascade Tag Type A (= 88h)
UID3 & UID4 & UID5 & UID6	unique	32-bit Unique Serial Number (same as in EPC TID)
BCC1	calculated	in accordance with ISO/IEC 14443-3 defined as $UID3 \oplus UID4 \oplus UID5 \oplus UID6$

Lock Control TLV		Description
Field name [bits range]	Value at delivery (Hex)	
Data0	01h	T Field
Data1	03h	L Field
Data2	A0h	V Field defining Lock Position
Data3	0Ch	V Field defining Lock Size
Data4	45h	V Field defining Lock Page Control

Empty NDEF message TLV		Description
Field name [bits range]	Value at delivery (Hex)	
Data5	03h	T Field
Data6	00h	L Field

Terminator TLV		Description
Field name [bits range]	Value at delivery (Hex)	
Data7	FEh	T Field



5.4. DETAILED MEMORY DESCRIPTION

5.4.1. STATIC LOCK BYTES

See [NFC_T2TOP] for bits functionality explanation.

The purpose of Static Lock bytes is to allow locking of blocks 2 to 15 against writing.

The setting of static lock bits is irreversible: if the appropriate bit of the lock bytes is set, it cannot be reset to '0'.

If all bits are set to 0 then the Capability Container and User memory (Blocks 4 to 15) of the tag can be read and written.

If all bits are set to 1 then the Capability Container and User memory (Blocks 4 to 15) of the tag can only be read.

The Static Lock bytes have no effect on the EPC interface. The corresponding NFC_WLOCK bits in the NFC sharing "write" lock bytes must be set = 1 to prevent the EPC interface from writing the User data values. The NFC_WLOCK_CC bit in the NFC sharing "write" lock bytes must be set = 1 to prevent the EPC interface from writing the Capability Container value.

It is also possible to lock individual blocks against writing as defined below:

Static_Lock0 Byte		Description
Field name	Value at delivery (Hex)	
bit 7	0	if bit is zero then block 7 is writable otherwise it is read-only protected
bit 6	0	if bit is zero then block 6 is writable otherwise it is read-only protected
bit 5	0	if bit is zero then block 5 is writable otherwise it is read-only protected
bit 4	0	if bit is zero then block 4 is writable otherwise it is read-only protected
bit 3	0	if bit is zero then block CC is writable otherwise it is read-only protected
bit 2	0	if bit is set then Static_Lock1[7:2] can no longer be changed
bit 1	0	if bit is set then Static_Lock1[1:0] and Static_Lock0[7:4] can no longer be changed
bit 0	0	if bit is set then Static_Lock0[3] can no longer be changed

Static_Lock1 Byte		Description
Field name	Value at delivery (Hex)	
bit 7	0	if bit is zero then block 15 is writable otherwise it is read-only protected
bit 6	0	if bit is zero then block 14 is writable otherwise it is read-only protected
bit 5	0	if bit is zero then block 13 is writable otherwise it is read-only protected
bit 4	0	if bit is zero then block 12 is writable otherwise it is read-only protected
bit 3	0	if bit is zero then block 11 is writable otherwise it is read-only protected
bit 2	0	if bit is zero then block 10 is writable otherwise it is read-only protected
bit 1	0	if bit is zero then block 9 is writable otherwise it is read-only protected
bit 0	0	if bit is zero then block 8 is writable otherwise it is read-only protected



5.4.2. CAPABILITY CONTAINER (CC)

See [NFC_T2TOP] for bits functionality explanation.

5.4.3. NFC USER MEMORY

The memory area available from block 4 to 63 is dedicated for NFC data. The protection by Static Lock bytes or Dynamic Lock bytes may be applied to write protect the NFC data from writing via the NFC interface.

The corresponding NFC_WLOCK bits in the NFC sharing “write” lock bytes must be set = 1 to prevent the EPC interface from writing the User data values.

5.4.4. EPC MAPPED MEMORY

The memory area available from block 64 to 79 is dedicated for the mapping of EPC memory. The same memory protection rules can be applied as for NFC User memory.

5.4.5. GEN2V2CONFIG WORD

The NFC interface may only write this word in SECURE state with PWD_LIM ≠ 0.

BYTE 0

MSB							LSB
Kill Pwd 1	Kill Pwd 0	Access Pwd 1	Access Pwd 0	EPC 1	EPC 0	User 1	User 0
bit 7	bit 6	bit 5	bit 4	bit 3	bit 2	bit 1	bit 0

See [EPC_Gen2v2] LOCK command for bits functionality explanation.

Setting of bits in Byte 0 is irreversible by NFC interface.

If the appropriate pair of bits is not “00”, it cannot be changed.

BYTE 1

MSB							LSB
Killed State	0	0	0	0	0	0	0
bit 7	bit 6	bit 5	bit 4	bit 3	bit 2	bit 1	bit 0

See [EPC_Gen2v2] Killed State for bits functionality explanation.

Byte 1 is READ ONLY.

BYTE 2

MSB							LSB
NR	H	U	Hide EPC	Hide TID 1	Hide TID 0	Hide User	Reduce Range
bit 7	bit 6	bit 5	bit 4	bit 3	bit 2	bit 1	bit 0

See [EPC_Gen2v2] XPC_W1 Word and UNTRACEABLE command for bits functionality explanation.

**BYTE 3****IF SHORT EPC MEMORY**

MSB							LSB
UHF Power	Block 0 Locked	Block 1 Locked	Block 2 Locked	Block 3 Locked	Block 4 Locked	0	0
bit 7	bit 6	bit 5	bit 4	bit 3	bit 2	bit 1	bit 0

IF LARGE EPC MEMORY

MSB							LSB
UHF Power	Block 0 Locked	Block 1 Locked	0	0	0	0	0
bit 7	bit 6	bit 5	bit 4	bit 3	bit 2	bit 1	bit 0

UHF_Power – can be used to indicate if the UHF rectifier is providing power when HF field is not present

‘0’ – the indicator is reset when the chip goes to power down (powered neither from EPC nor NFC)

‘1’ – the indicator is set when Gen2V2config word is read by READ command

See [EPC_Gen2v2] BLOCKPERMALOCK command for other bits functionality explanation.

Setting of bits in Byte 3 is irreversible by NFC interface: if the appropriate bit is set, it cannot be changed back to 0.

**5.4.6. DYNAMIC LOCK BYTES**

See [NFC_T2TOP] for bits functionality explanation.

Setting of dynamic lock bits is irreversible: if the appropriate bit is set, it cannot be changed back to 0.

The Dynamic Lock bytes have no effect on the EPC interface. The corresponding NFC_WLOCK bits in the NFC sharing “write” lock bytes must be set = 1 to prevent the EPC interface from writing the User data values.

BYTE 0

MSB							LSB
LOCK BLOCK 44-47	LOCK BLOCK 40-43	LOCK BLOCK 36-39	LOCK BLOCK 32-35	LOCK BLOCK 28-31	LOCK BLOCK 24-27	LOCK BLOCK 20-23	LOCK BLOCK 16-19
bit 7	bit 6	bit 5	bit 4	bit 3	bit 2	bit 1	bit 0

LOCK_BLOCK – if the bit is set then the appropriate memory block is write protected

BYTE 1

MSB							LSB
LOCK BLOCK 76-79	LOCK BLOCK 72-75	LOCK BLOCK 68-71	LOCK BLOCK 64-67	LOCK BLOCK 60-63	LOCK BLOCK 56-59	LOCK BLOCK 52-55	LOCK BLOCK 48-51
bit 7	bit 6	bit 5	bit 4	bit 3	bit 2	bit 1	bit 0

LOCK_BLOCK – if the bit is set then the appropriate memory block is write protected

BYTE 2

MSB							LSB
BL 72-79	BL 64-71	BL 56-63	BL 48-55	BL 40-47	BL 32-39	BL 24-31	BL 16-23
bit 7	bit 6	bit 5	bit 4	bit 3	bit 2	bit 1	bit 0

BL – if the bit is set then the appropriate memory LOCK_BLOCK bit is protected against update

BYTE 3 – RFU



5.4.7. IC CONFIGURATION 0 WORD

When it is changed then the new value is accepted after Power-Up.

The ICCFG_LOCK bit in IC Configuration 1 word has no effect on the EPC interface. The NFC_WLOCK_81 bit in the NFC sharing “write” lock bytes must be set = 1 to prevent the EPC interface from writing the IC Configuration 0 word value.

BYTE 0, 1, 2 – RFU

BYTE 3

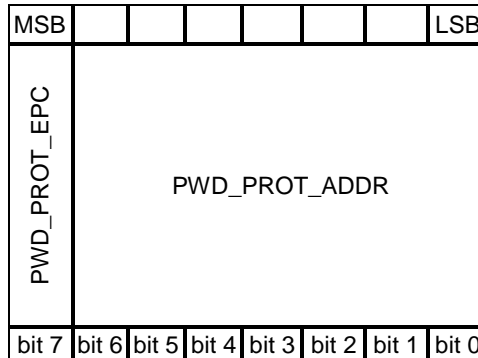

PWD_PROT_EPC – defines if the EPC mapped memory is protected by PWD_PROT_ADDR

‘0’ – protected by PWD_PROT_ADDR

‘1’ – no PWD_PROT_ADDR protection applied **StartAddr, AddrBlock** parameters of read/write command has to address EPCmapped memory

PWD_PROT_ADDR – defines the start block address from which the memory protection is enabled when not in SECURE state

Valid address range for PWD_PROT_ADDR byte is from 00h to 7Fh.

The memory protection type is defined by PROT_TYPE bit.

Password protection has no effect on the EPC interface. The corresponding NFC_RLOCK bits and NFC_WLOCK bits in the NFC sharing “read” lock bytes and “write” lock bytes must be set = 1 to prevent the EPC interface from reading and writing the User data values.



5.4.8. IC CONFIGURATION 1 WORD

When it is changed then the new value is accepted after Power-Up.

The ICCFG_LOCK bit in IC Configuration 1 word has no effect on the EPC interface. The NFC_WLOCK_82 bit in the NFC sharing “write” lock bytes must be set = 1 to prevent the EPC interface from writing the IC Configuration 1 word value.

BYTE 0

MSB							LSB
PROT_TYPE	ICCFG_LOCK	ICCFG3_LOCK	ACCESS_CNT_EN	ACCESS_PROT_TYPE	PWD_LIM		
bit 7	bit 6	bit 5	bit 4	bit 3	bit 2	bit 1	bit 0

PROT_TYPE – the memory protection type related to PWD_PROT_ADDR

‘0’ – write access is protected when not in SECURE states

‘1’ – read & write access is protected when not in SECURE states

ICCFG_LOCK

‘0’ – IC Configuration 0, 1, and 2 words unprotected

‘1’ – IC Configuration 0, 1, and 2 words permanently protected against update

ICCFG3_LOCK

‘0’ – IC Configuration 3 word unprotected

‘1’ – IC Configuration 3 word permanently protected against update

ACCESS_CNT_EN

‘0’ – ACCESS counter disabled (not incremented during the first read command)

‘1’ – ACCESS counter enabled

ACCESS_PROT_TYPE – defines readability of ACCESS counter (READ_COUNTER)

‘0’ – ACCESS counter readable in ACTIVE or SECURE states

‘1’ – ACCESS counter readable only in SECURE state

PWD_LIM

‘000’ – unsuccessful LOGIN counter disabled

‘001’-‘111’ – defines maximum number of unsuccessful LOGINS

BYTE 1

MSB							LSB
SIG_LOCK	0	0	0	0	0	0	0
bit 7	bit 6	bit 5	bit 4	bit 3	bit 2	bit 1	bit 0

SIG_LOC

‘0’ – 32 Byte Signature memory is unprotected

‘1’ – 32 Byte Signature memory is permanently protected against update from both NFC and EPC.

Setting of SIG_LOCK bit is irreversible from both NFC and EPC interface: if the appropriate bit is set, it cannot be changed back to 0.

BYTE 2, 3 – RFU

5.4.9. IC CONFIGURATION 2 WORD

When it is changed then the new value is accepted after Power-Up.



The ICCFG_LOCK bit in IC Configuration 1 word has no effect on the EPC interface. The NFC_WLOCK_83 bit in the NFC sharing “write” lock bytes must be set = 1 to prevent the EPC interface from writing the IC Configuration 2 word value.

BYTE 0

MSB							LSB
PRIVACY_EN	0	0	0	0	0	0	0
bit 7	bit 6	bit 5	bit 4	bit 3	bit 2	bit 1	bit 0

PRIVACY_EN – selects in which state the NFC interface will go after INITIALIZATION; this bit can be changed also by EN_DIS_PRIVACY custom command.

‘0’ – to IDLE NFC state

‘1’ – to PRIVACY state (answering only to LOGIN with correct 2 Byte Password)

BYTE 1, 2, 3 – RFU

**5.4.10. IC CONFIGURATION 3 WORD**

This word is WRITE ONLY for the NFC interface and is as defined below.

The NFC interface may only write this word in SECURE state with PWD_LIM ≠ 0.

The ICCFG3_LOCK bit in IC Configuration 1 word is the only lock bit that prevents the NFC interface from writing to the IC Configuration 3 word which updates either the StoredPC word or the Gen2V2config word in EPC memory.

This word is read and write protected for the EPC interface and error code is replied.

BYTE 0

MSB							LSB
0	0	0	0	0	0	0	EPC Privacy
bit 7	bit 6	bit 5	bit 4	bit 3	bit 2	bit 1	bit 0

See section on EPC Privacy Features.

EPC Privacy – selects which of the EPC privacy settings are selected for write operations.

'0' – EPC privacy settings in the Gen2V2config word

'1' – EPC privacy settings in the StoredPC word

BYTE 1 – RFU**BYTE 2****EPC PRIVACY = 0**

MSB							LSB
0	0	U	Hide EPC	Hide TID 1	Hide TID 0	Hide User	Reduce Range
bit 7	bit 6	bit 5	bit 4	bit 3	bit 2	bit 1	bit 0

EPC PRIVACY = 1

MSB							LSB
0	StoredPC L 3	StoredPC L 2	StoredPC L 1	StoredPC L 0	0	0	0
bit 7	bit 6	bit 5	bit 4	bit 3	bit 2	bit 1	bit 0

See [EPC_Gen2v2] StoredPC Word, XPC_W1 Word and UNTRACEABLE command for all other bits functionality explanation.

BYTE 3 – RFU



5.4.11. 4 BYTE PASSWORD

The 4 Byte Password is the data which is compared to password as part of the LOGIN command to enter SECURE state from ACTIVE state.

The 4 Byte Password is permanently read protected (zeros are read) via the NFC interface.

The NFC_RLOCK_85 bit in the NFC sharing “read” lock bytes must be set = 1 to prevent the EPC interface from reading the 4 Byte Password value. The NFC_WLOCK_85 bit in the NFC sharing “write” lock bytes must be set = 1 to prevent the EPC interface from writing the 4 Byte Password value.

5.4.12. PACK

The PACK is the 16-bit data which is compared to password as part of the LOGIN command to enter IDLE state from PRIVACY state and the PACK is sent as response to LOGIN command.

The PACK is permanently read protected (zeros are read) via the NFC interface.

The NFC_RLOCK_86 bit in the NFC sharing “read” lock bytes must be set = 1 to prevent the EPC interface from reading the PACK value. The NFC_WLOCK_86 bit in the NFC sharing “write” lock bytes must be set = 1 to prevent the EPC interface from writing the PACK value.

5.4.13. 2 BYTE PASSWORD

The 2 Byte Password is the data which is compared to password as part of the LOGIN command to enter IDLE state from PRIVACY state.

The 2 Byte Password is permanently read protected (zeros are read) via the NFC interface.

The NFC_RLOCK_86 bit in the NFC sharing “read” lock bytes must be set = 1 to prevent the EPC interface from reading the 2 Byte Password value. The NFC_WLOCK_86 bit in the NFC sharing “write” lock bytes must be set = 1 to prevent the EPC interface from writing the 2 Byte Password value.

5.4.14. 32 BYTE SIGNATURE

The 32 Byte Signature is a 256-bit memory for a digital signature or for general use.

The NFC_RLOCK_32B bit in the NFC sharing “read” lock bytes must be set = 1 to prevent the EPC interface from reading the Signature value. The NFC_WLOCK_32B bit in the NFC sharing “write” lock bytes must be set = 1 to prevent the EPC interface from writing the Signature value.

**5.4.15. NFC SHARING “READ” LOCK BYTES**

The following bytes control sharing of NFC memory reading via the EPC interface.

NFC_RLOCK – if the bit is set then the appropriate memory block(s) is/are protected against reading via the EPC interface.

BYTE 0

MSB							LSB
NFC_RLOCK_16_19	NFC_RLOCK_12_15	NFC_RLOCK_8_11	NFC_RLOCK_4_7	HF_RLOCK_CC = 0	HF_RLOCK_2 = 0	HF_RLOCK_1 = 0	HF_RLOCK_0 = 0
bit 7	bit 6	bit 5	bit 4	bit 3	bit 2	bit 1	bit 0

BYTE 1

MSB							LSB
NFC_RLOCK_48_51	NFC_RLOCK_44_47	NFC_RLOCK_40_43	NFC_RLOCK_36_39	NFC_RLOCK_32_35	NFC_RLOCK_28_31	NFC_RLOCK_24_27	NFC_RLOCK_20_23
bit 7	bit 6	bit 5	bit 4	bit 3	bit 2	bit 1	bit 0

BYTE 2

MSB							LSB
NFC_RLOCK_84 = 1	NFC_RLOCK_83	NFC_RLOCK_82	NFC_RLOCK_81	NFC_RLOCK_80	NFC_RLOCK_60_63	NFC_RLOCK_56_59	NFC_RLOCK_52_55
bit 7	bit 6	bit 5	bit 4	bit 3	bit 2	bit 1	bit 0

BYTE 3

MSB							LSB
HF_RLOCK_98	HF_RLOCK_97	HF_RLOCK_96	HF_RLOCK_95	NFC_RLOCK_32B	0	NFC_RLOCK_86 = 1	NFC_RLOCK_85 = 1
bit 7	bit 6	bit 5	bit 4	bit 3	bit 2	bit 1	bit 0

**5.4.16. NFC SHARING “WRITE” LOCK BYTES**

The following bytes control sharing of NFC memory writing via the EPC interface.

NFC_WLOCK – if the bit is set then the appropriate memory block(s) is/are protected against writing via the EPC interface.

BYTE 0

MSB							LSB
NFC_WLOCK_16_19	NFC_WLOCK_12_15	NFC_WLOCK_8_11	NFC_WLOCK_4_7	NFC_WLOCK_CC	NFC_WLOCK_2	HF_RLOCK_1 = 1	HF_RLOCK_0 = 1
bit 7	bit 6	bit 5	bit 4	bit 3	bit 2	bit 1	bit 0

BYTE 1

MSB							LSB
NFC_WLOCK_48_51	NFC_WLOCK_44_47	NFC_WLOCK_40_43	NFC_WLOCK_36_39	NFC_WLOCK_32_35	NFC_WLOCK_28_31	NFC_WLOCK_24_27	NFC_WLOCK_20_23
bit 7	bit 6	bit 5	bit 4	bit 3	bit 2	bit 1	bit 0

BYTE 2

MSB							LSB
NFC_WLOCK_84 = 1	NFC_WLOCK_83	NFC_WLOCK_82	NFC_WLOCK_81	NFC_WLOCK_80	NFC_WLOCK_60_63	NFC_WLOCK_56_59	NFC_WLOCK_52_55
bit 7	bit 6	bit 5	bit 4	bit 3	bit 2	bit 1	bit 0

BYTE 3

MSB							LSB
NFC_WLOCK_98	NFC_WLOCK_97	NFC_WLOCK_96	NFC_WLOCK_95	NFC_WLOCK_32B	0	NFC_WLOCK_86	NFC_WLOCK_85
bit 7	bit 6	bit 5	bit 4	bit 3	bit 2	bit 1	bit 0

5.4.17. EPC SHARING “READ” LOCK BYTES

The following bytes control sharing of EPC memory reading via the NFC interface.



EPC_RLOCK – if the bit is set then the appropriate memory block(s) is/are protected against reading via the NFC interface. Zeros are read from the block when the appropriate bit is set.

BYTE 0

MSB							LSB
UHF_RLOCK_71	UHF_RLOCK_70	UHF_RLOCK_69	UHF_RLOCK_68	UHF_RLOCK_67	UHF_RLOCK_66	UHF_RLOCK_65	UHF_RLOCK_64
bit 7	bit 6	bit 5	bit 4	bit 3	bit 2	bit 1	bit 0

BYTE 1

MSB							LSB
UHF_RLOCK_79	UHF_RLOCK_78	UHF_RLOCK_77	UHF_RLOCK_76	UHF_RLOCK_75	UHF_RLOCK_74	UHF_RLOCK_73	UHF_RLOCK_72
bit 7	bit 6	bit 5	bit 4	bit 3	bit 2	bit 1	bit 0

BYTE 2, 3 – RFU

**5.4.18. EPC SHARING “WRITE” LOCK BYTES**

The following bytes control sharing of EPC memory writing via the NFC interface.

EPC_WLOCK – if the bit is set then the appropriate memory block(s) is/are protected against writing via the NFC interface.

BYTE 0

MSB							LSB
UHF_WLOCK_71	UHF_WLOCK_70	UHF_WLOCK_69	UHF_WLOCK_68 = 1	UHF_WLOCK_67 = 1	UHF_WLOCK_66 = 1	UHF_WLOCK_65	UHF_WLOCK_64
bit 7	bit 6	bit 5	bit 4	bit 3	bit 2	bit 1	bit 0

BYTE 1

MSB							LSB
UHF_WLOCK_79	UHF_WLOCK_78	UHF_WLOCK_77	UHF_WLOCK_76	UHF_WLOCK_75	UHF_WLOCK_74	UHF_WLOCK_73	UHF_WLOCK_72
bit 7	bit 6	bit 5	bit 4	bit 3	bit 2	bit 1	bit 0

BYTE 2, 3 – RFU



6. NFC COMMAND SET

6.1. SUMMARY OF COMMANDS

Command	Command code	ISO/IEC 14443 Type A	NFC Forum Type 2
Request A	'26h'	REQA	SENS_REQ
Wake-up A	'52h'	WUPA	ALL_REQ
Anti-collision Cascade Level 1	'93h 20h'	Anti-collision CL1	SDD_REQ CL1
Select Cascade Level1	'93h 70h'	Select CL1	SEL_REQ CL1
Anti-collision Cascade Level 2	'95h 20h'	Anti-collision CL2	SDD_REQ CL2
Select Cascade Level2	'95h 70h'	Select CL2	SEL_REQ CL2
Halt A	'50h 00h'	HLTA	SLP_REQ
READ	'30h'	-	READ
WRITE	'A2h'	-	WRITE
SECTOR_SELECT	'C2h'	-	SECTOR SELECT
READ_COUNTER	'39h'	-	-
EN_DIS_PRIVACY	'3Fh'	-	-
LOGIN	'1Bh'	-	-

6.2. COMMANDS AND STATES

The table below shows which commands are supported in which states. If a command is not supported then em|echo doesn't respond.

Command	PRIVACY	IDLE	HALT	READY	ACTIVE	SECURE
Request A		■				
Wake-up A		■	■			
Anti-collision Cascade Level 1				■		
Select Cascade Level1				■		
Anti-collision Cascade Level 2				■		
Select Cascade Level2				■		
Halt A					■	■
READ				■ 1)	■	■
WRITE					■	■
SECTOR_SELECT					■	■
READ_COUNTER					■	■
EN_DIS_PRIVACY						■
LOGIN	■ 2)				■ 3)	■
■ the command is supported in the appropriate state						

Note 1: only reading from address 0 is supported in READY state

Note 2: PACK + 2 Byte Password LOGIN

Note 3: 4 Byte password LOGIN

If command is not supported in the appropriate state then the command is not executed and PICC stays quiet and there is transition to IDLE or HALT state as explained in chapter "State diagram".



6.2.1. TIMING

The communication between PCD and em|echo is composed of PCD command and em|echo answer. The communication is always initiated by PCD.

Any PCD command begins with Start of communication symbol and finishes with End of communication symbol according to [ISO_14443_3].

6.2.2. ISO14443-3 COMMANDS

See [ISO_14443_3].

6.2.3. ACK AND NACK RESPONSES

4 bits are used as a response if no data are return on a command.

- "1010" - ACK
- "0000" - NACK if wrong command argument(s)
- "0001" - NACK if parity or CRC error
- "0100" - NACK if addressed NVM is currently used by the second interface
- "0101" - NACK if writing to NVM is forbidden (a power is low)
{Bits order – 3210}

See also [NFC_T2TOP].



6.3. NFC COMMANDS

READ

The READ command is compliant to [NFC_DigitalSpec]

The command format is as below.

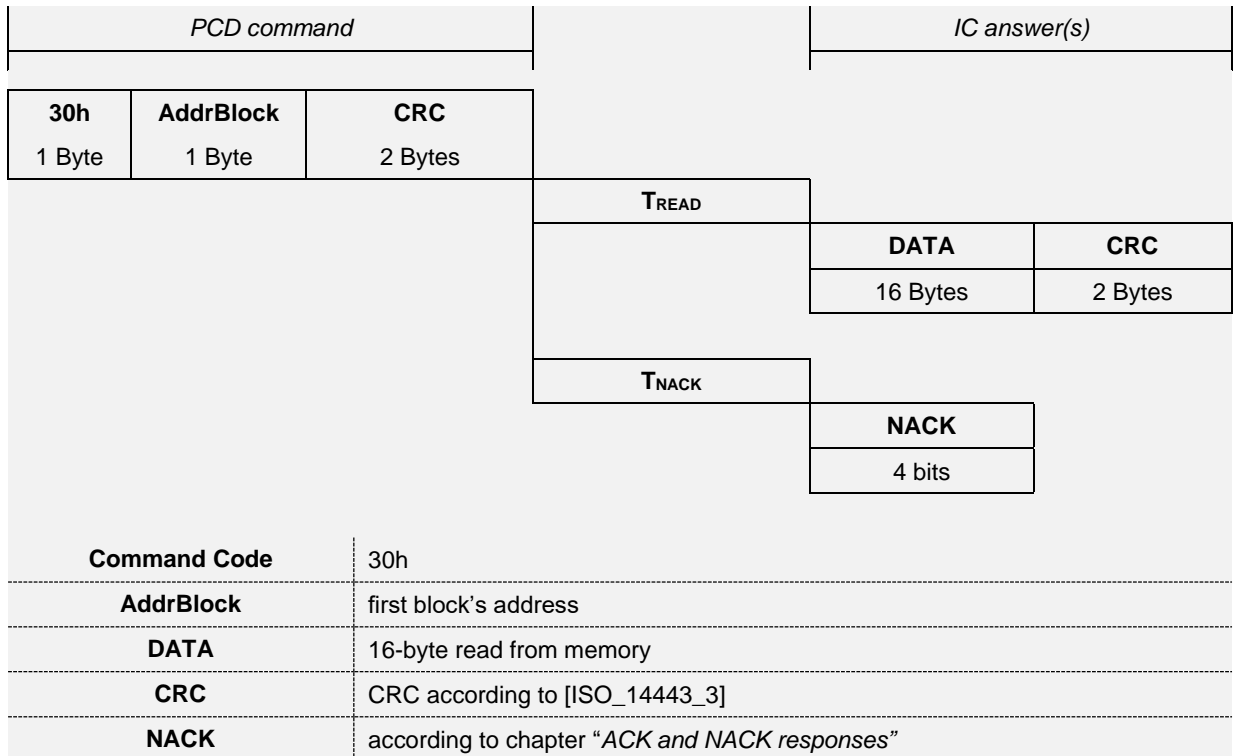

For a command descriptions see also [NFC_T2TOP].

IF PROT_TYPE = '1'

In ACTIVE state

If **AddrBlock** is equal or higher than PWD_PROT_ADDR address then there is NACK answer..

There is a roll-over mechanism implemented. It allows continuing reading from address 00h when the (PWD_PROT_ADDR-1) address is reached.

In SECURE state

can be addressed the whole available memory.

IF PROT_TYPE = '0'

PWD_PROT_ADDR is not cared and the whole memory is available.



WRITE

The WRITE command is compliant to [NFC_DigitalSpec]

The command format is as below.

PCD command				IC answer(s)	
A2h 1 Byte	AddrBlock 1 Byte	DATA 4 Bytes	CRC 2 Bytes		
				T_{WRITE}	
					ACK 4 bits
				T_{NACK}	
					NACK 4 bits
Command Code	A2h				
AddrBlock	the address of a block to be written				
DATA	4-byte data				
CRC	CRC according to [ISO_14443_3]				
ACK	according to chapter "ACK and NACK responses"				
NACK	according to chapter "ACK and NACK responses"				

For a command descriptions see also [NFC_T2TOP].

In ACTIVE state

If **AddrBlock** is equal or higher than PWD_PROT_ADDR address then there is NACK answer.

In SECURE state

can be addressed the whole available memory.



SECTOR_SELECT

The SECTOR_SELECT command is compliant to [NFC_DigitalSpec]

The command format is as below.

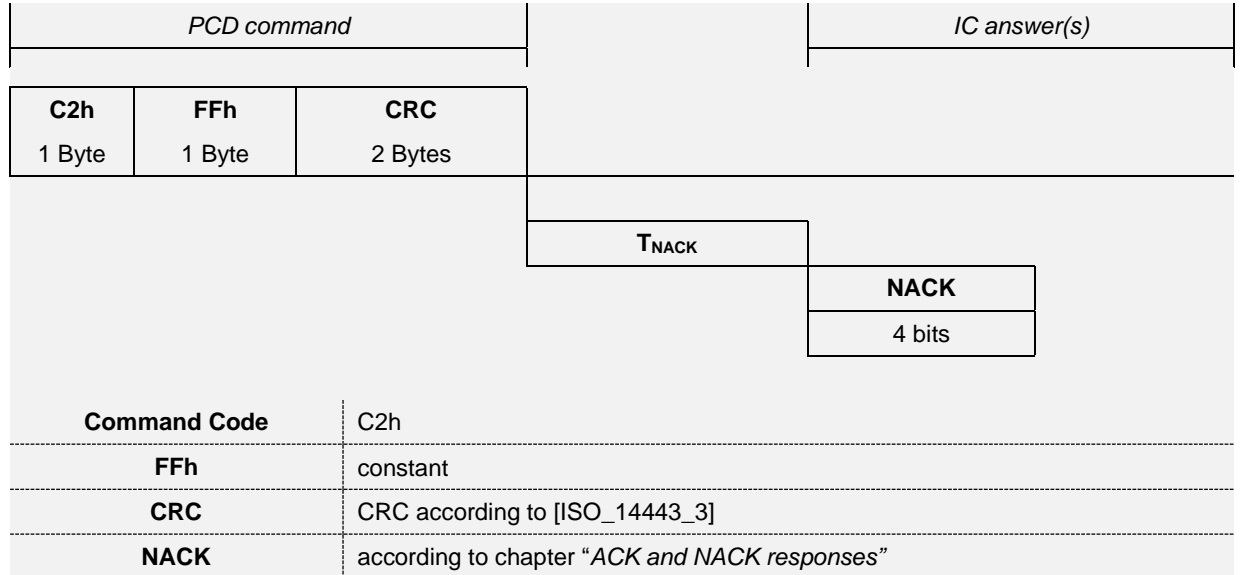

For a command descriptions see also [NFC_T2TOP].



6.3.1. PROPRIETARY COMMANDS

READ_COUNTER

This command returns as an answer a content of 24-bit counter. The AddrCnt is sent as part of the command by PCD.

The command format is as below.

PCD command			IC answer(s)	
39h 1 Byte	AddrCnt 1 Byte	CRC 2 Bytes		
			T_{READ_COUNTER}	
				DATA 3 Bytes
				CRC 2 Bytes
			T_{NACK}	
				NACK 4 bits
Command Code		39h		
AddrCnt		the address of a counter (em echo offers just one counter ; any value in this field is allowed)		
DATA		3-byte counter content		
CRC		CRC according to [ISO_14443_3]		
NACK		according to chapter "ACK and NACK responses"		



EN_DIS_PRIVACY

This command enables or disables PRIVACY feature.

The command format is as below.

<i>PCD command</i>					<i>IC answer(s)</i>
3Fh	Action	RFU	CRC		
1 Byte	1 Byte	4 Bytes	2 Bytes		
				T_{EN_DIS_PRIVACY}	
					ACK
					4 bits
				T_{NACK}	
					NACK
					4 bits
Command Code		3Fh			
Action		action selector 00h - disable PRIVACY 01h - enable PRIVACY 02h – FFh - RFU (NACK is returned as the response)			
RFU		4 dummy bytes			
CRC		CRC according to [ISO_14443_3]			
ACK		according to chapter “ACK and NACK responses”			
NACK		according to chapter “ACK and NACK responses”			



LOGIN

This command transitions the em|echo from PRIVACY to IDLE state or from ACTIVE to SECURE state after successful password authentication.

The command format is as below.

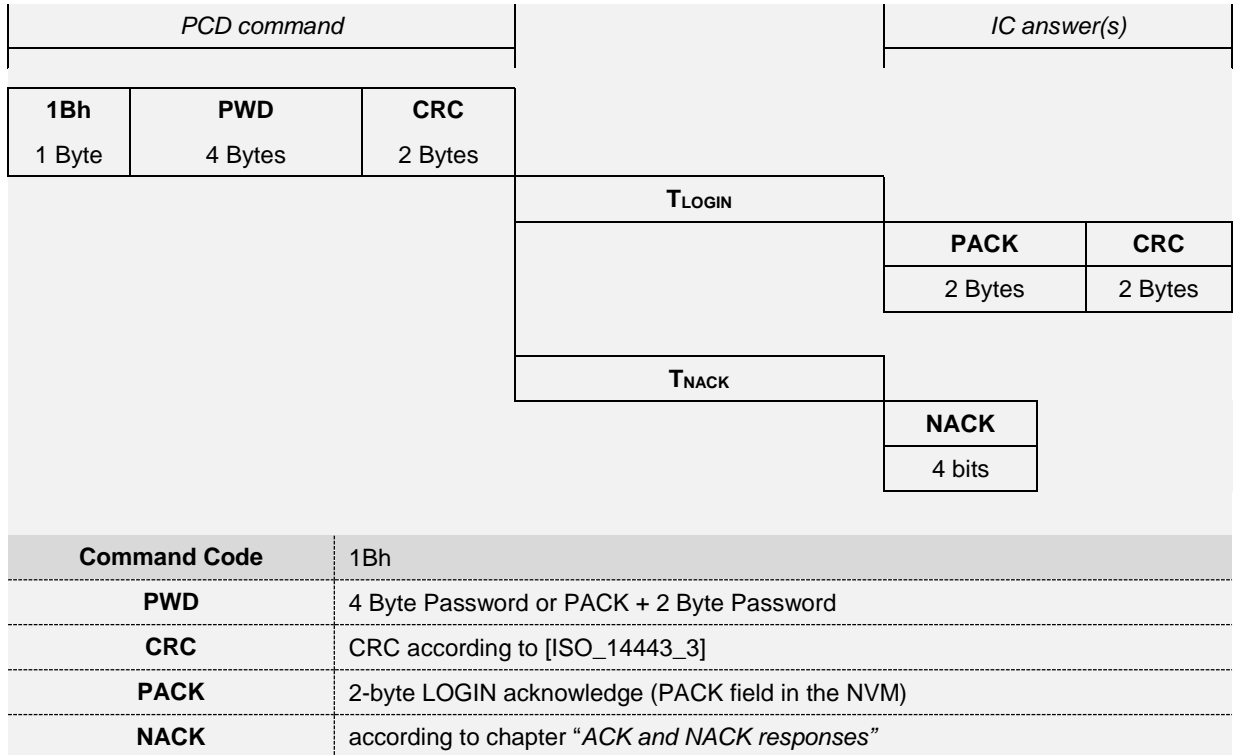

PRIVACY TO IDLE

If PWD field is equal to PACK + 2 Byte Password in the memory then the authentication is successful and the em|echo changes its state from PRIVACY to IDLE state. Then PACK + CRC are returned as successful LOGIN acknowledge. NACK is never replied in PRIVACY state.

ACTIVE TO SECURE

If PWD field is equal to 4 Byte Password in the memory then the authentication is successful and the em|echo changes its state from ACTIVE to SECURE state. Then PACK + CRC are returned as successful LOGIN acknowledge. NACK is not replied if wrong PWD.



7. EPC FUNCTIONAL DESCRIPTION

7.1. EPC MEMORY ORGANIZATION

The EPC Gen2 V2 memory is available in two configurations to support either small or large EPC encodings.

The small EPC memory configuration provides 128 bits for encoding and 160 bits of USER memory. This supports the most commonly used tag encodings (e.g. SGTIN-96) as well as RFID based EAS solutions that utilize USER memory.

The large EPC memory configuration provides 224 bits for encoding and 64 bits of USER memory. This supports the larger tag encodings (e.g. SGTIN-198) as well as RFID based EAS solutions that utilize USER memory.

Both EPC memory configurations include the NFC memory as part of the USER memory.

The following memory maps are as seen in the application:

**7.2. EPC GEN2 V2 - SMALL EPC MEMORY MAP**

Memory Bank	Word Address (decimal)	Content	Access Type (unless password protected or locked)	Memory Type
00 ₂ : RESERVED	0	Kill Password [31:16]	Read & Write	NVM EPC
	1	Kill Password [15:0]		
	2	Access Password [31:16]		
	3	Access Password [15:0]		
01 ₂ : EPC	0	StoredCRC [15:0]	Read & Write	Computed
	1	StoredPC [15:0]	Read & Write	Computed / NVM EPC
	2	EPC [127:112]	Read & Write	NVM EPC
	3	EPC [111:96]		
	4	EPC [95:80]		
	5	EPC [79:64]		
	6	EPC [63:48]		
	7	EPC [47:32]		
	8	EPC [31:16]		
	9	EPC [15:0]		
	10 to 32	Unused address space	None	N/A
33	XPC_W1 [15:0] (see table below)	Read & Write	Computed / NVM EPC	
10 ₂ : TID	0	TID [95:80]	Read Only	ROM / NVM EPC
	1	TID [79:64]		
	2	TID [63:48]		
	3	TID [47:32]		
	4	TID [31:16]		
	5	TID [15:0]		
11 ₂ : USER (File_0)	0	USER [159:144]	Read & Write	NVM EPC
	1	USER [143:128]		
	2	USER [127:112]		
	3	USER [111:96]		
	4	USER [95:80]		
	5	USER [79:64]		
	6	USER [63:48]		
	7	USER [47:32]		
	8	USER [31:16]		
	9	USER [15:0]		
	10 to 31	Unused address space	None	N/A
	32 to 255	NFC memory mapping (see table below)	see below	NVM NFC

The EPC interface access to User Memory Bank words 32 to 255 (NFC mapped memory) is controlled first by the EPC password protection and locks used for the User Memory Bank and subsequently by the NFC sharing read/write lock bytes unless stated otherwise in this document.

The EPC interface has read/write access to the to NFC mapped memory but only as permitted by the NFC sharing read/write lock bytes.

The EPC interface applies the untraceably hidden memory conditions to NFC mapped memory when the User Memory Bank is hidden.

**7.3. EPC GEN2 V2 - LARGE EPC MEMORY MAP**

Memory Bank	Word Address (decimal)	Content	Access Type (unless password protected or locked)	Memory Type
00 ₂ : RESERVED	0	Kill Password [31:16]	Read & Write	NVM EPC
	1	Kill Password [15:0]		
	2	Access Password [31:16]		
	3	Access Password [15:0]		
01 ₂ : EPC	0	StoredCRC [15:0]	Read & Write	Computed
	1	StoredPC [15:0]	Read & Write	Computed / NVM EPC
	2	EPC [223:208]	Read & Write	NVM EPC
	3	EPC [207:192]		
	4	EPC [191:176]		
	5	EPC [175:160]		
	6	EPC [159:144]		
	7	EPC [143:128]		
	8	EPC [127:112]		
	9	EPC [111:96]		
	10	EPC [95:80]		
	11	EPC [79:64]		
	12	EPC [63:48]		
	13	EPC [47:32]		
	14	EPC [31:16]		
	15	EPC [15:0]		
	16 to 32	Unused address space	None	N/A
33	XPC_W1 [15:0] (see table below)	Read & Write	Computed / NVM EPC	
10 ₂ : TID	0	TID [95:80]	Read Only	ROM / NVM EPC
	1	TID [79:64]		
	2	TID [63:48]		
	3	TID [47:32]		
	4	TID [31:16]		
	5	TID [15:0]		
11 ₂ : USER (File_0)	0	USER [63:48]	Read & Write	NVM EPC
	1	USER [47:32]		
	2	USER [31:16]		
	3	USER [15:0]		
	4 to 31	Unused address space	None	N/A
	32 to 255	NFC memory mapping (see table below)	see below	NVM NFC

The EPC interface access to User Memory Bank words 32 to 255 (NFC mapped memory) is controlled first by the EPC password protection and locks used for the User Memory Bank and subsequently by the NFC sharing read/write lock bytes unless stated otherwise in this document.

The EPC interface has read/write access to the to NFC mapped memory but only as permitted by the NFC sharing read/write lock bytes.

The EPC interface applies the untraceably hidden memory conditions to NFC mapped memory when the User Memory Bank is hidden.



The following table gives more details about the TID memory bank:

TID memory bank

Memory Bank	Word Address (decimal)	M S B														L S B	Memory Type	
		0	1	2	3	4	5	6	7	8	9	A	B	C	D			E
10z: TID	0	Allocation Class (E2h)							Tag MDID MSB's (80h)							ROM		
		1	1	1	1	0	0	0	1	0	1	0	0	0	0		0	0
	1	Tag MDID LSB's (Bh)			Tag Model Number											ROM		
		1	0	1	1	0	0	0	0	1	0	1	0	0	0		0	0
	2	XTID																ROM
		0	0	1	0	0	0	0	0	0	0	0	0	0	0	0	0	
	3	IC Serial Number [47:32]																NVM/ROM
		Customer number (all zeroes reserved for EM)										1	0	0	1	0	0	
	4	IC Serial Number [31:16] (same as in NFC UID)																NVM EPC
	5	IC Serial Number [15:0] (same as in NFC UID)																NVM EPC

Note 1: EPC size, where 0 indicates small EPC memory and 1 indicates large EPC memory

7.5. EPC GEN2 V2 DELIVERY STATE

EPC Gen2 V2 delivery state has the following default product configuration:

Access Password and Kill Password are readable/writeable with a value 0000'0000'0000'0000h

Unique Identification number (UID / TID) is programmed and write-permalocked

A default 96-bit EPC Code value is 0000'0000'0000'0024'nnnn'nnnnh where nnnn'nnnh are the 32 LSB's of serial number found also in the TID memory (EPC memory is unlocked).

8. EPC GEN2 V2 COMMANDS

The table below shows all implemented commands in em|echo. For the description of all mandatory and optional commands, please refer to the EPCglobal Gen2 V2 standard. All mandatory commands of the EPCglobal Gen2 V2 standard are implemented.

Command	Command Code	Command Type	Comment
QueryRep	'00'	Mandatory	
ACK	'01'	Mandatory	
Query	'1000'	Mandatory	
QueryAdjust	'1001'	Mandatory	
Select	'1010'	Mandatory	Memory matching on NFC memory is not supported and results in a not-matching condition.
NAK	'11000000'	Mandatory	
Req_RN	'11000001'	Mandatory	
Read	'11000010'	Mandatory	
Write	'11000011'	Mandatory	
Kill	'11000100'	Mandatory	Failed Kill command sequence results in security timeout
Lock	'11000101'	Mandatory	
Access	'11000110'	Optional ¹⁾	Failed Access command sequence results in security timeout
BlockWrite	11000111'	Optional	Supports writing one or two 16-bits words. The address must start on an even word number if two words are to be written.
BlockPermalock	'11001001'	Optional	USER memory block size is two words.
Untraceable	'1110001000000000'	Optional ¹⁾	See EPC Privacy Features below.

Note 1: This command is normally optional but is mandatory for Alteration EAS and Tag Alteration (Core) compliance.



8.1. WRITE OPERATIONS USING THE TAG NOTIFICATION (TN) INDICATOR

TN is a vendor defined indicator bit that is part of the XPC_W1 word that is reported to a reader as part of the reply to an ACK command. If the XPC_W1 indicator (XI) = 1 in the PC Word then TN is reported as part of the XPC_W1 word. If XI = 0 in the PC Word then TN is reported as part of the PC Word. em|echo uses TN to indicate the power level seen during inventory. TN = 1 indicates the power level is sufficient to perform NVM NFC write operation which by default means the power level is also sufficient to perform a NVM EPC write operation. TN = 0 indicates the power level is insufficient to perform a NVM NFC operation but it may be sufficient to perform a NVM EPC write operation. A reader can attempt any supported command that performs a NVM write operation regardless of the TN value.

There are three scenarios for using TN:

1. em|echo reports TN = 0 during inventory. If the reader proceeds to use an access command that writes to memory then the tag will check the appropriate power level based on the NVM memory to be written. This provides the maximum write sensitivity for the tag at the cost of a slightly longer write time to perform the power check.
2. em|echo reports TN = 1 during inventory. If the reader proceeds to use an access command that writes to memory then the tag does not check the appropriate level based on the NVM to be written. This provides the fastest write time for the tag at the cost of slightly degraded write sensitivity for NVM EPC write operations.
3. If a reader uses a Select command on TN = 1 in the XPC_W1 word then only tags with sufficient power for NVM will be selected for inventory. If the reader proceeds to use an access command that writes to memory then the tag will check the appropriate power level based on the NVM memory to be written.

8.2. EPC PRIVACY FEATURES

Support for EPC privacy is provided using the *Untraceable* command and it only applies to the EPC interface. The *Untraceable* command may only be used by an Interrogator that asserts the Untraceable privilege. An Interrogator must use a non-zero Access password to enter the Secured state in order to assert that it has the Untraceable privilege.

The *Untraceable* command allows an Interrogator to instruct the em|echo to (a) alter the **L** and **U** bits in EPC memory, (b) hide memory from Interrogators with a deasserted Untraceable privilege, and/or (c) reduce its operating range for all Interrogators. The memory that a Tag may hide includes words of EPC memory, the Tag serialization in TID memory, all of TID memory, and/or User memory. Note that the NFC memory is mapped into the the EPC User memory space and therefore NFC memory is hidden from the EPC interface when User memory is hidden. Untraceable and traceable Tags behave identically from a state-machine and command-response perspective; the difference between them is (a) the memory the Tag exposes to an Interrogator with a deasserted Untraceable privilege and/or (b) the Tag's operating range.

The *Untraceable* command may be used to change the operational read range of a device. em|echo supports this feature in a manner that permits having either full read range (normal operation) or no read range (deactivated operation). A deactivated device always remains in the Ready state and will not participate in any inventory operations.

The Range parameter in the *Untraceable* command is used to specify the persistent operational read range of the device. If Range = 00₂ then the device persistently enables normal operation. If Range = 10₂ then the device persistently enables deactivation and the device becomes deactivated immediately upon reply to the *Untraceable* command. If Range = 01₂ then it has no effect on the device.

A deactivated device may be temporarily reactivated (normal operation) by any Interrogator using a *Select* command with any of the assigned EM Microelectronic Mask Designer ID's (MDID's). The *Select* command parameters are MemBank = 10₂, Pointer = 08h, Length = 0Ch, and matching Mask = 00Bh or = 40Bh or = 80Bh or = C0Bh. When a device is temporarily reactivated, it remains in the normal operational mode until the device loses power.

The NFC interface may also be used to enable/disable the EPC privacy features via the Gen2V2conf word, the StoredCRC + StoredPC word, and the IC Configuration 3 word.

9. PAD LOCATION DIAGRAM

All dimensions in μm .

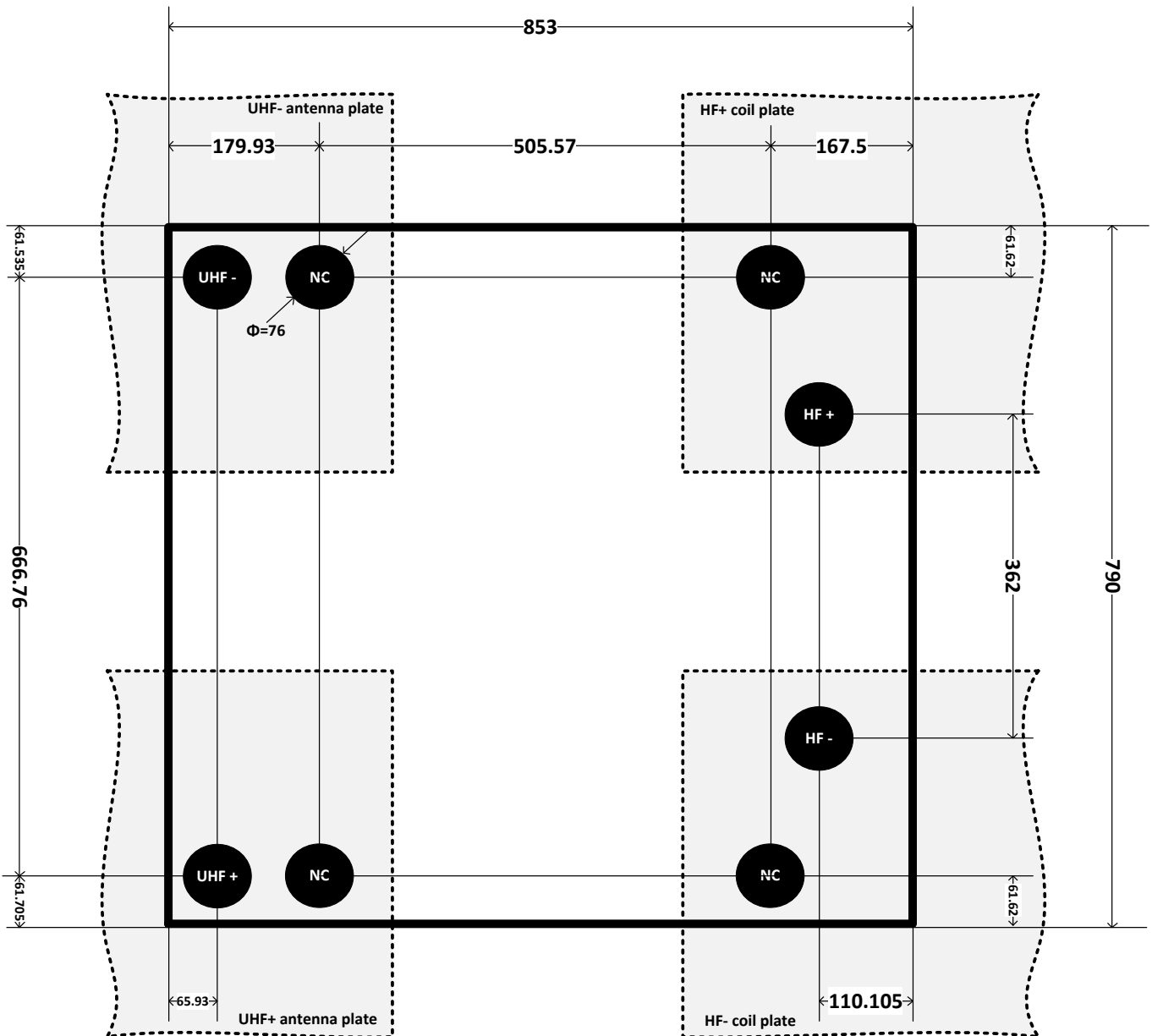

The chip size is calculated including the scribe line. UHF antenna plates and HF coil plates are added here only to illustrate inlay assembly option.

9.1. PIN DESCRIPTION

Pin	Name	Type	Description
1	HF+	coil	coil terminal for HF +
2	HF-	coil	coil terminal for HF -
3	NC	NC	
4	NC	NC	
5	UHF+	RF	antenna terminal for UHF
6	UHF-	RF	antenna terminal for UHF
7	NC	NC	
8	NC	NC	

NC: Not connected



10. ORDERING INFORMATION

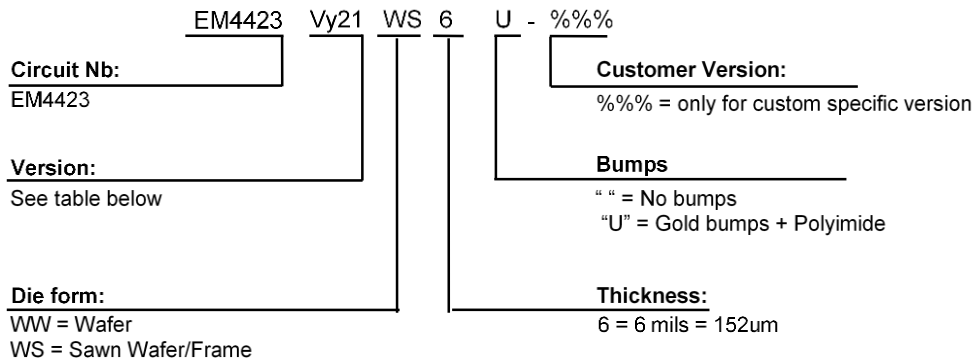

10.1. VERSIONS

Versions are identified as "EM4423Vx21" where x is variables that are defined in the following table.

x	EPC Memory Format
1	Small EPC
2	Large EPC

10.2. STANDARD VERSIONS AND SAMPLES

The versions below are considered standard and should be readily available. For other delivery form, please contact EM Microelectronic-Marín S.A. For samples, please order exclusively from the standard versions.

Part Number	EPC Memory Format	Package / Die Form	Delivery Form
EM4423V121WS6U	Small EPC	Sawn wafer / Gold bumped +PI – thickness of 6 mils	Wafer on frame
EM4423V221WS6U	Large EPC	Sawn wafer / Gold bumped +PI – thickness of 6 mils	Wafer on frame



11. PRODUCT SUPPORT

Check our website at www.emmicroelectronic.com under Products/RF Identification section. Questions can be submitted to rfidsupport@emmicroelectronic.com.

EM Microelectronic-Marín SA ("EM") makes no warranties for the use of EM products, other than those expressly contained in EM's applicable General Terms of Sale, located at <http://www.emmicroelectronic.com>. EM assumes no responsibility for any errors which may have crept into this document, reserves the right to change devices or specifications detailed herein at any time without notice, and does not make any commitment to update the information contained herein.

No licenses to patents or other intellectual property rights of EM are granted in connection with the sale of EM products, neither expressly nor implicitly.

In respect of the intended use of EM products by customer, customer is solely responsible for observing existing patents and other intellectual property rights of third parties and for obtaining, as the case may be, the necessary licenses. This specific RFID product is manufactured under one or more licenses, which contain certain exclusions. This product may not be sold, used, leased, offered for sale, or otherwise transferred, exported, and imported in the Transportation Market. "Transportation Market" means (i) Electronic Toll and Traffic Management (ETTM), (ii) Public Sector Vehicle Registration, Inspection and Licensing Programs, (iii) Railroad Locomotive and Wagon Tracking, (iv) airport based ground transportation management systems (GTMS) and taxi dispatch, (v) revenue based parking, and (vi) vehicle initiated mobile payment applications, where the RFID sticker/tag is initially attached to the vehicle but not incorporated at the point of vehicle manufacture.

Important note: The use of EM products as components in medical devices and/or medical applications, including but not limited to, safety and life supporting systems, where malfunction of such EM products might result in damage to and/or injury or death of persons is expressly prohibited, as EM products are neither destined nor qualified for use as components in such medical devices and/or medical applications. The prohibited use of EM products in such medical devices and/or medical applications is exclusively at the risk of the customer.